



Bonfiglioli

Riduttori

A series

Riduttori ad assi ortogonali

Helical bevel gear units

Kegelradgetrieben

Réducteurs avec arbres orthogonaux

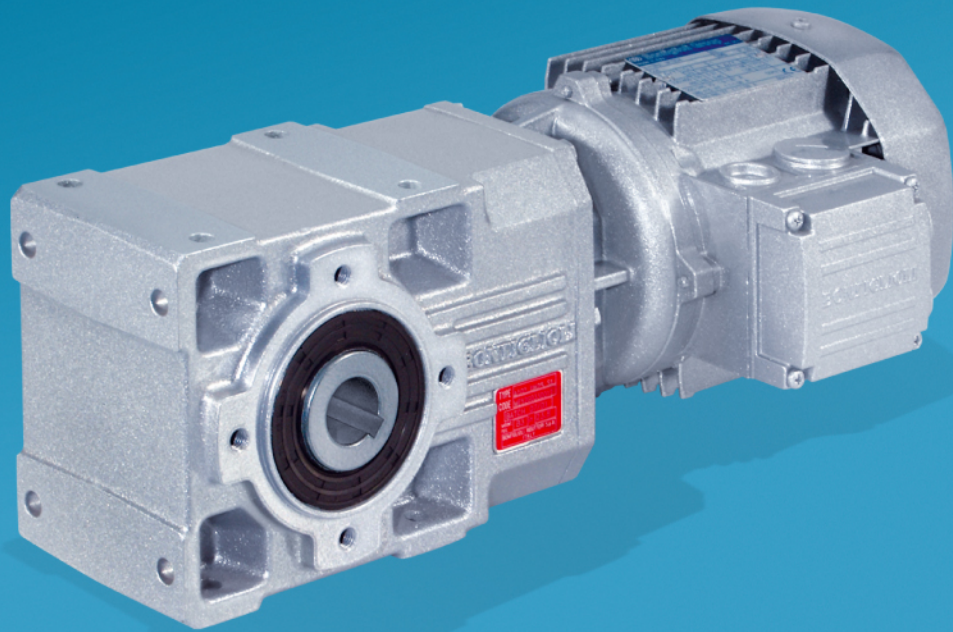



INFORMAZIONI GENERALI
GENERAL INFORMATION
ALLGEMEINE INFORMATIONEN
INFORMATIONS GENERALES

Paragrafo
Chapter
Abschnitt
Paragraphe

Pagina
Page
Seite
Page

	Descrizione	Description	Beschreibung	Description	
1	Simbologia e unità di misura	<i>Symbols and units of measure</i>	Symbole und Maßeinheiten	<i>Symboles et unités de mesure</i>	2
2	Coppia	<i>Torque</i>	Abtriebsmoment	<i>Couple</i>	4
3	Potenza	<i>Power</i>	Leistung	<i>Puissance</i>	4
4	Potenza termica	<i>Thermal capacity</i>	Termische Grenzleistung	<i>Puissance thermique</i>	5
5	Rendimento	<i>Efficiency</i>	Wirkungsgrad	<i>Rendement</i>	6
6	Rapporto di riduzione	<i>Gear ratio</i>	Getriebeübersetzung	<i>Rapport de réduction</i>	6
7	Velocità angolare	<i>Angular velocity</i>	Drehzahl	<i>Vitesse angulaire</i>	7
8	Momento d'inerzia	<i>Moment of inertia</i>	Trägheitsmoment	<i>Moment d'inertie</i>	7
9	Fattore di servizio	<i>Service factor</i>	Betriebsfaktor	<i>Facteur de service</i>	8
10	Manutenzione	<i>Maintenance</i>	Wartung	<i>Entretien</i>	9
11	Selezione	<i>Selection</i>	Antriebsauswahl	<i>Sélection</i>	10
12	Verifiche	<i>Verification</i>	Prüfungen	<i>Vérifications</i>	13
13	Installazione	<i>Installation</i>	Installation	<i>Installation</i>	15
14	Istruzioni di installazione	<i>Installation instructions</i>	Anbauanweisungen	<i>Instructions pour l'installation</i>	17
15	Istruzioni per il serraggio del calettatore	<i>Instructions for fitting of shrink disc</i>	Anleitungen für den anzug der schrumpfscheibe	<i>Instructions pour le blocage de la frette de serrage</i>	18
16	Istruzioni per montaggio boccole di adattamento - QF	<i>Mounting instructions for adapter bushings - QF</i>	Montageanleitung für Adapterbuchsen - QF	<i>Instructions pour le montage des douilles d'adaptation - QF</i>	19
17	Stoccaggio	<i>Storage</i>	Lagerung	<i>Stockage</i>	21
18	Condizioni di fornitura	<i>Conditions of supply</i>	Lieferbedingungen	<i>Conditions de livraison</i>	21
19	Specifiche della vernice	<i>Paint specifications</i>	Angaben zu den Antrichstoffe	<i>Spécifications de la peinture</i>	21

RIDUTTORI AD ASSI ORTOGONALI SERIE A
HELICAL BEVEL GEAR UNITS SERIES A
KEGELRADGETRIEBE SERIE A
REDUCTEURS AVEC ARBRES ORTHOGONAUX SERIE A

20	Caratteristiche costruttive	<i>Design features</i>	Konstruktive Eigenschaften	<i>Caractéristiques de construction</i>	22
21	Forme costruttive	<i>Versions</i>	Bauformen	<i>Formes de construction</i>	23
22	Designazione	<i>Designation</i>	Bezeichnung	<i>Désignation</i>	24
23	Lubrificazione	<i>Lubrication</i>	Schmierung	<i>Lubrification</i>	29
24	Posizioni di montaggio e orientamento morsetteria	<i>Mounting position and terminal box angular position</i>	Einbaulagen und lage des klemmenkastens	<i>Positions de montage et orientation boîte a borne</i>	31
25	Carichi radiali	<i>Overhung loads</i>	Radialkräfte	<i>Charges radiales</i>	38
26	Carichi assiali	<i>Thrust loads</i>	Axialkräfte	<i>Charges axiales</i>	41
27	Rotazione alberi	<i>Shafts arrangement</i>	Wellendrehung	<i>Rotation arbres</i>	41
28	Dispositivo antiretro	<i>Anti-run back device</i>	Rücklaufsperr	<i>Dispositif anti-retour</i>	42
29	Dati tecnici motoriduttori	<i>Gearmotor rating charts</i>	Getriebemotoreauswahltabellen	<i>Données techniques motoréducteurs</i>	43
30	Dati tecnici riduttori	<i>Gearbox rating charts</i>	Getriebe auswahltabellen	<i>Données techniques réducteurs</i>	76
31	Predisposizioni motore	<i>Motor availability</i>	Baumöglichkeiten	<i>Prédispositions moteurs</i>	98
32	Momento d'inerzia	<i>Moment of inertia</i>	Trägheitsmoment	<i>Moment d'inertie</i>	101
33	Rapporti esatti	<i>Exact ratios</i>	Exakte übersetzung	<i>Rapports exacts</i>	113
34	Dimensioni	<i>Dimensions</i>	Abmessungen	<i>Dimensions</i>	115
35	Accessori	<i>Accessories</i>	Zubehör	<i>Accessoires</i>	159
36	Albero macchina	<i>Customer' shaft</i>	Maschinachse	<i>Arbre machine</i>	161

MOTORI ELETTRICI
ELECTRIC MOTORS
ELEKTROMOTOREN
MOTEURS ELECTRIQUES

M1	Simbologia e unità di misura	<i>Symbols and units of measurement</i>	Symbole und Maßeinheiten	<i>Symboles et unités de mesure</i>	164
M2	Caratteristiche generali	<i>General characteristics</i>	Allgemeine Eigenschaften	<i>Caractéristiques générales</i>	165
M3	Caratteristiche meccaniche	<i>Mechanical features</i>	Mechanische Eigenschaften	<i>Caractéristiques mécaniques</i>	168
M4	Caratteristiche elettriche	<i>Electrical characteristics</i>	Elektrische Eigenschaften	<i>Caractéristiques électriques</i>	173
M5	Motori asincroni autofrenanti	<i>Asynchronous brake motors</i>	Drehstrombremsmotoren	<i>Moteurs frein asynchrones</i>	180
M6	Motori autofrenanti in c.c., tipo BN_FD	<i>DC brake motors type BN_FD</i>	Drehstrombremsmotoren mit Gleichstrombremse: typ BN_FD	<i>Moteurs frein en c.c. type BN_FD</i>	181
M7	Motori autofrenanti in c.a., tipo BN_FA	<i>AC brake motors type BN_FA</i>	Wechselstrombremsmotoren: typ BN_FA	<i>Moteurs frein en c.a. type BN_FA</i>	186
M8	Motori autofrenanti in c.a., tipo BN_BA	<i>AC brake motors type BN_BA</i>	Drehstrom-Bremsmotoren mit Wechselstrombremse: typ BN_BA	<i>Moteurs frein en c.a. type BN_BA</i>	190
M9	Sistemi di sblocco freno	<i>Brake release systems</i>	Brenslüfthebel	<i>Systemes de déblocage frein</i>	194
M10	Opzioni	<i>Options</i>	Optionen	<i>Options</i>	196
M11	Dati tecnici motori	<i>Motor rating charts</i>	Motoreauswahl tabellen	<i>Données techniques des moteurs</i>	203
M12	Dimensioni motori	<i>Motors dimensions</i>	Motorenabmessungen	<i>Dimensions moteurs</i>	219

Revisions
L'indice di revisione del catalogo è riportato a pag. 232.
Al sito www.bonfiglioli.com sono disponibili i cataloghi con le revisioni aggiornate.

Revisions
Refer to page 232 for the catalog revision index.
Visit www.bonfiglioli.com to search for catalogues with up-to-date revisions.

Änderungen
Das Revisionsverzeichnis des Katalogs wird auf Seite 232 wiedergegeben.
Auf unserer Website www.bonfiglioli.com werden die Kataloge in ihrer letzten, überarbeiteten Version angeboten.

Révisions
Le sommaire de révision du catalogue est indiqué à la page 232.
Sur le site www.bonfiglioli.com des catalogues avec les dernières révisions sont disponibles.

**1 - SIMBOLOGIA E UNITÀ
DI MISURA**
**1 - SYMBOLS AND UNITS
OF MEASURE**
**1 - SYMBOLE UND
MAßEINHEITEN**
**1 - SYMBOLES ET UNITES
DE MESURE**

Simb. Symb.	U.m. Meßeinh.	Descrizione	Description	Beschreibung	Description
A_{N 1, 2}	[N]	Carico assiale nominale	<i>Permissible axial force</i>	Nenn-Axialbelastung	<i>Charge axiale nominale</i>
f_s	–	Fattore di servizio	<i>Service factor</i>	Betriebsfaktor	<i>Facteur de service</i>
f_T	–	Fattore termico	<i>Thermal factor</i>	Temperaturfaktor	<i>Facteur thermique</i>
f_{TP}	–	Fattore di temperatura	<i>Temperature factor</i>	Wärmefaktor	<i>Facteur de température</i>
i	–	Rapporto di trasmissione	<i>Gear ratio</i>	Übersetzung	<i>Rapport de réduction</i>
I	–	Rapporto di intermittenza	<i>Cyclic duration factor</i>	Relative Einschaltdauer	<i>Rapport d'intermittence</i>
J_C	[Kgm ²]	Momento di inerzia carico	<i>Mass moment of inertia to be driven</i>	Massenträgheitsmoment der externen Massen	<i>Moment d'inertie de la charge</i>
J_M	[Kgm ²]	Momento di inerzia motore	<i>Motor mass moment of inertia</i>	Motorträgheitsmoment	<i>Moment d'inertie du moteur</i>
J_R	[Kgm ²]	Momento di inerzia riduttore	<i>Mass moment of inertia for the gear unit</i>	Getriebeträgheitsmoment	<i>Moment d'inertie du réducteur</i>
K	–	Fattore di accelerazione delle masse	<i>Mass acceleration factor</i>	Massenbeschleunigungsfaktor	<i>Facteur d'accélération des masses</i>
K_r	–	Costante di trasmissione	<i>Transmission element factor</i>	Belastungsfaktor der Radiallast	<i>Constante de transmission</i>
M_{1, 2}	[Nm]	Coppia	<i>Torque</i>	Drehmoment	<i>Couple</i>
M_{c 1, 2}	[Nm]	Coppia di calcolo	<i>Calculated torque</i>	Berechnetes Drehmoment	<i>Couple de calcul</i>
M_{n 1, 2}	[Nm]	Coppia nominale	<i>Rated torque</i>	Nennmoment	<i>Couple nominal</i>
M_{r 1, 2}	[Nm]	Coppia richiesta	<i>Torque demand</i>	Benötigtes Drehmoment	<i>Couple nécessaire</i>
n_{1, 2}	[min ⁻¹]	Velocità	<i>Speed</i>	Abtriebsdrehzahl	<i>Vitesse</i>
P_{1, 2}	[kW]	Potenza	<i>Power</i>	Leistung	<i>Puissance</i>
P_{N 1, 2}	[kW]	Potenza nominale	<i>Rated power</i>	Nennleistung	<i>Puissance nominale</i>
P_{R 1, 2}	[kW]	Potenza richiesta	<i>Power demand</i>	Benötigte Leistung	<i>Puissance nécessaire</i>
R_{C 1, 2}	[N]	Carico radiale di calcolo	<i>Calculated radial force</i>	Berechnete Axialbelastung	<i>Charge radiale de calcul</i>
R_{N 1, 2}	[N]	Carico radiale nominale	<i>Permissible overhung load</i>	Zulässige Radialbelastung	<i>Charge radiale nominale</i>
S	–	Fattore di sicurezza	<i>Safety factor</i>	Sicherheitsfaktor	<i>Facteur de sécurité</i>
t_a	[°C]	Temperatura ambiente	<i>Ambient temperature</i>	Umgebungstemperatur	<i>Température ambiante</i>
t_f	[min]	Tempo di funzionamento a carico costante	<i>Work time under constant load</i>	Betriebszeit während nennbetrieb	<i>Temps de fonctionnement à charge constante</i>
t_r	[min]	Tempo di riposo	<i>Rest time</i>	Stillstandszeit	<i>Temps de repos</i>
η_d	–	Rendimento dinamico	<i>Dynamic efficiency</i>	Dynamischer Wirkungsgrad	<i>Rendement dynamique</i>
η_s	–	Rendimento statico	<i>Static efficiency</i>	Statischer Wirkungsgrad	<i>Rendement statique</i>

1 valore riferito all'albero veloce

1 value applies to input shaft

1 Werte beziehen sich auf die Antriebswelle

1 valeurs pour l'arbre rapide

2 valore riferito all'albero lento

2 value applies to output shaft

2 Werte beziehen sich auf die Abtriebswelle

2 valeurs pour l'arbre lent



Questo simbolo riporta i riferimenti angolari per l'indicazione della direzione del carico radiale (l'albero è visto di fronte).

This symbol refers to the angle the overhung load applies (viewing from drive end).

Dieses Symbol gibt die Winkelbezugswerte für die Angabe der Richtung der Radialkräfte an (Stirnansicht der Welle).

Ce symbole présente les références angulaires pour l'indication de la direction de la charge radiale (l'arbre est vu de face).



Simbolo riferito al peso dei riduttori e dei motoriduttori.
I valori riportati nelle tabelle dei motoriduttori sono comprensivi sia del peso del motore a 4 poli sia del peso del lubrificante contenuto, qualora previsto da BONFIGLIOLI RIDUTTORI.

*Symbol refers to weight of gearmotors and speed reducers.
Figure for gearmotors incorporates the weight of the 4-pole motor and for life lubricated units, where applicable, the weight of the oil.*

Symbol für das Gewicht der Getriebe und der Getriebemotoren.
Die in der Getriebemotoren-Tabelle genannten Werte schließen das Gewicht des vierpoligen Motors und die eingefüllte Schmierstoffmenge ein, sofern von BONFIGLIOLI RIDUTTORI vorgesehen.

*Symbole se référant aux poids des réducteurs et des motoréducteurs.
Les valeurs indiquées dans les tableaux des motoréducteurs comprennent tant le poids du moteur à 4 pôles que le poids du lubrifiant contenu, lorsque prévu par BONFIGLIOLI RIDUTTORI.*

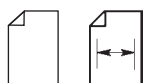

Il simbolo identifica la pagina alla quale può essere reperita l'informazione.

The symbol shows the page the information can be sorted from.

Das Symbol Kennzeichnet die Seite, auf die die Information gefunden werden kann.

Le symbole idendifie la page à laquelle l'on peut trouver l'information.



Motoriduttore con motore integrato.

Gearmotor with compact motor.

Getriebemotor mit Kompaktmotor.

Motoréducteur avec moteur compact.



Motoriduttore abbinato con motore a standard IEC.

Gearmotor with IEC motor.

Getriebemotor mit IEC-Motor.

Motoréducteur avec moteur normalisé IEC.



Riduttore predisposto per abbinamento con motore a standard IEC.

Gear unit with IEC motor interface.

Getriebe vorbereitet für IEC-motor.

Réducteur prédisposé pour liaison a moteur IEC.



Riduttore predisposto per accoppiamento a servomotore.

Gear unit with servomotor input adapter.

Getriebe vorbereitet für Servomotor.

Réducteur prédisposé pour liaison a servomoteur.



Riduttore dotato di albero veloce cilindrico.

Speed reducer with solid input shaft.

Getriebe mit cylindrischer Antriebswelle.

Réducteur avec arbre rapide Cylindrique.

**INFORMAZIONI GENERALI****GENERAL INFORMATION****ALLGEMEINEINFORMATIONEN****INFORMATIONS GENERALES****2 - COPPIA****Coppia nominale**
M_{n2} [Nm]

È la coppia trasmissibile in uscita con carico continuo uniforme, riferita alla velocità in ingresso n₁ e a quella corrispondente in uscita n₂.
È calcolata in base ad un fattore di servizio f_s = 1.

2 - TORQUE**Rated torque**
M_{n2} [Nm]

The torque that can be transmitted continuously through the output shaft, with the gear unit operated under a service factor f_s = 1.
Rating is speed sensitive.

2 - ABTRIEBSMOMENT**Nenn-Drehmoment**
M_{n2} [Nm]

Dies ist das an der Abtriebswelle übertragbare Drehmoment bei gleichförmiger Dauerbelastung bezogen auf die Antriebsdrehzahl n₁ und die entsprechende Abtriebsdrehzahl n₂.
Das Drehmoment wird auf Grundlage eines Betriebsfaktor f_s = 1 berechnet.

2 - COUPLE**Couple nominal**
M_{n2} [Nm]

C'est le couple transmissible en sortie avec une charge continue uniforme se référant à la vitesse en entrée n₁ et à celle correspondante en sortie n₂.
Il est calculé sur la base d'un facteur de service f_s = 1.

Coppia richiesta
M_{r2} [Nm]

Rappresenta la coppia richiesta dall'applicazione e dovrà sempre essere uguale o inferiore alla coppia in uscita nominale M_{n2} del riduttore scelto.

Required torque
M_{r2} [Nm]

The torque demand based on application requirement. It must always be equal to or less than torque M_{n2} the gearbox under study is rated for.

Verlangtes Drehmoment
M_{r2} [Nm]

Dies ist das von der Anwendung verlangte Drehmoment, das stets kleiner oder gleich dem Nenn-Abtriebsmoment M_{n2} des gewählten Getriebes sein muß.

Couple requis
M_{r2} [Nm]

Il représente le couple requis par l'application et devra toujours être inférieur ou égal au couple en sortie nominal M_{n2} du réducteur choisi.

Coppia di calcolo
M_{c2} [Nm]

È il valore di coppia da utilizzare per la selezione del riduttore considerando la coppia richiesta M_{r2} e il fattore di servizio f_s ed è dato dalla formula:

Calculated torque
M_{c2} [Nm]

Computational torque value to be used when selecting the gearbox. It is calculated considering the required torque M_{r2} and service factor f_s, as per the equation here after:

Soll-Drehmoment
M_{c2} [Nm]

Dies ist das bei der Wahl des Getriebes zugrundezulegende Drehmoment, wobei das übertragene Drehmoment M_{r2} und der Betriebsfaktor f_s zu berücksichtigen sind; das Soll-Drehmoment wird mit folgender Gleichung berechnet:

Couple de calcul
M_{c2} [Nm]

C'est la valeur de couple à utiliser pour la sélection du réducteur en considérant le couple requis M_{r2} et le facteur de service f_s et s'obtient avec la formule :

$$M_{c2} = M_{r2} \cdot f_s < M_{n2} \quad (1)$$

3 - POTENZA**Potenza nominale in entrata**
P_{n1} [kW]

Nelle tabelle di selezione dei riduttori è la potenza applicabile in entrata riferita alla velocità n₁, considerando un fattore di servizio f_s = 1.

3 - POWER**Rated power**
P_{n1} [kW]

In the gearbox selection charts this is the power applicable to input shaft, based on input speed n₁ and corresponding to service factor f_s = 1.

3 - LEISTUNG**Leistung Antriebswelle**
P_{n1} [kW]

In den Tabellen für die Wahl der Getriebe ist die an der Antriebswelle übertragbare Leistung auf die Drehzahl n₁ bezogen und es wurde ein Betriebsfaktor f_s = 1 angenommen.

3 - PUISSANCE**Puissance en entrée**
P_{n1} [kW]

Dans les tableaux de sélection des réducteurs, c'est la puissance applicable en entrée se rapportant à la vitesse n₁ et en considérant un facteur de service f_s = 1.



4 - POTENZA TERMICA
 P_t [kW]

P_t è il valore che indica il limite termico del riduttore e rappresenta la potenza trasmissibile in servizio continuo, e alla temperatura ambiente $t_a = 20^\circ\text{C}$, senza che si producano danneggiamenti negli organi del riduttore o degradamenti del lubrificante. Vedi tab. (A1).

Nel caso di servizio intermittente, o di temperatura ambiente diversa da 20°C , il valore di P_t deve essere corretto per mezzo del fattore f_t , espresso dalla tabella (A2), ossia $P_t' = P_t \times f_t$

Infine, per riduttori con più di due riduzioni e/o con rapporto $i > 45$ la verifica della potenza termica non è necessaria in quanto quest'ultima è certamente superiore alla potenza meccanica trasmissibile.

4 - THERMAL CAPACITY
 P_t [kW]

P_t is the power that can be transmitted through the gear unit, under a continuous duty and an ambient temperature of 20°C , without resulting into damage of the inner parts or degradation of the lubricant properties. Refer to chart (A1) for specific kW ratings.

In case of intermittent duty, or an operating ambient temperature other than the rated 20°C , the P_t value should be adjusted through the factor f_t , obtained from chart (A2), as per the following equation: $P_t' = P_t \times f_t$

Gear units featuring more than 2 reductions and/or a gear ratio greater than $i = 45$ do not normally require the thermal limit to be checked as in these cases the thermal rating usually exceeds the mechanical rating.

4 - THERMISCHE GRENZLEISTUNG
 P_t [kW]

P_t steht für den Wert der Wärmegrenzleistung des Getriebes und gibt die im Dauerbetrieb und bei einer Umgebungstemperatur $t_a = 20^\circ\text{C}$ übertragbare Leistung an, ohne daß sich daraus Schäden an den Getriebeorganen oder ein Verfall des Schmiermittels ergeben. Siehe Tab. (A1). Bei einem Aussetzbetrieb oder bei verschiedener Umgebungstemperatur als 20°C muß der Wert P_t über den Faktor f_t korrigiert werden, der in der Tabelle (A2) aufgeführt wird bzw. $P_t' = P_t \times f_t$

Bei Getrieben mit mehr als zwei Untersetzungsstufen und/oder einem Verhältnis von $i > 45$ ist die Kontrolle der thermischen Leistung nicht erforderlich, da sie sicher oben der mechanisch übertragbaren Leistung liegt.

4 - PUISSANCE THERMIQUE
 P_t [kW]

P_t est la valeur qui indique la limite thermique du réducteur et représente la puissance transmissible en service continu, et à une température ambiante $t_a = 20^\circ\text{C}$, sans apparition de dommages au niveau des organes du réducteur ou de dégradations du lubrifiant. Voir tab. (A1).

En cas de service intermittent ou de température ambiante différente de 20°C , la valeur de P_t doit être corrigée au moyen du facteur f_t , exprimé dans le tableau (A2), à savoir: $P_t' = P_t \times f_t$

Enfin, pour les réducteurs ayant plus de deux réductions et/ou un rapport $i > 45$, la vérification de la puissance thermique n'est pas nécessaire car elle est certainement supérieure à la puissance mécanique transmissible.

(A1)

P_t [kW] 20°C		
	$n_1 = 1400 \text{ min}^{-1}$	$n_1 = 2800 \text{ min}^{-1}$
A 05 2	3.2	2.4
A 10 2	4.8	4.0
A 20 2	6.0	5.4
A 30 2	8.0	6.6
A 35 2	9.5	8.2
A 41 2	11.5	9.6
A 50 2	20	18.0
A 55 2	21	18.0
A 60 2	27	23
A 70 3	31	26
A 80 3	44	39
A 90 3	64	57

(A2)

f_t					
t_a [$^\circ\text{C}$]	Servizio continuo Continuous duty Dauerbetrieb Service continu	Servizio intermittente / Intermittent duty / Aussetzbetrieb / Service intermittent			
		Grado di intermittenza / Degree of intermittence / Relative Einschaltdauer / Degrè d'intermittence			
		[1]			
		80%	60%	40%	20%
40	0.80	1.1	1.3	1.5	1.6
30	0.85	1.3	1.5	1.6	1.8
20	1.0	1.5	1.6	1.8	2.0
10	1.15	1.6	1.8	2.0	2.3



Il grado di intermittenza (I)% è dato dal rapporto fra il tempo di funzionamento a carico t_f e il tempo totale ($t_f + t_r$), espresso in percentuale.

Where cyclic duration factor (I)% is the relationship of operating time under load t_f to total time ($t_f + t_r$) expressed as a percentage.

Wobei die Einschaltdauer (I)% von dem Verhältnis zwischen Betriebszeit unter Last t_f und der Gesamtbetriebszeit ($t_f + t_r$), ausgedrückt in Prozenten, gegeben wird.

Où le degré d'intermittence (I)% est fourni par le rapport entre le temps de fonction en charge et le temps total ($t_f + t_r$) exprimé en pourcentage.

$$I = \frac{t_f}{t_f + t_r} \cdot 100 \quad (2)$$

La condizione da verificare è:

The condition to be verified is:

Die durchzuführende Kontrolle ist:

La vérification à faire sera la suivante :

$$P_{r1} \leq P_t \times f_t \quad (3)$$

5 - RENDIMENTO

5 - EFFICIENCY

5 - WIRKUNGSGRAD

5 - RENDEMENT

Rendimento dinamico η_d

Dynamic efficiency η_d

Dynamischer Wirkungsgrad η_d

Rendement dynamique η_d

È dato dal rapporto fra la potenza in uscita P_2 e quella in entrata P_1 secondo la relazione:



Obtained from the relationship of delivered power P_2 to input power P_1 , according to the following equation:

Er ist gegeben durch das Verhältnis der Abtriebsleistung P_2 zur Antriebsleistung P_1 :

Il est donné par le rapport entre la puissance en sortie P_2 et celle en entrée P_1 :

$$\eta_d = \frac{P_2}{P_1} \cdot 100 \quad [\%] \quad (4)$$

(A3)

	2 x 	3 x 	4 x 
η_d	94%	91%	89%

6 - RAPPORTO DI RIDUZIONE i

6 - GEAR RATIO i

6 - GETRIEBEÜBERSETZUNG i

6 - RAPPORT DE REDUCTION i

Il valore del rapporto di riduzione della velocità, identificato con il simbolo $[i]$, è espresso tramite il rapporto fra le velocità all'albero veloce e lento del riduttore e riassunto nell'espressione:

The value for the gear ratio is referred to with the letter $[i]$ and calculated through the relationship of the input speed n_1 to the output speed n_2 :

Die Übersetzung des Getriebes wird mit dem Buchstaben $[i]$ bezeichnet und ist folgendermaßen definiert:

Le rapport de réduction est identifiée par la lettre $[i]$ et son calcul s'effectue à partir de la vitesse d'entrée n_1 et de la vitesse de sortie n_2 en utilisant la relation suivante :

$$i = \frac{n_1}{n_2} \quad (5)$$



Il rapporto di riduzione è solitamente un numero decimale che viene rappresentato nel catalogo con una sola cifra decimale, o nessuna nel caso di $i > 1000$. Se si è interessati a conoscere il numero in tutte le componenti decimali consultare il Servizio Tecnico di Bonfiglioli Riduttori.

The gear ratio is usually a decimal number which in this catalogue is truncated at one digit after the comma (no decimals for $i > 1000$). If interested in knowing the exact value please consult Bonfiglioli's Technical Service.

In diesem Katalog wird die Übersetzung mit einer Stelle hinter dem Komma angegeben, bei Übersetzungen > 1000 ohne Dezimalstelle. Wenn genaue Angaben zur Übersetzung benötigt werden, wenden sie sich bitte an den technischen Service von Bonfiglioli Riduttori.

Dans le catalogue, le rapport de réduction a une précision d'un chiffre après la virgule (sauf pour $i > 1000$). Si une plus grande précision est nécessaire, contacter le Service Technique de Bonfiglioli.

7 - VELOCITÀ ANGOLARE

Velocità in entrata
 n_1 [min⁻¹]

È la velocità relativa al tipo di motorizzazione scelta; i valori di catalogo si riferiscono alle velocità dei motori elettrici comunemente usati a singola e doppia polarità.

Se il riduttore riceve il moto da una trasmissione in entrata, è sempre preferibile adottare velocità inferiori a 1400 min⁻¹ al fine di garantire condizioni ottimali di funzionamento.

Velocità in entrata superiori sono ammesse considerando il naturale declassamento della coppia nominale M_{n2} del riduttore.

7 - ANGULAR VELOCITY

Input speed
 n_1 [min⁻¹]

The speed is related to the prime mover selected. Catalogue values refer to speed of either single or double speed motors that are common in the industry.

If the gearbox is driven by an external transmission it is recommended to operate it with a speed of 1400 min⁻¹, or lower, in order to optimise operating conditions and lifetime.

Higher input speeds are permitted, however in this case consider that torque rating M_{n2} is affected adversely. Please consult a Bonfiglioli representative.

7 - DREHZAHL

Drehzahl Antriebswelle
 n_1 [min⁻¹]

Dies ist die vom gewählten Motortyp abhängige Drehzahl.

Die Katalogangaben beziehen sich auf die Drehzahl von allgemeinüblichen eintourigen Elektromotoren oder von polumschaltbaren Elektromotoren.

Um optimale Betriebsbedingungen zu gewährleisten, ist stets eine Antriebsdrehzahl unter 1400 min⁻¹ zu empfehlen.

Höhere Antriebsdrehzahlen sind zulässig, wobei die zwangsläufige Herabsetzung des Nennabtriebsdrehmoments M_{n2} des Getriebes zu berücksichtigen ist.

7 - VITESSE ANGULAIRE

Vitesse d'entrée
 n_1 [min⁻¹]

C'est la vitesse relative au type de motorisation choisie. Les valeurs de catalogue se réfèrent aux vitesses des moteurs électriques à simple et double polarité communément utilisés.

Si le réducteur reçoit le mouvement d'une transmission en entrée, il est toujours préférable d'adopter des vitesses inférieures à 1400 min⁻¹ afin de garantir des conditions optimales de fonctionnement.

Des vitesses d'entrée supérieures sont admises en considérant le déclassement naturel du couple nominal M_{n2} du réducteur.

Velocità in uscita
 n_2 [min⁻¹]

È in funzione della velocità in entrata n_1 e del rapporto di riduzione i secondo la relazione:

Output speed
 n_2 [min⁻¹]

The output speed value n_2 is calculated from the relationship of input speed n_1 to the gear ratio i , as per the following equation:

Abtriebsdrehzahl
 n_2 [min⁻¹]

Sie ist abhängig von der Antriebsdrehzahl n_1 und dem Übersetzungs i nach folgender Gleichung:

Vitesse en sortie
 n_2 [min⁻¹]

Elle varie en fonction de la vitesse d'entrée n_1 et du rapport de réduction i selon l'équation :

$$n_2 = \frac{n_1}{i} \quad (6)$$

8 - MOMENTO D'INERZIA
 J_r [Kgm²]

I momenti d'inerzia indicati a catalogo sono riferiti all'asse di entrata del riduttore per cui, nel caso di accoppiamento diretto, sono già rapportati alla velocità del motore.

8 - MOMENT OF INERTIA
 J_r [Kgm²]

Moments of inertia specified in the catalogue refer to the gear unit input axis. They are therefore related to motor speed, in the case of direct motor mounting.

8 - TRÄGHEITSMOMENT
 J_r [Kgm²]

Die im Katalog angegebenen Trägheitsmomente sind auf die Antriebswelle des Getriebes bezogen und daher im Falle einer direkten Verbindung schon zur Motordrehzahl in Beziehung gesetzt.

8 - MOMENT D'INERTIE
 J_r [Kgm²]

Les moments d'inertie indiqués dans le catalogue se réfèrent à l'axe d'entrée du réducteur par conséquent, dans le cas d'accouplement direct, ils se rapportent déjà à la vitesse du moteur.



9 - FATTORE DI SERVIZIO f_s

Il fattore di servizio è il parametro che traduce in un valore numerico la gravosità del servizio che il riduttore è chiamato a svolgere, tenendo conto, benché con inevitabile approssimazione, del funzionamento giornaliero, della variabilità del carico e di eventuali sovraccarichi, connessi con la specifica applicazione del riduttore.

Nel grafico (A4) più sotto riportato il fattore di servizio si ricava, dopo aver selezionato la colonna relativa alle ore di funzionamento giornaliero, per intersezione fra il numero di avviamenti orari e una fra le curve K1, K2 e K3.

Le curve $K_{_}$ sono associate alla natura del servizio (approssimativamente: uniforme, medio e pesante) tramite il fattore di accelerazione delle masse K , legato al rapporto fra le inerzie delle masse condotte e del motore.

Indipendentemente dal valore così ricavato del fattore di servizio, segnaliamo che esistono applicazioni fra le quali, a puro titolo di esempio i sollevamenti, per le quali il cedimento di un organo del riduttore potrebbe esporre il personale che opera nelle immediate vicinanze a rischio di ferimento.

Se esistono dubbi che l'applicazione possa presentare questa criticità vi invitiamo a consultare preventivamente il ns. Servizio Tecnico.

9 - SERVICE FACTOR f_s

This factor is the numeric value describing reducer service duty. It takes into consideration, with unavoidable approximation, daily operating conditions, load variations and overloads connected with reducer application.

In the graph (A4) below, after selecting proper "daily working hours" column, the service factor is given by intersecting the number of starts per hour and one of the K1, K2 or K3 curves.

$K_{_}$ curves are linked with the service nature (approximately: uniform, medium and heavy) through the acceleration factor of masses K , connected to the ratio between driven masses and motor inertia values.

Regardless of the value given for the service factor, we would like to remind that in some applications, which for example involve lifting of parts, failure of the reducer may expose the operators to the risk of injuries. If in doubt, please contact our Technical Service Department.

9 - BETRIEBSFAKTOR f_s

Beim Betriebsfaktor handelt es sich um den Parameter, der die Betriebsbelastung, die das Getriebe aushalten muss, in einem Wert ausdrückt. Dabei berücksichtigt er, auch wenn nur mit einer unvermeidbaren Annäherung, den täglichen Einsatz, die unterschiedlichen Belastungen und eventuelle Überbelastungen, die mit der spezifischen Applikation des Getriebes verbunden sind. Der nachstehenden Grafik (A4) kann, nach der Wahl der entsprechenden Spalte mit der Angabe der täglichen Betriebsstunden der Betriebsfaktor entnommen werden, indem man die Schnittstelle zwischen der stündlichen Schaltungen und einer der Kurven K1, K2 und K3 sucht.

Die mit $K_{_}$ gekennzeichneten Kurven sind über den Beschleunigungsfaktor der Massen K an die Betriebsart gekoppelt (annähernd: gleichmäßige, mittlere oder starke Belastung), der wiederum an das Verhältnis zwischen Trägheitsmoment der angetriebenen Massen und dem des Motors gebunden ist. Unabhängig von dem so erhaltenen Betriebsfaktor, möchten wir Sie darauf hinweisen, dass es Applikationen gibt, unter denen beispielsweise auch die Hebefunktionen zu finden sind, bei denen das Nachgeben eines Getriebeorgans, das in dessen Nähe arbeitende Personal einer Verletzungsgefahr aussetzen könnte. Sollten daher Zweifel darüber bestehen, ob die entsprechende Applikation sich in diesem Bezug als kritisch erweist, bitten wir Sie sich zuvor mit unseren Technischen Kundendienst in Verbindung zu setzen.

9 - FACTEUR DE SERVICE f_s

Le facteur de service est le paramètre qui traduit en une valeur numérique la difficulté du service que le réducteur est appelé à effectuer en tenant compte, avec une approximation inévitable, du fonctionnement journalier, de la variabilité de la charge et des éventuelles surcharges liées à l'application spécifique du réducteur.

Sur le graphique (A4) ci-dessous, le facteur de service peut être trouvé, après avoir sélectionné la colonne relative aux heures de fonctionnement journalier, à l'intersection entre le nombre de démarrages horaires et l'une des courbes K1, K2 et K3.

Les courbes $K_{_}$ sont associées à la nature du service (approximativement: uniforme, moyen et difficile) au moyen du facteur d'accélération des masses K , lié au rapport entre les inerties des masses conduites et le moteur.

Indépendamment de la valeur du facteur de service ainsi trouvée, nous signalons qu'il existe des applications parmi lesquelles, à titre d'exemple, les levages, pour lesquels la rupture d'un organe du réducteur pourrait exposer le personnel opérant à proximité immédiate à des risques de lésion.

En cas de doute concernant les risques éventuels de l'application, nous vous conseillons de contacter préalablement notre Service Technique.

(A4)

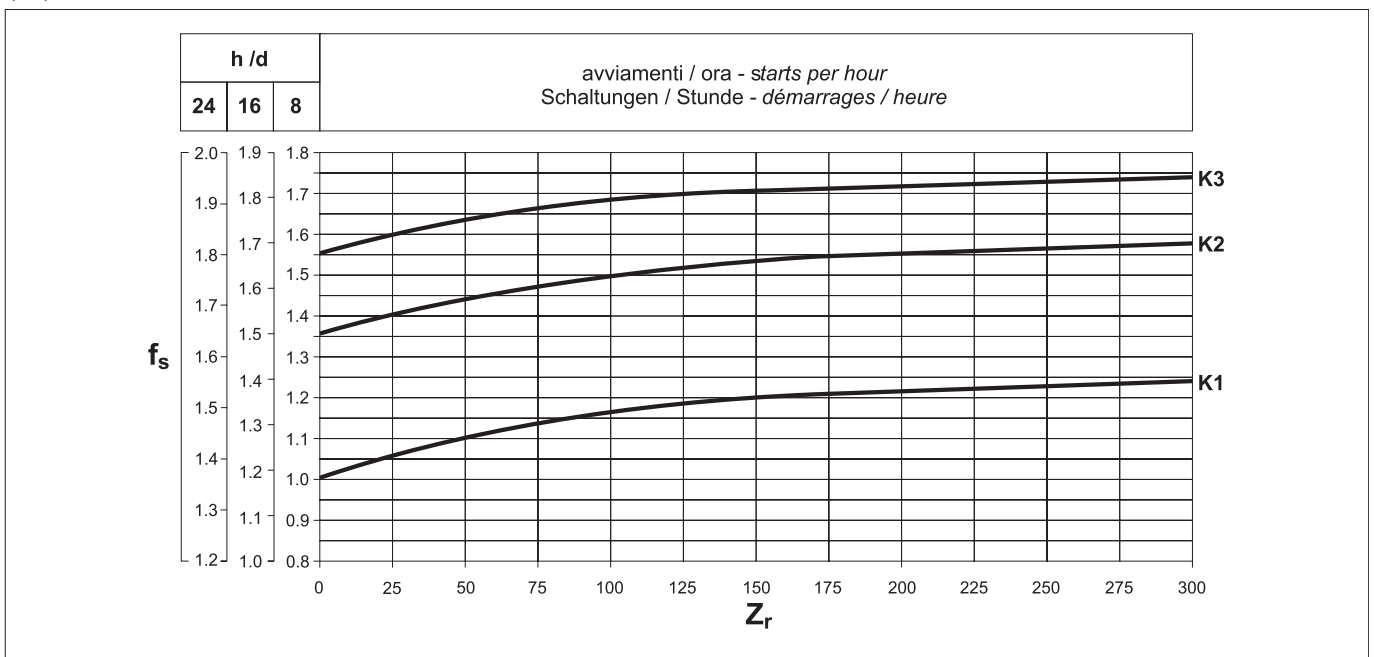



Fattore di accelerazione delle masse, K	Acceleration factor of masses, K	Beschleunigungsfaktor der Massen, K	Facteur d'accélération des masses, K
Il parametro serve a selezionare la curva relativa al particolare tipo di carico. Il valore è dato dal rapporto:	<i>This parameter serves for selecting the right curve for the type of load. The value is given by the following ratio:</i>	Dieser Parameter dient der Wahl der Kurve, die sich auf die jeweilige Belastungsart bezieht. Der Wert ergibt sich aus folgender Formel:	<i>Le paramètre sert à sélectionner la courbe relative au type de charge particulier. La valeur est obtenue par l'équation :</i>

$K = \frac{J_c}{J_m}$	→ $J_c =$	Momento d'inerzia delle masse comandate, riferito all'albero motore	<i>Moment of inertia of driven masses referred to motor drive shaft</i>	Trägheitsmoment der angetriebenen Massen, bezogen auf die Motorwelle	<i>Moment d'inertie des masses commandées se référant à l'arbre du moteur</i>
	$J_m =$	Momento d'inerzia del motore	<i>Motor moment of inertia</i>	Trägheitsmoment des Motors	<i>Moment d'inertie du moteur</i>
$K \leq 0,25$	→ K1	Carico uniforme	<i>Uniform load</i>	Gleichmäßige Belastung	<i>Charge uniform</i>
$0,25 < K \leq 3$	→ K2	Carico con urti moderati	<i>Moderate shock load</i>	Belastung mit mäßigen Stößen	<i>Charge avec chocs modérés</i>
$3 < K \leq 10$	→ K3	Carico con forti urti	<i>Heavy shock load</i>	Belastung mit starken Stößen	<i>Charge avec chocs importants</i>
$K > 10$	→	Consultare il Servizio Tecnico di Bonfiglioli	<i>Please consult Bonfiglioli Technical Service</i>	Bitten wir Sie, sich mit unserem Technischen Kundendienst in Verbindung zu setzen	<i>Contacter le Service Technique du Bonfiglioli</i>

10 - MANUTENZIONE

I riduttori forniti con lubrificazione permanente non necessitano di sostituzioni periodiche dell'olio.
Per gli altri si consiglia di effettuare una prima sostituzione del lubrificante dopo circa 300 ore di funzionamento provvedendo ad un accurato lavaggio interno del gruppo con adeguati detergenti. Evitare di miscelare olii a base minerale con olii sintetici.
Controllare periodicamente il livello del lubrificante effettuando la sostituzione indicativamente agli intervalli riportati nella tabella (A5).

10 - MAINTENANCE

*Life lubricated gearboxes do not require any periodical oil changes.
For other types of gearboxes, the first oil change must take place after about 300 hours of operation, carefully flushing the gear unit using suitable detergents.
Do not mix mineral oils with synthetic oils.
Check oil level regularly and change oil at the intervals shown in the table (A5).*

10 - WARTUNG

Die mit Dauerschmierung gelieferten Getriebe bedürfen periodische Ölwechsel.
Bei den übrigen Getrieben wird ein erster Ölwechsel nach ca. 300 Betriebsstunden empfohlen, wobei das Innere der Gruppe sorgfältig mit einem geeigneten Reinigungsmittel zu waschen ist.
Mineralöle nicht mit Syntheseölen mischen.
Den Ölstand regelmäßig kontrollieren. Die Ölwechsel in den in der Tabelle (A5) angegebenen Fristen durchführen.

10 - ENTRETIEN

*Les réducteurs fournis avec lubrification permanente n'ont besoin d'aucun remplacement périodique de huile.
Pour les autres, nous conseillons d'effectuer une première vidange du lubrifiant après les 300 premières heures de fonctionnement en réalisant un lavage soigné à l'intérieur du groupe avec des produits détergents appropriés.
Eviter de mélanger les huiles à base minérale avec des huiles synthétiques.
Contrôler périodiquement le niveau du lubrifiant en effectuant les vidanges conformément aux intervalles indiqués dans le tableau (A5).*

(A5)

Temperatura olio / Oil temperature Öltemperatur / Température huile [°C]	Intervallo di lubrificazione / Oil change interval Schmierfrist / Intervalle de lubrification [h]	
	olio minerale / mineral oil Mineralöl / huile minérale	olio sintetico / synthetic oil Syntheseöl / huile synthétique
< 65	8000	25000
65 - 80	4000	15000
80 - 95	2000	12500



11 - SELEZIONE

11 - SELECTION

11 - ANTRIEBSAUSWAHL

11 - SELECTION

Per selezionare correttamente un riduttore o un motoriduttore, è necessario disporre di alcuni dati fondamentali che sono sintetizzati nella tabella (A6). In particolare, essa potrà essere compilata ed inviata in copia al ns. Servizio Tecnico che provvederà alla ricerca della motorizzazione più idonea alla applicazione indicata.

Some fundamental data are necessary to assist the correct selection of a gearbox or gearmotor. The table below (A6) briefly sums up this information. To simplify selection, fill in the table and send a copy to our Technical Service which will select the most suitable drive unit for your application.

Um die Getriebe und Getriebemotoren richtig auszuwählen zu können, muß man über einige grundlegende Daten verfügen, die wir in der Tabelle (A6) zusammengefaßt haben. Eine Kopie dieser vom Kunden ausgefüllten Tabelle kann an unseren Technischen Kundendienst geschickt werden, der dann die für die gewünschte Anwendung geeignete Auslegung wählt.

Pour sélectionner correctement un réducteur ou un motoréducteur, il est nécessaire de disposer de certaines données fondamentales que nous avons résumé dans le tableau (A6). En particulier, ce dernier pourra être rempli et retourné à notre service technique qui recherchera la motorisation la plus appropriée à l'application indiquée.

(A6)

Tipo di applicazione / Type of application / Anwendung / Type d'application			
P _{r2}	Potenza in uscita a n ₂ max Output power at n ₂ max Abtriebsleistung bei n ₂ max Puissance en sortie à n ₂ maxikW	Senso di rotazione albero entrata (O-AO) (**) Input shaft rotation direction (CW-CCW) (**) Drehrichtung der Antriebswelle (U-GU) (**) Sens de rotation arbre entrée (H-AH) (**)
P _{r2'}	Potenza in uscita a n ₂ min Output power at n ₂ min Abtriebsleistung bei n ₂ min Puissance en sortie à n ₂ minikW	A _{c2} Carico assiale su albero in uscita (+/-)(***) Thrust load on output shaft (+/-)(***) Axialkraft auf Abtriebswelle (+/-)(***) Charge axiale sur arbre de sortie (+/-)(***)
M _{r2}	Momento torcente in uscita a n ₂ max Output torque at n ₂ max Abtriebsdrehmoment bei n ₂ max Moment de torsion en sortie à n ₂ maxiNm	A _{c1} Carico assiale su albero in entrata (+/-)(***) Thrust load on input shaft (+/-)(***) Axialkraft auf Antriebswelle (+/-)(***) Charge axiale sur arbre d'entrée (+/-)(***)
n ₂	Velocità di rotazione in uscita max Max.output speed Abtriebsdrehzahl max Vitesse de rotation maxi en sortiemin ⁻¹	J _c Momento d'inerzia del carico Moment of inertia of the load Trägheitsmoment der Last Moment d'inertie de la charge
n _{2'}	Velocità di rotazione in uscita min Min.output speed Abtriebsdrehzahl min Vitesse de rotation mini en sortiemin ⁻¹	t _a Temperatura ambiente Ambient temperature Umgebungstemperatur Température ambiante
n ₁	Velocità di rotazione in entrata max Max.input speed Antriebsdrehzahl max Vitesse de rotation maxi en entréemin ⁻¹	Altitudine sul livello del mare Altitude above sea level Höhe ü.d.M. Altitude au-dessus du niveau de la mer
n _{1'}	Velocità di rotazione in entrata min Min.input speed Antriebsdrehzahl min Vitesse de rotation mini en entréemin ⁻¹	Tipo di servizio in accordo a CEI Duty type to IEC norms Relative Einschaltdauer gemäß CEI Type de service selon CEI
R _{c2}	Carico radiale su albero in uscita Radial load on output shaft Radialkraft auf Abtriebswelle Charge radiale sur arbre de sortieN	Z Frequenza di avviamento Starting frequency Schaltungshäufigkeit Fréquence de démarrage
x ₂	Distanza di applicazione del carico (*) Load application distance (*) Abstand des Kraftangriffspunktes (*) Distance d'application de la charge (*)mm	Tensione di alimentazione motore Motor voltage Nennspannung des Motors Tension de alimentation moteur
	Orientamento del carico in uscita Load orientation at output Orientierung der Last am Abtrieb Orientation de la charge en sortie		Tensione di alimentazione freno Brake voltage Nennspannung der Bremse Tension de alimentation frein
	Senso di rotazione albero uscita (O-AO) (**) Output shaft rotation direction (CW-CCW) (**) Drehrichtung der Abtriebswelle (U-GU) (**) Sens de rotation arbre sortie (H-AH) (**)	Frequenza Frequency Frequenz Fréquence
R _{c1}	Carico radiale su albero in entrata Radial load on input shaft Radialkraft auf Antriebswelle Charge radiale sur arbre d'entréeN	M _b Coppia frenante Brake torque Bremsmoment Couple de freinage
x ₁	Distanza di applicazione del carico (*) Load application distance (*) Abstand des Kraftangriffspunktes (*) Distance d'application de la charge (*)mm	Grado di protezione motore Motor protection degree Schutzart des Motors Degré de protection moteur
	Orientamento del carico in entrata Load orientation at input Orientierung der Last am Antrieb Orientation de la charge en entrée		Classe di isolamento Insulation class Isolierstoffklasse Classe d'isolation

(*) La distanza x₁₋₂ è quella compresa fra il punto di applicazione della forza e la battuta dell'albero (se non indicata, si considererà la forza agente sulla mezzieria della sporgenza dell'albero).
(**) O = orario
AO = antiorario
(***) + = compressione
- = trazione

(*) Distance x₁₋₂ is between force application point and shaft shoulder (if not indicated the force acting at mid-point of the shaft extension will be considered).
(**) CW = clockwise;
CCW = counterclockwise
(***) + = push
- = pull

(*) Der Abstand x₁₋₂ ist der Abstand vom Kraftangriffspunkt zum Wellenansatz (wenn nicht anders angegeben, wird davon ausgegangen, daß die Kraft auf der Mitte des Wellenendes angreift).
(**) U = Uhrzeigersinn;
GU = Gegenurzeigersinn
(***) + = Druck
- = Zug

(*) La distance x₁₋₂ est celle comprise entre le point d'application de la force et l'épaulement de l'arbre (si non précisée l'on considerera la force agissant au milieu de la saillie de l'arbre).
(**) H = sens horaire;
AH = sens antihoraire
(***) + = compression
- = traction



Scelta dei motoriduttori	Selection of a gearmotor	Wahl des Getriebemotors	Sélection des motoréducteurs
---------------------------------	---------------------------------	--------------------------------	-------------------------------------

- | | | | |
|---|---|---|---|
| <p>a) Determinare il fattore di servizio f_s in funzione del tipo di carico (fattore K), del numero di inserzioni/ora Z_r e del numero di ore di funzionamento.</p> <p>b) Dalla coppia M_{r2}, conoscendo n_2 e il rendimento dinamico η_d, ricavare la potenza in entrata.</p> | <p>a) <i>Determine service factor f_s according to type of duty (factor K), number of starts per hour Z_r and hours of operation.</i></p> <p>b) <i>From values of torque M_{r2}, speed n_2 and efficiency η_d the required input power can be calculated from the equation:</i></p> | <p>a) Den Betriebsfaktor f_s in Abhängigkeit von der Belastungsart (Faktor K), den Schaltungen /Stunde Z_r und den Betriebsstunden bestimmen.</p> <p>b) Aus dem Drehmoment M_{r2} mit Hilfe der bekannten Werte für n_2 und dem dynamischen Wirkungsgrad η_d die Antriebsleistung ableiten.</p> | <p>a) <i>Déterminer le facteur de service f_s en fonction du type de charge (facteur K), du nombre d'insertions/heure Z_r et du nombre d'heures de fonctionnement.</i></p> <p>b) <i>A partir du couple M_{r2}, en connaissant n_2 et le rendement dynamique η_d, calculer la puissance en entrée.</i></p> |
|---|---|---|---|

$$P_{r1} = \frac{M_{r2} \cdot n_2}{9550 \cdot \eta_d} \text{ [kW]} \quad (7)$$

Il valore di η_d per lo specifico riduttore può essere ricavato dal paragrafo 5.

Value of η_d for the captioned gear unit can be sorted out from paragraph 5.

Für das spezifische Getriebe kann der Wert η_d unter Paragraph 5 erhoben werden.

Il valeur de η_d pour le réducteur spécifique peut être calculée d'après les indications du paragraphe 5.

- | | | | |
|--|--|--|---|
| <p>c) Ricercare fra le tabelle dei dati tecnici motoriduttori quella corrispondente ad una potenza normalizzata P_n tale che:</p> | <p>c) <i>Consult the gearmotor selection charts and locate the table corresponding to normalised power P_n.</i></p> | <p>c) Unter den Tabellen mit den Technischen Daten der Getriebemotoren die Tabelle auswählen, die folgender Leistung entspricht:</p> | <p>c) <i>Rechercher parmi les tableaux des caractéristiques techniques des motoréducteurs celui correspondant à une puissance :</i></p> |
|--|--|--|---|

$$P_n \geq P_{r1} \quad (8)$$

Se non diversamente indicato, la potenza P_n dei motori riportata a catalogo si riferisce al servizio continuo S1. Per i motori utilizzati in condizioni diverse da S1, sarà necessario identificare il tipo di servizio previsto con riferimento alle Norme CEI 2-3/IEC 34-1. In particolare, per i servizi da S2 a S8 e per le grandezze motore uguali o inferiori a 132, è possibile ottenere una maggiorazione della potenza rispetto a quella prevista per il servizio continuo, pertanto la condizione da soddisfare sarà:

Unless otherwise specified, power P_n of motors indicated in the catalogue refers to continuous duty S1. For motors used in conditions other than S1, the type of duty required by reference to CEI 2-3/IEC 34-1 Standards must be mentioned. For duties from S2 to S8 in particular and for motor frame 132 or smaller, extra power output can be obtained with respect to continuous duty. Accordingly the following condition must be satisfied:

Wenn nicht anders angegeben, bezieht sich die im Katalog angegebene Leistung P_n der Motoren auf Dauerbetrieb S1. Bei Motoren, die unter anderen Bedingungen als S1 eingesetzt werden, muß die vorgesehen Betriebsart unter Bezug auf die CEI-Normen 2-3/IEC 34-1 bestimmt werden. Insbesondere kann man für die Betriebsarten S2 bis S8 (und für Motorbaugrößen gleich oder niedriger als 132) eine Überdimensionierung der Leistung relativ zu der für den Dauerbetrieb vorgesehenen Leistung erhalten; die zu erfüllende Bedingung ist dann:

Sauf indication contraire la puissance P_n des moteurs indiquée dans le catalogue se réfère à un service continu S1. Pour les moteurs utilisés dans des conditions différentes du service S1, il sera nécessaire d'identifier le type de service prévu en se référant aux normes CEI 2-3/IEC 34-1. En particulier, pour les services de type S2 à S8 ou pour les tailles de moteurs égales ou inférieures à 132 il est possible d'obtenir une majoration de la puissance par rapport à celle prévue pour le service continu. Par conséquent, la condition à satisfaire sera :

$$P_n \geq \frac{P_{r1}}{f_m} \quad (9)$$

Il fattore di maggiorazione f_m è ricavabile dalla tabella (A7).

The adjusting factor f_m can be obtained from table (A7).

Der Überdimensionierungsfaktor f_m kann der Tabelle (A7) entnommen werden.

Le facteur de majoration f_m peut être obtenu en consultant le tableau (A7).



Rapporto di intermittenza

Intermittence ratio

Relative Einschaltdauer

Rapport d'intermittence

$$I = \frac{t_f}{t_f + t_r} \cdot 100 \quad (10)$$

t_f = tempo di funzionamento a carico costante
 t_r = tempo di riposo

t_f = work time at constant load
 t_r = rest time

t_f = Betriebszeit mit konstanter Belastung
 t_r = Aussetzzeit

t_f = temps de fonctionneent à charge constante
 t_r = temps de repos

(A7)

	SERVIZIO / DUTY / BETRIEB / SERVICE						
	S2			S3*			S4 - S8
	Durata del ciclo / Cycle duration [min] Zyklusdauer / Durée du cycle [min]			Rapporto di intermittenza / Cyclic duration factor (I) Relative Einschaltdauer / Rapport d'intermittence (I)			
f_m	10	30	60	25%	40%	60%	Interpellarci Please contact us Rückfrage Nous contacter
	1.35	1.15	1.05	1.25	1.15	1.1	

* La durata del ciclo dovrà comunque essere uguale o inferiore a 10 minuti; se superiore interpellare il Servizio Tecnico di Bonfiglioli Riduttori.

* Cycle duration, in any event, must be 10 minutes or less. If it is longer, please contact our Technical Service.

* Die Zyklusdauer muß in jedem Fall kleiner oder gleich 10 min sein; wenn sie darüber liegt, unseren Technisch en Kundendienst zu Rate ziehen.

* La durée du cycle devra être égale ou inférieure à 10 minutes. Si supérieure, contacter notre Service Technique.

Nella sezione relativa alla potenza installata P_n selezionare infine il motoriduttore che sviluppa la velocità di funzionamento più prossima alla velocità n_2 desiderata e per il quale il fattore di sicurezza S sia uguale, o superiore, al fattore di servizio f_s .

Next, refer to the appropriate P_n section within the gearmotor selection charts and locate the unit that features the desired output speed n_2 , or closest to, along with a safety factor S that meets or exceeds the applicable service factor f_s .

Als nächstes wählen Sie anhand der Getriebemotoren auswahltabellen den Abschnitt mit der entsprechenden P_n und suchen die gewünschte Abtriebsdrehzahl n_2 , oder die nächstmögliche Drehzahl, zusammen mit dem Sicherheitsfaktor S , der den zutreffenden Betriebsfaktor f_s erreicht oder überschreitet.

Dans la section relative à la puissance installée P_n sélectionner enfin le motoréducteur qui développe la vitesse de fonctionnement la plus proche à la vitesse n_2 désirée et pour lequel le facteur de sécurité S soit pareil, ou supérieur, au facteur de service f_s .

Il fattore di sicurezza è così definito:

The safety factor is so defined:

Der Sicherheitsfaktor wird wie folgt berechnet:

Le facteur de sécurité est défini ainsi :

$$S = \frac{M_{n2}}{M_2} = \frac{P_{n1}}{P_1} \quad (11)$$

Nelle tabelle di selezione motoriduttori gli abbinamenti sono sviluppati con motori a 2, 4 e 6 poli alimentati a 50 Hz. Per velocità di comando diverse da queste, effettuare la selezione con riferimento ai dati nominali forniti per i riduttori.

As standard, gear and motor combinations are implemented with 2, 4 and 6 pole motors, 50 Hz supplied. Should the drive speed be different from 2800, 1400 or 900 min⁻¹, base the selection on the gear unit nominal rating.

Standardmäßig stehen Getriebemotorenkombinationen mit 2, 4 und 6 poligen Motoren für eine Frequenz von 50 Hz zur Verfügung. Sollten die Antriebsdrehzahlen abweichend von 2800, 1400 oder 900 min⁻¹ sein, dann stützen Sie die Auslegung des Getriebes auf die Getriebe-nendaten.

Dans les tableaux de sélection des motoréducteurs les accouplements sont développés avec moteurs à 2, 4 et 6 poles alimentés à 50 Hz. Pour vitesses de commande différentes à celles-ci, sélectionner suite aux données nominales fournies par les réducteurs.

Scelta dei riduttori e dei riduttori predisposti per motori IEC

Selection of speed reducer and gearbox with IEC motor adapter

Wahl des Getriebes und Getriebe für IEC-motoren

Sélection des réducteurs et des réducteurs IEC

- a) Determinare il fattore di servizio f_s .
- b) Conoscendo la coppia M_{r2} di uscita richiesta dalla applicazione, si procede alla definizione della coppia di calcolo:

- a) Determine service factor f_s .
- b) Assuming the required output torque for the application M_{r2} is known, the calculation torque can be then defined as:

- a) Den Betriebsfaktor f_s bestimmen.
- b) Anhand des bekannten von der Anwendung geforderten Abtriebsdrehmoments M_{r2} das Soll-Drehmoment bestimmen:

- a) Déterminer le facteur de service f_s .
- b) En connaissant le couple M_{r2} de sortie requis par l'application, l'on procède à la définition du couple de calcul :

$$M_{c2} = M_{r2} \cdot f_s \quad (12)$$



c) In base alla velocità in uscita n_2 richiesta, e a quella in entrata n_1 disponibile, si calcola il rapporto di riduzione:

c) *The gear ratio is calculated according to requested output speed n_2 and drive speed n_1 :*

c) Auf Grundlage der verlangten Abtriebsdrehzahl n_2 und der verfügbaren Antriebsdrehzahl n_1 die Übersetzungsberechnen:

c) *Suivant la vitesse en sortie n_2 requise et celle en entrée n_1 disponible, l'on calcule le rapport de réduction :*

$$i = \frac{n_1}{n_2} \quad (13)$$

Disponendo dei dati M_{c2} e i , si ricercherà nelle tabelle corrispondenti alla velocità n_1 il riduttore che, in funzione del rapporto $[i]$ più prossimo a quello calcolato, proponga una coppia nominale:

Once values for M_{c2} and i are known consult the rating charts under the appropriate input speed n_1 and locate the gear unit that features the gear ratio closest to $[i]$ and at same time offers a rated torque value M_{n2} so that:

Anhand der Werte für M_{c2} und i in den Tabellen für die Drehzahl n_1 das Getriebe auswählen, das in Abhängigkeit von einer Übersetzung $[i]$, die dem Sollwert möglichst nahe ist, folgendes Nenn-Drehmoment erlaubt:

En disposant des données M_{c2} et i , l'on recherchera dans les tableaux correspondant à la vitesse n_1 le réducteur qui, en fonction du rapport $[i]$ le plus proche de celui calculé, propose un couple nominal :

$$M_{n2} \geq M_{c2} \quad (14)$$

Se al riduttore scelto dovrà essere applicato un motore elettrico verificarne l'applicabilità consultando la tabella delle predisposizioni possibili al paragrafo 31.

If a IEC normalized motor must be fitted check geometrical compatibility with the gear unit at paragraph 31 - Motor availability.

Wenn das Getriebe mit einem Elektromotor verbunden werden soll, die Verträglichkeit anhand der Tabelle der möglichen Anbaumöglichkeiten sicherstellen.

Au cas où il serait nécessaire d'appliquer un moteur électrique normalisé au réducteur choisi, en vérifier la possible adaptation en consultant le tableau des prédispositions possibles présenté.

12 - VERIFICHE

Effettuata la selezione del riduttore, o motoriduttore, è opportuno procedere alle seguenti verifiche:

a) **Potenza termica**
Assicurarsi che la potenza termica del riduttore, abbia un valore uguale o maggiore alla potenza richiesta dall'applicazione secondo la relazione (3) a pag. 6, in caso contrario selezionare un riduttore di grandezza superiore oppure provvedere ad applicare un sistema di raffreddamento forzato.

b) **Coppia massima**
Generalmente la coppia massima (intesa come punta di carico istantaneo) applicabile al riduttore non deve superare il 200% della coppia nominale M_{n2} ; verificare pertanto che tale limite non venga superato adottando, se necessario, opportuni dispositivi per la limitazione della coppia.

12 - VERIFICATION

After the selection of the speed reducer, or gearmotor, is complete it is recommended that the following verifications are conducted:

a) **Thermal capacity**
Make sure that the thermal capacity of the gearbox is equal to or greater than the power required by the application according to equation (3) on page 6. If this condition is not verified, select a larger gearbox or apply a forced cooling system.

b) **Maximum torque**
The maximum torque (intended as instantaneous peak load) applicable to the gearbox must not, in general, exceed 200% of rated torque M_{n2} . Therefore, check that this limit is not exceeded, using suitable torque limiting devices, if necessary.

12 - PRÜFUNGEN

Nachdem die Auswahl des Getriebe oder Getriebemotor abgeschlossen ist, werden die folgenden Schritte empfohlen:

a) **Thermische Grenzleistung**
Sicherstellen, daß die Wärmeleistung des Getriebes größer oder gleich der verlangten Leistung ist, die von der Anwendung nach Gleichung (3) auf S. 6 verlangt wird. Andernfalls ein größer dimensioniertes Getriebe wählen bzw. ein Zwangskühlsystem vorsehen.

b) **Max. Drehmoment**
Im allgemeinen darf das max. Drehmoment (verstanden als momentane Lastspitze), das auf das Getriebe aufgebracht werden kann, 200% des Nenn Drehmoments M_{n2} nicht überschreiten. Sicherstellen, daß dieser Grenzwert nicht überschritten wird, und nötigenfalls die entsprechenden Vorrichtungen zur

12 - VERIFICATIONS

Une fois effectuée la sélection du réducteur, ou motoréducteur, il faut procéder aux suivantes vérifications :

a) **Puissance thermique**
S'assurer que la puissance thermique du réducteur ait une valeur supérieure ou égale à la puissance requise par l'application selon l'équation (3) page 6. Dans le cas contraire, sélectionner un réducteur de taille supérieure ou bien prévoir un système de refroidissement forcé.

b) **Couple maximum**
Généralement, le couple maximum (à considérer comme une pointe de charge instantanée) applicable au réducteur ne doit pas dépasser les 200% du couple nominal M_{n2} . Vérifier par conséquent que cette limite ne soit pas dépassée en adoptant, si nécessaire, des dispositifs adaptés pour limiter le couple.



Per i motori trifase a doppia polarità è necessario rivolgere particolare attenzione alla coppia di commutazione istantanea che viene generata durante la commutazione dall'alta velocità alla bassa in quanto può essere decisamente più elevata della coppia massima stessa. Un metodo semplice ed economico per ridurre tale coppia è quello di alimentare solo due fasi del motore durante la commutazione (il tempo di alimentazione a due fasi può essere regolato mediante un relè a tempo):

$M_{G2} = 0.5 \cdot M_{G3}$
 M_{G2} = Coppia di commutazione alimentando 2 fasi
 M_{G3} = Coppia di commutazione alimentando 3 fasi

Suggeriamo comunque di contattare il ns. Servizio Tecnico.

For three-phase double speed motors, it is important to pay attention to the switching torque which is generated when switching from high to low speed, because it could be significantly higher than maximum torque. A simple, economical way to minimize overloading is to power only two phases of the motor during switch-over (power-up time on two phases can be controlled with a time-relay):

$M_{G2} = 0.5 \cdot M_{G3}$
 M_{G2} = Switching torque with two-phase power-up
 M_{G3} = Switching torque with three-phase power-up

We recommend, in any event, to contact our Technical Service.

Begrenzung des Drehmoments vorsehen. Bei polumschaltbaren Drehstrommotoren muss dem Umschalt Drehmoment, das beim Umschalten von der hohen auf die niedrige Drehzahl erzeugt wird, besondere Aufmerksamkeit geschenkt werden, da es entschieden größer sein kann als das Nenn-Drehmoment. Eine einfache und kostengünstige Methode zum Senken dieses Drehmoments besteht darin, daß nur zwei Phasen des Motors während des Umschaltens gespeist werden (die Dauer der Speisung von nur 2 Phasen kann durch ein Zeitrelais gesteuert werden):

$M_{G2} = 0.5 \cdot M_{G3}$
 M_{G2} = Umschalt Drehmoment bei Speisung von 2 Phasen;
 M_{G3} = Umschalt Drehmoment bei Speisung von 3 Phasen

Wir empfehlen jedoch in jedem Fall, unseren Technischen Kundendienst zu Rate zu ziehen.

Pour les moteurs triphasés à double polarité, il est nécessaire de prêter une attention particulière au couple de commutation instantané qui est généré lors du passage de la grande à la petite vitesse étant donné qu'il peut être considérablement plus élevé que le couple maximum lui même. Une méthode simple et économique pour réduire ce couple consiste à alimenter seulement deux phases du moteur pendant la commutation (la durée d'alimentation sur deux phases peut être réglée au moyen d'un relais temporisateur) :

$M_{G2} = 0.5 \cdot M_{G3}$
 M_{G2} = Couple de commutation en alimentant deux phases
 M_{G3} = Couple de commutation en alimentant trois phases

Nous suggérons cependant de contacter notre Service Technique.

c) Carichi radiali

Verificare che i carichi radiali agenti sugli alberi di entrata e/o uscita rientrino nei valori di catalogo ammessi. Se superiori, aumentare la grandezza del riduttore oppure modificare la supportazione del carico. Ricordiamo che tutti i valori indicati nel catalogo si riferiscono a carichi agenti sulla mezzeria della sporgenza dell'albero in esame per cui, in fase di verifica, è indispensabile tenere conto di questa condizione provvedendo, se necessario, a determinare con le apposite formule il carico ammissibile alla distanza x_{1-2} desiderata. A tale proposito si rimanda ai paragrafi relativi ai carichi radiali.

c) Radial loads

Make sure that radial forces applying on input and/or output shaft are within permitted catalogue values. If they were higher consider designing a different bearing arrangement before switching to a larger gear unit. Catalogue values for rated overhung loads refer to mid-point of shaft under study. Should application point of the overhung load be localised further out the revised loading capability must be adjusted as per instructions given in this manual. See paragraph 22.

c) Radialkräfte

Sicherstellen, daß die auf die Antriebswellen und/oder Abtriebswellen wirkenden Radialkräfte innerhalb der zulässigen Katalogwerte liegen. Wenn sie höher sind, das Getriebe größer dimensionieren bzw. die Abstützung der Last verändern. Wir erinnern daran, daß alle im Katalog angegebenen Werte sich auf Kräfte beziehen, die auf die Mitte des Wellenendes wirken. Diese Tatsache muß bei der Prüfung unbedingt berücksichtigt werden und nötigenfalls muß mit Hilfe der geeigneten Formeln die zulässige Kraft beim gewünschten Abstand x_{1-2} bestimmt werden. Siehe hierzu die Erläuterungen zu den Radialkräften in diesem Katalog.

c) Charges radiales

Vérifier que les charges radiales agissant sur les arbres d'entrée et/ou de sortie se situent dans les valeurs de catalogue admises. Si elles sont supérieures, choisir la taille du réducteur supérieure ou modifier la reprise de charge. Rappelons que toutes les valeurs indiquées dans le catalogue se réfèrent à des charges agissant au milieu de la longueur disponible de l'arbre contrôlé. Par conséquent, en phase de vérification, il est indispensable de prendre en considération cette condition en déterminant, si nécessaire, avec les formules appropriées, la charge admissible à la distance x_{1-2} désirée. Se rapporter à ce propos aux paragraphes relatifs aux charges radiales.

d) Carichi assiali

Anche gli eventuali carichi assiali dovranno essere confrontati con i valori ammissibili. Se si è in presenza di carichi assiali molto elevati o combinati con carichi radiali, si consiglia di interpellare il ns. Servizio Tecnico.

d) Thrust loads

Actual thrust load must be found within 20% of the equivalent overhung load capacity. Should an extremely high, or a combination of radial and axial load apply, consult Bonfiglioli Technical Service.

d) Axialkräfte

Auch die eventuell vorhandenen Axialkräfte müssen mit den im Katalog angegebenen zulässigen Werten verglichen werden. Wenn sehr hohe Axialkräfte wirken oder Axialkräfte in Kombination mit Radialkräften, bitte unseren Technischen Kundendienst zu Rate ziehen.

d) Charges axiales

Les éventuelles charges axiales devront être comparées avec les valeurs admissibles. Si l'on est en présence de charges axiales très élevées ou combinées avec des charges radiales, nous conseillons d'interpeller notre Service Technique.



- | | | | |
|---|---|--|--|
| <p>e) Avviamenti orari</p> <p>Per servizi diversi da S1, con un numero rilevante di inserzioni/ora si dovrà tener conto di un fattore Z (determinabile con le indicazioni riportate nel capitolo dei motori) il quale definisce il numero max. di avviamenti specifico per l'applicazione in oggetto.</p> | <p>e) <i>Starts per hour</i></p> <p><i>For duties featuring a high number of switches the actual starting capability in loaded condition [Z] must be calculated.</i></p> <p><i>Actual number of starts per hour must be lower than value so calculated.</i></p> | <p>e) Schaltungen/Stunde</p> <p>Bei anderen Betriebsarten als S1 mit einem hohen Wert für die Schaltungen/Stunde muß der Faktor Z berücksichtigt werden (er kann mit Hilfe der Angaben im Kapitel Motoren bestimmt werden), der die max. zulässige Anzahl von Schalten für eine bestimmte Anwendung definiert.</p> | <p>e) <i>Démarrages/heure</i></p> <p><i>Pour les services différents de S1, avec un nombre important d'insertions/heure, il faudra prendre en considération un facteur Z (déterminé à l'aide des informations reportées dans le chapitre des moteurs) qui définit le nombre maximum de démarrages spécifique pour l'application concernée.</i></p> |
|---|---|--|--|

13 - INSTALLAZIONE

È molto importante, per l'installazione del riduttore, attenersi alle seguenti norme:

- a) Assicurarsi che il fissaggio del riduttore, sia stabile onde evitare qualsiasi vibrazione. Installare (se si prevedono urti, sovraccarichi prolungati o possibili bloccaggi) giunti idraulici, frizioni, limitatori di coppia, ecc.
- b) Durante la verniciatura si dovranno proteggere i piani lavorati e il bordo esterno degli anelli di tenuta per evitare che la vernice ne essichi la gomma, pregiudicando la tenuta del paraolio stesso.
- c) Gli organi che vanno calati sugli alberi di uscita del riduttore devono essere lavorati con tolleranza ISO H7 per evitare accoppiamenti troppo bloccati che, in fase di montaggio potrebbero danneggiare irrimediabilmente il riduttore stesso. Inoltre, per il montaggio e lo smontaggio di tali organi si consiglia l'uso di adeguati tiranti ed estrattori utilizzando il foro filettato posto in testa alle estremità degli alberi.
- d) Le superfici di contatto dovranno essere pulite e trattate con adeguati protettivi prima del montaggio, onde evitare

13 - INSTALLATION

The following installation instructions must be observed:

- a) *Make sure that the gearbox is correctly secured to avoid vibrations.*
- If shocks or overloads are expected, install hydraulic couplings, clutches, torque limiters, etc.*
- b) *Before being paint coated, the machined surfaces and the outer face of the oil seals must be protected to prevent paint drying out the rubber and jeopardising the sealing function.*
- c) *Parts fitted on the gearbox output shaft must be machined to ISO H7 tolerance to prevent interference fits that could damage the gearbox itself.*
- Further, to mount or remove such parts, use suitable pullers or extraction devices using the tapped hole located at the top of the shaft extension.*
- d) *Mating surfaces must be cleaned and treated with suitable protective products before mounting to avoid*

13 - INSTALLATION

Für die Installation des Getriebes ist es äußerst wichtig, daß folgende Normen beachtet werden:

- a) Sicherstellen, daß die Befestigung des Getriebes stabil ist, damit keine Schwingungen entstehen. Wenn es voraussichtlich zu Stößen, längerdauernden Überlasten oder zu Blockierungen kommen kann, sind entsprechende Schutzelemente wie hydraulische Kupplungen, Kupplungen, Rutschkupplungen usw. zu installieren.
- b) Beim Lackieren die bearbeiteten Flächen und die Dichtringe schützen, damit der Anstrichstoff nicht dem Kunststoff angreift und somit die Dichtigkeit der Ölabdichtungen in Frage gestellt wird.
- c) Die Organe, die mit einer Keilverbindung auf der Abtriebswelle des Getriebes befestigt werden, müssen mit einer Toleranz ISO H7 gearbeitet sein, um allzu fest blockierte Verbindungen zu vermeiden, die eventuell zu einer irreparablen Beschädigung des Getriebes während des Einbaus führen könnten. Außerdem sind beim Ein- und Ausbau dieser Organe geeignete Zugstangen und Abzieher zu verwenden, wobei die Gewindebohrung an den Köpfen der Wellen zu verwenden ist.
- d) Die Berührungsflächen müssen sauber sein und vor der Montage mit einem geeigneten Schutzmittel behandelt

13 - INSTALLATION

Il est très important, pour l'installation du réducteur, de se conformer aux règles suivantes :

- a) *S'assurer que la fixation du réducteur soit stable afin d'éviter toute vibration.*
- Installer (en cas de chocs, de surcharges prolongées ou de blocages) des coupleurs hydrauliques, des embrayages, des limiteurs de couple etc...*
- b) *En phase de peinture, il faudra protéger les plans usinés et le bord extérieur des bagues d'étanchéité pour éviter que la peinture ne dessèche le caoutchouc, ce qui risque de nuire à l'efficacité du joint.*
- c) *Les organes qui sont calés sur les arbres de sortie du réducteur doivent être réalisés avec une tolérance ISO H7 pour éviter les accouplements trop serrés qui, en phase de montage, pourraient endommager irrémédiablement le réducteur.*
- En outre, pour le montage et le démontage de ces organes, nous conseillons d'utiliser un outillage et des extracteurs appropriés en utilisant le trou taraudé situé en extrémité d'arbre.*
- d) *Les surfaces de contact devront être propres et traitées avec des produits de protections appropriés*



l'ossidazione e il conseguente bloccaggio delle parti.	<i>oxidation and, as a result, seizure of parts.</i>	werden, um Oxidierung und die daraus folgende Blockierung der Teile zu verhindern.	<i>avant le montage afin d'éviter l'oxydation et par suite le blocage des pièces.</i>
e) Prima della messa in servizio del riduttore accertarsi che la macchina che lo incorpora sia in regola con le disposizioni della Direttiva Macchine 2006/42/CE e successivi aggiornamenti.	e) <i>Prior to putting the gear unit into operation make sure that the equipment that incorporates the same complies with the current revision of the Machines Directive 2006/42/EC.</i>	e) Bevor das Getriebe im Betrieb zu setzen, muß man sich vergewissern daß die das Getriebe einbauende Maschine gemäß den aktuellen Regelungen der Maschinen Richtlinie 2006/42/EG ist.	e) <i>Avant la mise en service du réducteur, vérifier que la machine où il est monté est conforme aux normes de la Directive Machines 2006/42/CE et ses mises à jour.</i>
f) Prima della messa in funzione della macchina, accertarsi che la posizione del livello del lubrificante sia conforme alla posizione di montaggio del riduttore e che la viscosità sia adeguata (vedi tabella B3).	f) <i>Before starting up the machine, make sure that oil level conforms to the mounting position specified for the gear unit and the viscosity is adequate (see table B3).</i>	f) Vor Inbetriebnahme der Maschine sicherstellen, daß die Anordnung der Füllstandschraube der Einbaulage angemessen ist, und die Viskosität des Schmiermittels entspricht (siehe Tabelle B3).	f) <i>Avant la mise en marche de la machine, s'assurer que la position du niveau du lubrifiant soit conforme à la position de montage du réducteur et que la viscosité soit appropriée (voir tableau B3).</i>
g) Nel caso di installazione all'aperto prevedere adeguate protezioni e/o carterature allo scopo di evitare l'esposizione diretta agli agenti atmosferici e alla radiazione solare.	g) <i>For outdoor installation provide adequate guards in order to protect the drive from rainfalls as well as direct sun radiation.</i>	g) Bei Inbetriebnahme in Frein, muß man geeigneten Schutzgeräte vorsehen, um das Antrieb gegen Regen und direkte Sonnenstrahlung zu schützen.	g) <i>En cas d'installation en plein air, il est nécessaire d'appliquer des protections et/ou des caches appropriés de façon à éviter l'exposition directe aux agents atmosphériques et aux rayonnements solaires.</i>

Assemblaggio del servomotore mediante morsetto calettatore (ingresso tipo SC)

Ruotare il morsetto di serraggio fino ad allineare il suo intaglio in corrispondenza di quelli che sono ricavati sull'albero di ingresso del riduttore.

Se l'albero motore è dotato di chiavetta, questa va rimossa e la relativa cava deve pure trovarsi allineata sullo stesso piano, disposta dalla stessa parte della vite del morsetto.

Dopo aver così orientato l'albero del motore, portare la flangia del motore a battuta sulla flangia del riduttore e serrare le relative viti di fissaggio. Inserire infine una chiave dinamometrica attraverso il foro ricavato sulla faccia laterale della flangia e serrare la vite del morsetto con la coppia specificata nelle tavole dimensionali.

Fitting servomotors to gear heads featuring a clamping device (adapter type SC)

Turn the clamping device until its slot is aligned to those that are milled on the reducer input shaft. If the motor shaft features a key, this must be removed and the relevant keyway must also be aligned with the slots of clamping device and gear head input shaft, prior to inserting the servomotor into site. The keyway must be sitting on the same side as the locking screw. Tighten the bolts that hold the servomotor to the gear head, insert a torque wrench through the hole on the side of the flange and tighten the locking screw of the clamping device to the torque that is specified in the drawing section for the given adapter.

Zur Montage eines Servomotors wird eine Klemmvorrichtung benötigt (Eingangsadapter Typ SC)

Klemmvorrichtung drehen bis die Markierung mit der Markierung der Eingangswelle übereinstimmt.

Wenn die Motorwelle eine Passfeder hat, muss diese entfernt werden und die Passfedernut so gedreht werden, dass sie mit der Markierung der Eingangswelle fluchtet, erst dann kann der Motor montiert werden. Die Nut muss sich auf der gleichen Seite wie die Schraube befinden.

Drehen Sie die Schrauben, die den Servomotoren halten, an. Stecken Sie einen Drehmomentschlüssel durch die seitliche Bohrung im Flansch und drehen Sie die Schrauben in der Klemmvorrichtung mit dem für den Adapter vorgeschriebenen Moment (siehe Zeichnung) fest.

Assemblage du servomoteur avec le frette de serrage (entrée type SC)

Tourner la frette de serrage jusqu'à aligner sa fente en correspondance de celles présentes sur l'arbre d'entrée du réducteur.

Si l'arbre moteur est muni d'une clavette, celle-ci doit être retirée et son logement doit être lui aussi aligné sur le même plan, disposé du même côté de la vis de la frette.

Accoster ensuite la bride du moteur à la bride du réducteur et serrer les vis de fixation.

Serrer la vis de la frette en utilisant une clé dynamométrique introduite dans le trou présent sur la face latérale de la bride. Les couples de serrage sont spécifiés dans les pages des dimensions de chaque réducteur.



14 - ISTRUZIONI DI INSTALLAZIONE

Negli schemi indicati in tabella (A8) vengono riportati i 3 casi possibili per l'installazione dei riduttori tipo A sulla struttura della macchina da operare. Per ognuno di questi casi riportiamo nella tabella (A9) le dimensioni delle viti a testa esagonale da utilizzare. Inoltre, per una facile installazione, suggeriamo di utilizzare il tipo di chiave mostrato in tabella (A8).

14 - INSTALLATION INSTRUCTIONS

Schemes in table (A8) show the 3 possible installation patterns for A gear units to the machine frame. For each of these circumstances, table (A9) indicates hexagonal head screw sizes to be used. Besides, to facilitate the installation, we suggest to use a wrench of the type shown in table (A8).

14 - ANBAUANWEISUNGEN

In den auf die Tabelle (A8) angegebenen Bilder werden die 3 möglichen Fällen zum Anbau des Getriebes Typ A der zu betriebsenden Maschine dargestellt. Für jede dieser Fällen sind auf die Tabelle (A9) die Abmessungen der zu verwendenden Sechskanteschraube angegeben. Im übrigen, für ein einfaches Anbau, schlagen wir vor, den Schlüsseltyp wie auf die Tabelle (A8) zu verwenden.

14 - INSTRUCTIONS POUR L'INSTALLATION

Dans les schémas indiqués dans le tableau (A8) l'on a indiqué 3 cas possibles pour le montage des réducteurs type A à la structure de la machine. Pour tous ces cas l'on doit se référer pour les dimensions des vis à tête hexagonales à employer, au tableau (A9). Pour un montage plus soigneux nous conseillons l'emploi du type de clé indiquée au tableau (A8).

(A8)

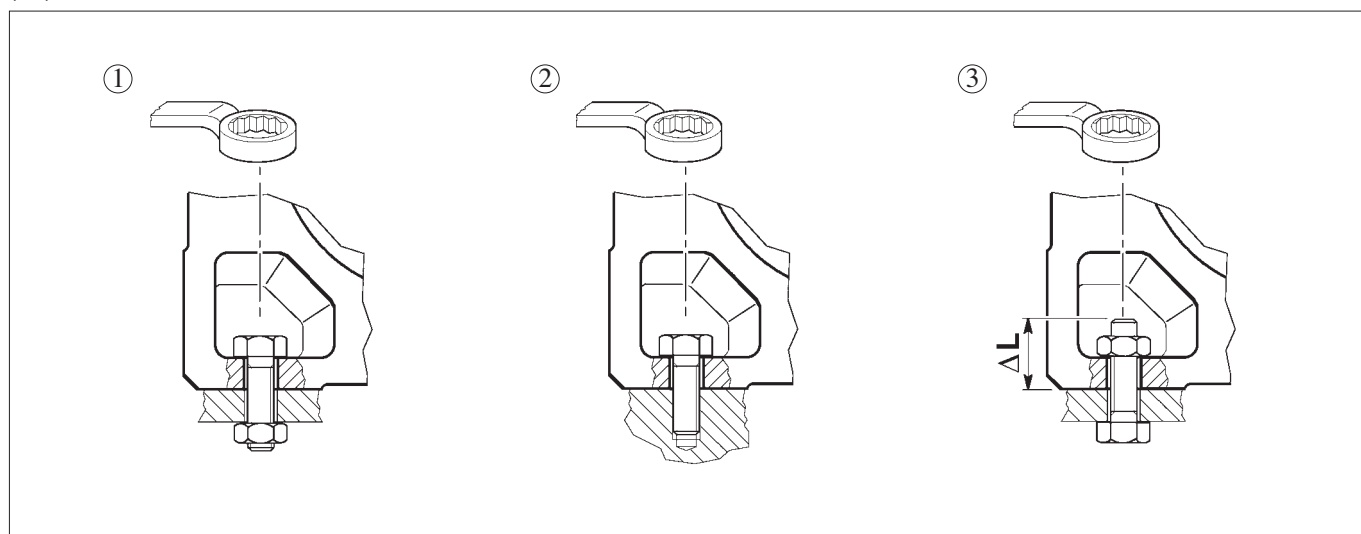

(A9)

	Tipo vite / Bolt type / Schraubentyp / Type de vis			
	①	②	③	ΔL (mm)
A 05	M8x22	M8x20	M8x ...	22
A 10	M8x25	M8x20	M8x ...	20
A 20	M8x25	M8x20	M8x ...	20
A 30	M10x30	M10x25	M10x ...	25
A 35	M10x30	M10x25	M10x ...	25
A 41	M12x35	M12x30	M12x ...	30

	Tipo vite / Bolt type / Schraubentyp / Type de vis			
	①	②	③	ΔL (mm)
A 50	M14x45	M14x40	M14x ...	35
A 55	M14x40	M14x40	M14x ...	35
A 60	M16x50	M16x45	M16x ...	40
A 70	M20x60	M20x55	M20x ...	45
A 80	M24x70	M24x65	M24x ...	55
A 90	M24x90	M24x80	M24x ...	65



**15 - ISTRUZIONI
PER IL SERRAGGIO
DEL CALETTATORE**

I riduttori serie A 05 ... A 90 sono disponibili a richiesta con albero lento cavo munito di calettatore (forma costruttiva US). È necessario eseguire le seguenti operazioni per effettuare il montaggio del riduttore sull'albero della macchina da azionare.

- 1) Svitare le viti di bloccaggio gradualmente e in successione rimuovendo il calettatore.
- 2) Pulire e sgrassare accuratamente le zone di accoppiamento fra albero lento riduttore e albero della macchina da azionare.
- 3) Accoppiare albero condotto e riduttore.
- 4) Montare il calettatore sull'albero del riduttore.
- 5) Avvitare a fondo tutte le viti del calettatore gradualmente e in successione facendo uso di una chiave dinamometrica.

È necessario ripetere la sequenza alcune volte al fine di raggiungere la coppia di serraggio Mt indicata in tabella (A10).

! Attenzione! Non usare bisolfuro di molibdeno o altri grassi, causa di notevoli riduzioni del coefficiente d'attrito.

**15 - INSTRUCTIONS FOR
FITTING OF SHRINK DISC**

Gearboxes of the A 05 ... A 90 series are available upon request with hollow output shaft complete with shrink disc (US version). To fit the gearbox onto the customer shaft the procedure described here below must be followed.

- 1) *Unscrew the locking bolts progressively and remove the shrink disc.*
- 2) *Carefully clean and degrease mating surfaces of the hollow shaft and customer shaft.*
- 3) *Fit the gearbox onto the driven shaft.*
- 4) *Fit the shrink disc onto the gearbox shaft.*
- 5) *Tighten all locking bolts of the shrink disc gradually and progressively in circular sequence using a torque wrench.*

Several sequences are necessary until the specified tightening torque Mt is reached. See tab. (A10) for reference.

! Warning! Do not use molybdenum disulfide or any grease whatsoever because of consequent reduction in the friction coefficient.

**15 - ANLEITUNGEN
FÜR DEN ANZUG DER
SCHRUMPFSCHEIBE**

Die Getriebe der Serie A 05 ... A 90 sind auf Anfrage mit einer Abtriebswelle verfügbar, die mit einer Schrumpfscheibe versehen ist (Version US). Um ein solches Getriebe auf die Welle der zu betreibenden Maschine montieren zu können, muß man folgendermaßen vorgehen:

- 1) Die Befestigungsschrauben schrittweise und in entsprechender Reihenfolge lockern und so die Schrumpfscheibe entfernen.
- 2) Die Passbereiche zwischen Abtriebswelle des Getriebes und der Welle der anzutreibenden Maschine säubern und entfetten.
- 3) Die geführte Welle und das Getriebe aneinander passen.
- 4) Die Schrumpfscheibe auf die Getriebewelle montieren.
- 5) Alle Schrauben der Verbindung schrittweise und nacheinander mit einem Drehmomentenschlüssel anschrauben.

Diese Sequenz ist mehrmals zu wiederholen, d.h. solange bis der in der Tabelle (A10) angegebene Azugs-momet Mt erreicht wurde.

! Achtung! Niemals Molybdändisulfid oder andere Fettarten verwenden, da sie zu erheblichen Reduzierungen des Reibkoeffizienten führen würden.

**15 - INSTRUCTIONS
POUR LE BLOCCAGE DE
LA FRETTE DE SERRAGE**

Les réducteurs série A 05 ... A 90 sont disponibles sur demande avec un arbre de sortie creux équipé de frette de serrage (version US). Il est nécessaire d'exécuter les opérations suivantes pour effectuer le montage du réducteur sur l'arbre de la machine à actionner :

- 1) *Dévisser graduellement et l'une après l'autre les vis de blocage et enlever la frette de serrage.*
- 2) *Nettoyer et dégraisser soigneusement les zones d'accouplement entre arbre de sortie réducteur et arbre de la machine à actionner.*
- 3) *Accoupler l'arbre mené et le réducteur.*
- 4) *Monter la frette de serrage sur l'arbre réducteur.*
- 5) *Visser à fond graduellement et l'une après l'autre toutes les vis de la frette de serrage à l'aide d'une clé dynamométrique.*

Il est nécessaire de répéter la séquence plusieurs fois afin d'atteindre le couple de serrage Mt indiqué dans le tableau (A10).

! Attention! Ne pas utiliser de bisulfure de molybdène ou autres graisses, susceptibles de provoquer d'importantes réductions du coefficient de frottement.

(A10)

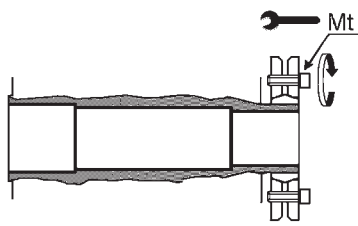

	A 05	A 10	A 20	A 30	A 35	A 41	A 50	A 55	A 60	A 70	A 80	A 90
Mt [Nm]	14.5	14.5	14.5	14.5	14.5	14.5	35	35	35	35	69	69



16 - ISTRUZIONI PER MONTAGGIO BOCCOLE DI ADATTAMENTO - QF

16 - MOUNTING INSTRUCTIONS FOR ADAPTER BUSHINGS - QF

16 - MONTAGEANLEITUNG FÜR ADAPTERBUCHSEN - QF

16 - INSTRUCTIONS POUR LE MONTAGE DES DOUILLES D'ADAPTATION - QF

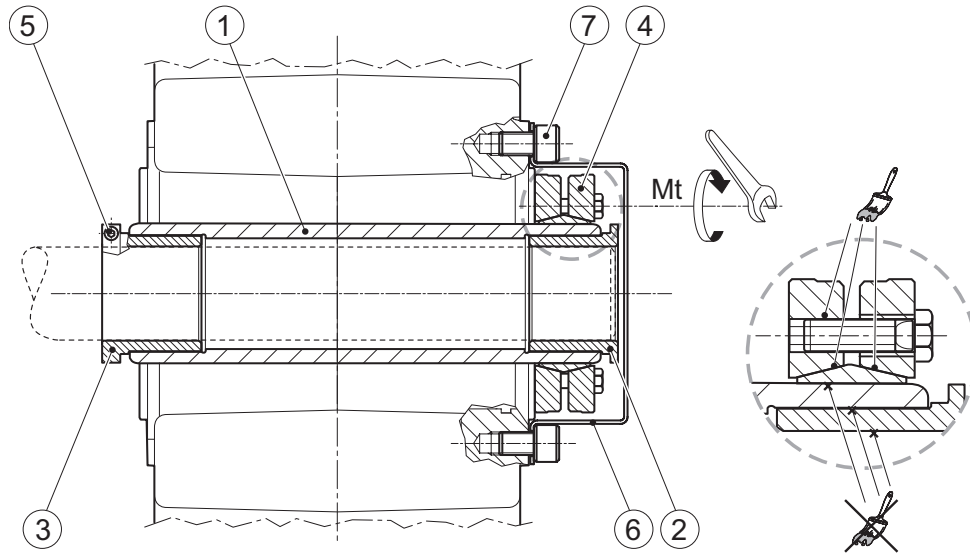

Sequenza di montaggio

- a) Pulire e sgrassare accuratamente le superfici di contatto dell'albero macchina, dell'albero del riduttore (1), della boccia elastica (2) e di arresto assiale (3) e del giunto calettatore (4), dopo averlo rimosso dal mozzo su cui si trova calettato.

! Su queste superfici non usare bisolfuro di molibdeno, o qualsiasi altro tipo di grasso, che ridurrebbe notevolmente il coefficiente d'attrito nella zona di contatto e comprometterebbe la funzionalità del giunto calettatore.

- b) Inserire la boccia di arresto assiale (3) dotata di morsetto di serraggio nella sede ricavata nell'albero del riduttore dal lato caratterizzato dalla sporgenza minore dell'albero stesso.
- c) Inserire il riduttore completo della boccia di arresto sull'albero da comandare e farlo scorrere assialmente fino a raggiungere la posizione voluta.
- d) Inserire ora la boccia elastica (2) sull'albero da comandare e portarla ad impegnarsi nella sede ricavata nell'albero cavo del riduttore.
- e) Serrare la vite (5) presente sul collare della boccia di arresto (3) con una coppia M_t pari a 6 Nm.
- f) Allentare le viti del giunto calettatore e inserirlo sulla sporgenza dell'albero lento del riduttore, serrare poi nuovamente le viti senza forzar-

Fitting sequence

- a) *Thoroughly clean and degrease the contact surfaces of the machine shaft and the hollow shaft of the gearbox (1), as well as of clamp (2) and support bushings (3) and shrink disc (4) after this has been removed from the hub it is fitted onto.*

! *On these surfaces do not use molybdenum disulfide or any other grease which would affect the friction coefficient of the coupling surfaces and reduce the performance of the shrink disc.*

- b) *Insert the support bushing (3) into bore machined in the hub of the gearbox*
- c) *Fit gearbox complete with support bushing onto machine' driven shaft and slide it to its desired position.*
- d) *Slide clamp bushing onto machine' shaft all the way until it sits into site bored into gearbox's hub.*
- e) *Tighten the screw (5) of support bushing with a torque $M_t = 6 \text{ Nm}$, until it locks firmly onto machine shaft.*
- f) *Loosen screws of shrink disc and fit it onto outer diameter of gearbox hub, then tighten back again the screws with medium force to help the shrink disc bed in onto gearbox hub.*
- g) *Through a torque wrench tighten all screws of the shrink disc progressively and in circular sequence to the torque specified here after.*

Montage

- a) Die Kontaktflächen der Maschinenwelle, der Getriebewelle (1), der Spannbuchse (2), der Klemmbuchse (3) und der Schrumpfscheibe (4) sorgfältig reinigen und entfetten.

! Auf diesen Flächen kein Molybdaensulfid oder andere Fettarten einsetzen, die den Reibungskoeffizienten im Kontaktbereich deutlich verringern und die Funktionalität der Schrumpfungsbinding beeinträchtigen könnten.

- b) Die Klemmbuchse (3) auf der Seite ohne Schrumpfscheibe in die Getriebewelle einstecken.
- c) Das Getriebe mit der Maschinenwelle und der montierten Klemmbuchse montieren und axial bis zum Erreichen der gewünschten Position verschieben.
- d) Anschließend die Spannbuchse (2) auf die Maschinenwelle schieben und im eingelassenen Sitz der Getriebehohlwelle arretieren.
- e) Die Schraube (5) am Bund der Klemmbuchse (3) mit einem Anzugsmoment M_t von 6 Nm festziehen.
- f) Die Schrauben der Schrumpfscheibe lösen und die Schrumpfscheibe am überstehenden Teil der Abtriebswelle des Getriebes montieren. Anschließend die Schrauben wieder leicht anziehen und sicherstellen, dass die Schrumpfscheibe sich nicht verkantet hat.

Séquence de montage

- a) *Nettoyer et dégraisser soigneusement les surfaces de contact de l'arbre machine, de l'arbre réducteur (1), de la douille élastique (2), de la douille d'arrêt axial (3) et de la frette (4), après avoir enlevé cette dernière sur le moyeu sur lequel elle se trouve.*

! *Sur ces surfaces il est déconseillé d'utiliser du bisulfure de molybdène ou tout autre type de graisse qui pourrait réduire considérablement le coefficient de frottement dans la zone de contact et compromettre le fonctionnement de la frette de serrage.*

- b) *Introduire la douille d'arrêt axial (3), équipée d'une bague de serrage, dans le logement réalisé dans l'arbre réducteur du côté dépassant le moins.*
- c) *Introduire le réducteur, ainsi équipé, sur l'arbre machine et le faire glisser axialement jusqu'à atteindre la position souhaitée.*
- d) *Introduire maintenant la douille élastique (2) sur l'arbre machine, jusqu'à l'épaulement réalisé dans le logement de l'arbre creux du réducteur.*
- e) *Serrer la vis (5) du collier de la bague de serrage, de la douille d'arrêt axial (3), avec un couple M_t de 6 Nm.*
- f) *Desserrer les vis de la frette et introduire celle-ci sur l'extrémité de l'arbre lent du réducteur, puis serrer légèrement les vis en vérifiant*



le accertandosi che il giunto sia allineato con il mozzo.

- g) Facendo uso di una chiave dinamometrica serrare adesso tutte le viti del calettatore con uguale forza e in successione circolare.

È opportuno giungere al valore finale della coppia dopo tre sequenze successive di serraggio delle viti. Rispettare le coppie di serraggio specificate in tabella.

It is best to reach the final torque value at the end of three stages of gradual tightening. Respect the tightening torque values specified in the table.

- g) Unter Verwendung eines Drehmomentschlüssels alle Schrauben der Schrumpfscheibe gleichmäßig der Reihe nach festziehen.

Der endgültige Wert des Anzugsmoments sollte nach drei aufeinander folgenden Durchgängen des Anzugs der Schrauben erreicht werden. Die in der Tabelle genannten Anzugsmomente berücksichtigen.

que la frette soit alignée avec le moyeu.

- g) A l'aide d'une clé dynamométrique, serrer maintenant toutes les vis de la frette, successivement avec le même couple et dans un ordre circulaire.

Il faut atteindre la valeur finale de couple après trois séquences consécutives de serrage des vis. Respecter les couples de serrage spécifiés dans le tableau.

(A11)

	A 10, A 20	A 30	A 35, A 41, A 50	A 55, A 60
Mt	10 Nm	5.2 Nm	12 Nm	30 Nm

- h) Montare infine il carter di protezione (6) e serrare le viti (7).

- h) Finally fit the safety guard (6) and secure it with screws (7).

- h) Zum Abschluss die Schutzhaube (6) montieren und die Schrauben (7) festziehen.

- h) Compléter le montage en installant le capot de protection (6) et en serrant les vis (7).

Sequenza di smontaggio

- a) Rimuovere il carter di protezione e successivamente allentare tutte le viti del calettatore progressivamente e in successione. Non rimuovere del tutto le viti dalla loro sede!
b) Allentata la tensione di serraggio, il riduttore può essere rimosso facendolo scorrere sull'albero macchina cliente.

Removal sequence

- a) Remove safety guard and loosen screws of the shrink disc progressively and in circular sequence. Do not remove completely the screws from site!
b) Once the locking pressure is relieved the gearbox will slide freely onto machine shaft and it can be removed.

Demontagesequenz

- a) Die Schutzhaube abnehmen und anschließend alle Schrauben der Schrumpfscheibe gleichmäßig der Reihe nach in mehreren Umläufen lösen. Die Schrauben dürfen nicht vollständig herausgedreht werden!
b) Nach dem Spannungskräfteabbau kann das Getriebe auf der Kunden-Maschinewelle verschoben und somit entnommen werden.

Séquence de démontage

- a) Ôter le capot de protection et ensuite desserrer progressivement toutes les vis de la frette dans un ordre circulaire. Ne pas enlever complètement les vis de leurs logements!
b) Une fois les vis desserrées, le réducteur peut être déplacé en le faisant glisser sur l'arbre machine.

ATTENZIONE! Giunti calettatore sporchi o usati devono essere completamente smontati prima del loro successivo rimontaggio, puliti da qualsiasi residuo con un prodotto diluente, e successivamente ingrassati con pasta al bisolfuro di molibdeno. La pasta lubrificante deve essere applicata in piccola quantità sulle superfici coniche del giunto e sulla filettatura di ognuna delle viti di serraggio (vedere dettaglio).

WARNING! Shrink discs that have collected dirt or have been long time in operation must be disassembled and thoroughly cleaned with a thinner prior to be put back again into use. Foreign particles must be removed and a small quantity of lubricant molybdenum bisulphide paste must be applied on both the tapered contact surfaces of the coupling and the threads of each of the tightening screws (see detail).

ACHTUNG! Verschmutzte oder gebrauchte Schrumpfscheiben müssen vor dem nachfolgenden Wiedereinbau vollständig ausgebaut werden, müssen mit einem auflösenden Produkt reinigen sein, um sie einwandfrei zu können und anschließend mit der Molybdänsulfid Schmierpaste zu schmieren. Die Schmierpaste ist in kleinen Mengen an den kegelförmigen Oberflächen der Verbindung und am Gewinde jeder Befestigungsschraube aufzutragen (siehe detail). Die Federbuchse ist nach dem Ausbau wieder einsetzbar. Immer prüfen, dass keine Deformierungen, Schläge, Oxidierungen oder Abnutzung vorhanden sind. Ist dies der Fall, muss die Buchse durch eine original-Ersatzbuchse ersetzt werden. Für die Reibverbindung ist dagegen nach jeweils drei Ausbau-/Wartungseingriffen neue Molybdänsulfid Schmierpaste am Gewinde der Schrauben und an den kegelförmigen Oberflächen aufzutragen. Die Schrauben müssen nach 3 Zyklus, Montage und Demontage, mit neuen Schrauben ersetzt sein. Auf jeden Fall ist für die vollständige Montagesequenz der vorherige Abschnitt einzusehen.

ATTENTION ! Des frettes sales ou déjà utilisées doivent être complètement démontées avant qu'elles ne soient utilisées à nouveau, afin d'être nettoyées de tous résidus avec un produit diluant, puis lubrifiées à l'aide de pâte au bisulfure de molybdène.

La boccia elastica, se rimossa, è riutilizzabile, controllando che non siano presenti deformazioni, intaccature, tracce di ossidazione o usura. In questi casi la boccia va sostituita con altra di tipo originale. Dopo tre cicli di montaggio/smontaggio il giunto d'attrito richiede l'applicazione di nuova pasta al bisolfuro di molibdeno sulle superfici coniche e la sostituzione delle viti con altre di tipo nuovo e di pari classe, anche queste pre-trattate con la stessa pasta lubrificante.

The elastic bush can be removed and re-used. Check it for deformation, notches, oxidation and wear before reusing it, however. Replace it with an original spare part if any damage or wear is detected. After three mounting cycles it is recommended to apply fresh new molybdenum bisulphide paste on the tapered surfaces of the shrink disc and to replace the screws with new ones of the same class, also coated with same fresh lubricant paste.

La pâte lubrifiante doit être appliquée en petite quantité sur les surfaces coniques de la frette et sur le filetage de chacune des vis (voir le détail). Éviter les excédents.

Ad ogni modo, per la sequenza di montaggio completa riferirsi al paragrafo precedente.

However, for the complete fitting sequence refer to previous paragraph.

La bague élastique, une fois enlevée, peut être réutilisée, en vérifiant l'absence de déformations, entailles, traces d'oxydation ou usure. Dans ces cas, remplacer la bague par une d'origine. Toutes les trois opérations de démontage et/ou maintenance, la frette demande par contre une nouvelle application de pâte au bisulfure de molybdène sur les surfaces coniques et le remplacement des vis par de nouvelles sur lesquelles il faudra également appliquer la même pâte.

Toutefois, pour la séquence de montage complet se référer au paragraphe précédent.

**17 - STOCCAGGIO**

Il corretto stoccaggio dei prodotti ricevuti richiede l'esecuzione delle seguenti attività:

- a) Escludere aree all'aperto, zone esposte alle intemperie o con eccessiva umidità.
- b) Interporre sempre tra il pavimento ed i prodotti, piane lignee o di altra natura, atti ad impedire il diretto contatto col suolo.
- c) Per periodi di stoccaggio e soste prolungate le superfici interessate agli accoppiamenti quali flange, alberi e giunti devono essere protette con idoneo prodotto antiossidante (Mobilarna 248 o equivalente). In questo caso i riduttori dovranno essere posizionati con il tappo di sfriato nella posizione più alta e riempiti interamente d'olio. Prima della loro messa in servizio nei riduttori dovrà essere ripristinata la corretta quantità, e il tipo di lubrificante.

17 - STORAGE

Observe the following instructions to ensure correct storage of the products:

- a) *Do not store outdoors, in areas exposed to weather or with excessive humidity.*
- b) *Always place boards, wood or other material between the products and the floor. The gearboxes should not have direct contact with the floor.*
- c) *In case of long-term storage all machined surfaces such as flanges, shafts and couplings must be coated with a suitable rust inhibiting product (Mobilarna 248 or equivalent). Furthermore gear units must be placed with the fill plug in the highest position and filled up with oil. Before putting the units into operation the appropriate quantity, and type, of oil must be restored.*

17 - LAGERUNG

Die korrekte Lagerung der Antriebe erfordert folgende Vorkehrungen:

- a) Die Produkte nicht im Freien lagern und nicht in Räumen, die der Witterung ausgesetzt sind, oder eine hohe Feuchtigkeit aufweisen.
- b) Die Produkte nie direkt auf dem Boden, sondern auf Unterlagen aus Holz oder einem anderen Material lagern.
- c) Bei anhaltenden Lager- und Haltszeiten müssen die Oberflächen für die Verbindung, wie Flansche, Wellen oder Kupplungen mit einem geeigneten Oxidationsschutzmittel behandelt werden (Mobilarna 248 oder ein äquivalentes Mittel). Übrigens müssen die Getriebe mit nach oben gerichteter Entlüftungsschraube gelagert und mit Öl gefüllt werden. Die Getriebe müssen vor ihrer Verwendung mit der angegebenen Menge des vorgesehenen Schmiermittels gefüllt werden.

17 - STOCKAGE

Un correct stockage des produits reçus nécessite de respecter les règles suivantes :

- a) *Exclure les zones à ciel ouvert, les zones exposées aux intempéries ou avec humidité excessive.*
- b) *Interposer dans tous les cas entre le plancher et les produits des planches de bois ou des supports d'autre nature empêchant le contact direct avec le sol.*
- c) *Pour une stockage de long durée il faut protéger les surfaces d'accouplement (brides, arbres, manchon d'accouplement) avec produit anti oxydant (Mobilarna 248 ou équivalent). Dans ce cas les réducteurs devront être placés avec bouchon reniflard vers le haut et complètement rempli d'huile. Avant de la mise en service du réducteur, la bon quantité d'huile devra être rétabli selon la quantité indiquée sur le catalogue.*

18 - CONDIZIONI DI FORNITURA

I riduttori vengono forniti come segue:

- a) già predisposti per essere installati nella posizione di montaggio come definito in fase di ordine;
- b) collaudati secondo specifiche interne;
- c) le superfici di accoppiamento non sono verniciate;
- d) provvisti di dadi e bulloni per montaggio motori per la versione IEC;
- e) dotati di protezioni in plastica sugli alberi;
- f) provvisti di golfare di sollevamento (dove previsto).

18 - CONDITIONS OF SUPPLY

Gear units are supplied as follows:

- a) *configured for installation in the mounting position specified when ordering;*
- b) *tested to manufacturer specifications;*
- c) *mating machined surfaces come unpainted;*
- d) *nuts and bolts for mounting motors are provided;*
- e) *shafts are protected during transportation by plastic caps;*
- f) *supplied with lifting lug (where applicable).*

18 - LIEFERBEDINGUNGEN

Die Getriebe werden in folgendem Zustand geliefert:

- a) schon bereit für die Montage in der bei Bestellung festgelegten Einbaulage;
- b) nach werksinternen Spezifikationen geprüft;
- c) die Verbindungsflächen sind nicht lackiert;
- d) ausgestattet mit Schrauben und Muttern für die Montage der Motoren (Version mit Adapter für IEC-Motoren);
- e) alle Getriebe werden mit Kunststoffschutz auf den Wellen geliefert;
- f) mit Transportriering zum Anheben (falls vorgesehen).

18 - CONDITIONS DE LIVRAISON

Les réducteurs sont livrés comme suit :

- a) *déjà prédisposés pour être installés dans la position de montage comme défini en phase de commande ;*
- b) *testés selon les spécifications internes ;*
- c) *les surfaces de liaison ne sont pas peintes ;*
- d) *équipés d'écrous et de boulons pour le montage des moteurs normalisés pour la version IEC ;*
- e) *embouts de protections en plastique sur les arbres ;*
- f) *dotés d'un crochet de levage (quand cela est prévu).*

19 - SPECIFICHE DELLA VERNICE

Le specifiche della vernice applicata sui riduttori (dove previsto) potranno essere richieste alle filiali o ai distributori che hanno fornito i gruppi.

19 - PAINT SPECIFICATIONS

Specifications for paint applied to gearboxes (where applicable) may be obtained from the branches or dealers that supplied the units.

19 - ANGABEN ZU DEN ANSTRICHSTOFFE

Die Spezifikationen des Lackes, der auf den Getriebe (wo erforderlich) verwendet wurde, können bei den Filialen oder Verkaufsstellen, die die Gruppen geliefert haben, angefordert werden.

19 - SPECIFICATIONS DE LA PEINTURE

Les spécification de la peinture appliquée sur les réducteurs pourront, le cas échéant, être demandées aux filiales ou aux distributeurs ayant fourni les groupes.

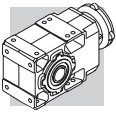

20 - CARATTERISTICHE COSTRUTTIVE

Le caratteristiche costruttive salienti sono:

- modularità
- compattezza
- montaggi universali
- rendimenti elevati
- basso livello di rumorosità
- ingranaggi in acciaio legato cementati e temprati
- casse in alluminio non verniciate nelle grandezze 05, 10, 20, 30, casse in ghisa ad alta resistenza, verniciate, nelle altre grandezze
- alberi in entrata e uscita in acciaio ad alta resistenza.

20 - DESIGN FEATURES

The main design characteristics are:

- modularity
- space effective
- universal mounting
- high efficiency
- quiet operation
- gears in hardened and case-hardened steel
- bare aluminium housing for sizes 05, 10, 20, 30, unpainted high strength painted cast-iron housings for larger frame sizes
- input and output shafts from high grade steel.

20 - KONSTRUKTIVE EIGENSCHAFTEN

Die wichtigsten konstruktiven Eigenschaften sind:

- Baueinheitensystem
- Kompaktheit
- universelle Montage
- hohe Wirkungsgrade
- niedriger Geräuschpegel
- einsatzgehärtete und gehärtete Zahnräder aus legiertem Stahl
- Nicht lackierten Aluminiumgehäuse bei den Größen 05, 10, 20 und 30; hochwiderstandsfähige und lackierte Gußgehäuse bei den anderen Größen
- Antriebs- und Abtriebswellen aus hochwiderstandsfähigem Stahl.

20 - CARACTERISTIQUES DE CONSTRUCTION

Les principales caractéristiques de construction sont :

- modularité
- compacité
- montages universels
- rendements élevés
- faible niveau de bruit
- engrenages en acier allié cémentés et trempés
- carters en aluminium non peints dans les tailles 05, 10, 20, 30, carters en fonte à haute résistance peints dans les autres tailles
- arbres d'entrée et de sortie en acier à haute résistance.

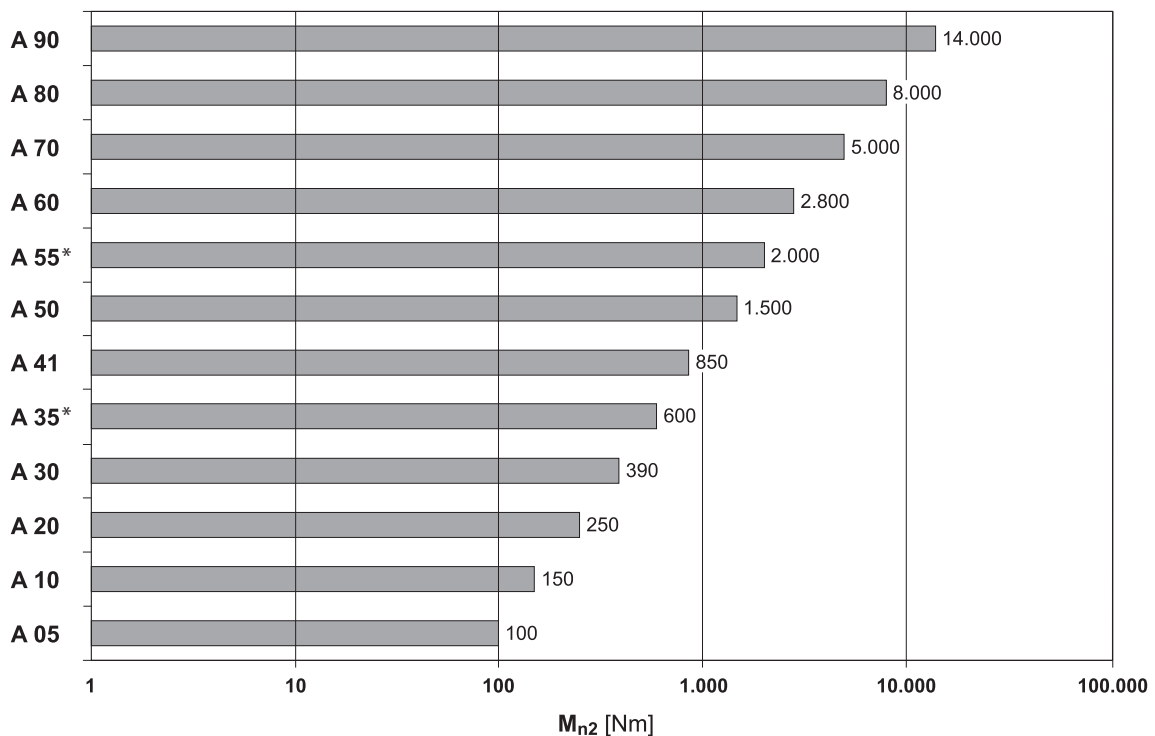

* Per eventuali limitazioni relative alla forma costruttiva QF vedere il capitolo "FORME COSTRUTTIVE".

* For any limitations regarding construction type QF see the "VERSIONS" chapter.

* Für eventuelle Begrenzungen bezüglich der Bauform QF siehe Kapitel "BAUFORMEN".

* Pour d'éventuelles limitations relatives à la forme de construction QF, voir le chapitre « FORMES DE CONSTRUCTION ».

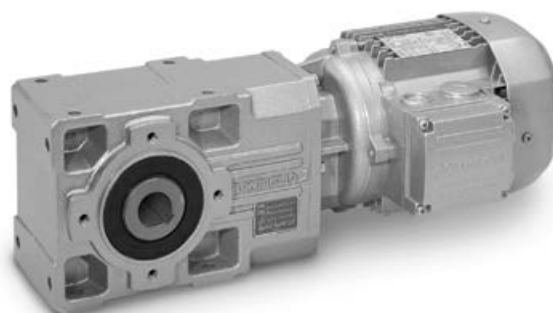

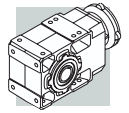

21 - FORME COSTRUTTIVE

21 - VERSIONS

21 - BAUFORMEN

21 - FORMES DE CONSTRUCTION

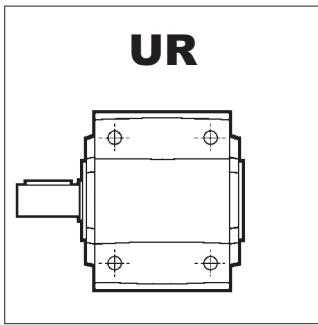

UR

Albero lento a singola sporgenza

Single extension output shaft

Einzelwellenende-Abtriebswelle

Arbre lent sortant d'un seul côté

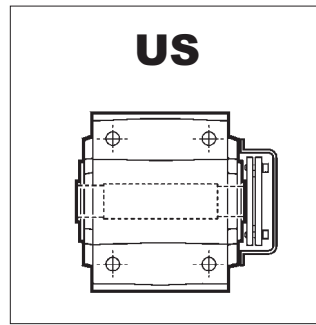

US

Albero lento cavo e calettatore

Hollow output shaft and shrink disc

Abtriebshohlwelle und Schrumpfscheibe

Arbre lent creux et frette de serrage

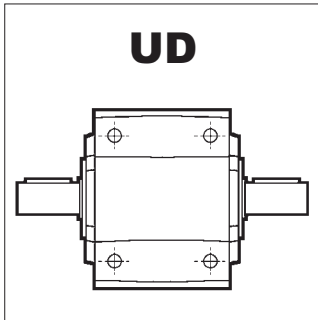

UD

Albero lento bisporgente

Double extended output shaft

Zweiwellenenden-Abtriebswelle

Arbre lent sortant de deux côtés

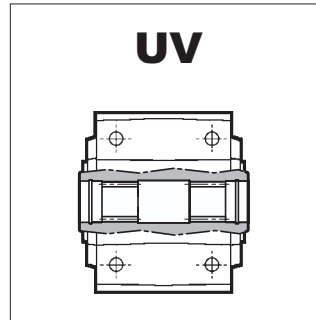

UV

Albero lento scanalato DIN 5480

Splined hollow shaft DIN 5480

Hohlwelle mit Vielkeilverzahnung DIN 5480

Arbre creux cannelé DIN 5480

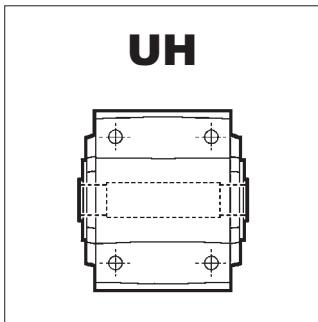

UH

Albero lento cavo con cava per linguetta

Hollow output shaft and keyway

Federnut-Abtriebshohlwelle

Arbre lent creux claveté

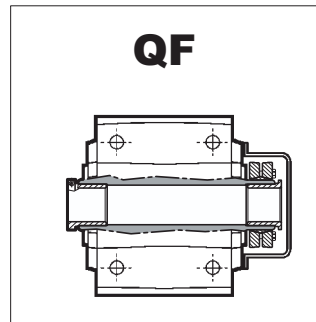

QF

Quick-fit

Albero con bocche di adattamento e giunto calettatore

Hollow shaft with adapter bushings and shrink disc

Hohlwelle mit Adapterbuchsen und Schrumpfscheibe

Arbre creux avec douilles d'adaptation et frette de serrage

M _{n2} max [Nm]	
A 35 QF35	550
A 55 QF55	1900

Forme costruttive con flangia riportata

Basic versions with bolted flange

Bauformen mit aufgesetztem Flansc

Formes de construction avec bride rapportée

Gli schemi riportati evidenziano le flange applicabili alle forme costruttive base e la loro collocazione (①,②).

The sketches show the applicable flanges to the basic versions and their positions, designated with either ① or ②.

Die angegebenen Bilder zeigen die den Grundbauformen anbaubaren Flansche und ihre Positionierung (①,②).

Les schémas reportés définissent les brides applicables aux formes de construction standard et leur position (①,②).

UR F1...

UR F2...

UD F1...

UD F2...

UH... F1...

UH... F2...

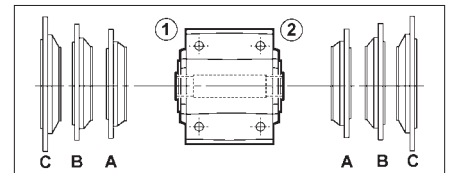
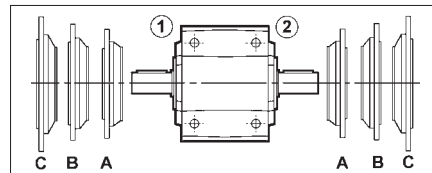
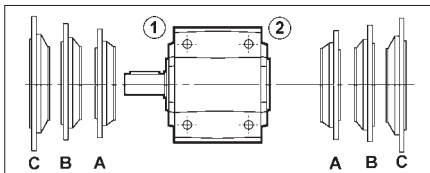

US F1...

US F2...

UV F1...

UV F2...

QF...

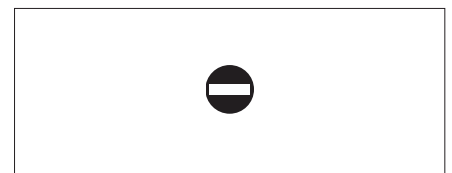
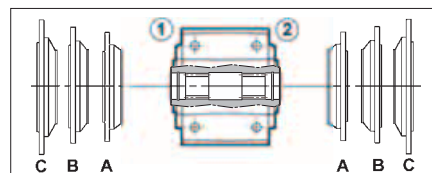
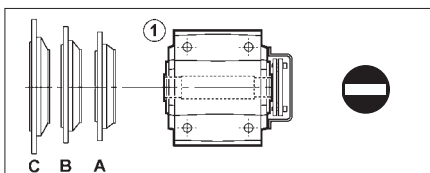

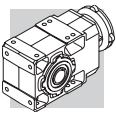

RIDUTTORE / GEAR UNIT / GETRIEBE / REDUCTEUR

A 35 2 UH40 F1A 33.2 S3 VA

OPZIONI / OPTIONS
OPTIONEN / OPTIONS

26

POSIZIONE DI MONTAGGIO / MOUNTING POSITION
EINBAULAGEN / POSITION DE MONTAGE

B3 (Standard), **B6, B7, B8, VA, VB**

31

DESIGNAZIONE INGRESSO / INPUT CONFIGURATION
BEZEICHNUNG DER ANTRIEBSSEITE / DESIGNATION ENTREE

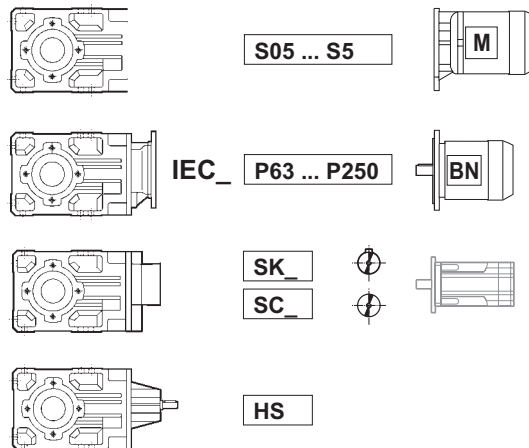

RAPPORTO DI RIDUZIONE / GEAR RATIO
ÜBERSETZUNG / RAPPORT DE REDUCTION

GRANDEZZA E POSIZIONE FLANGIA DI USCITA (specificare solo se richiesta)
OUTPUT FLANGE SIZE AND POSITION (specify only if requested)
BAUGRÖSSE UND LAGE DER ANTRIEBSFLANSCH (angeben nur wenn angefragt)
TAILLE ET POSITION BRIDE EN SORTIE (spécifier si elle est demandée)
F = Versione flangiata / Flanged version / Ausführung mit Flansch / Version avec bride
1,2 = Posizione flangia / Flange position / Flanschlage / Position bride
A,B,C = Grandezza flangia / Flange size / Flanschgröße / Taille bride

FORMA COSTRUTTIVA / VERSION / BAUFORM / FORME DE CONSTRUCTION

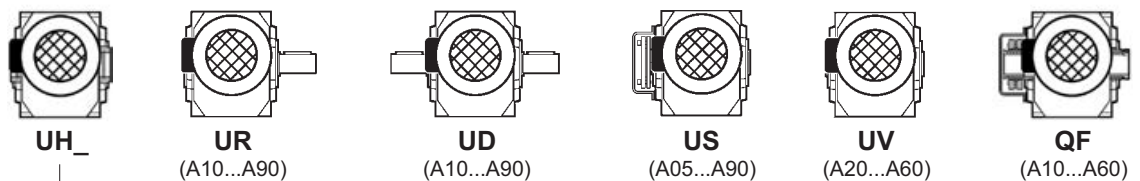

A 05	A 10	A 20	A 30	A 35	A 41	A 50	A 55	A 60	A 70	A 80	A 90
UH25	UH25	UH30	UH35	UH40	UH45	UH50	UH60	UH60	UH70	UH80	UH90
—	UH30	UH35	UH40	UH35	UH40	UH55	UH50	UH70	UH80	UH90	UH100

N° STADI DI RIDUZIONE / REDUCTIONS / GETRIEBESTUFEN / N.bre ETAGES DE REDUCTION
2 (A05...A60), **3** (A20...A90), **4** (A50...A90)

GRANDEZZA RIDUTTORE / GEAR FRAME SIZE / GETRIEBEBAUGRÖSSE / TAILLE REDUCTEUR
05, 10, 20, 30, 35, 41, 50, 55, 60, 70, 80, 90

TIPO / TYPE / TYP / TYPE
A

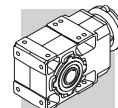

Designazione motore

Motor designation

Motor bezeichnung

Designation moteur

MOTORE / MOTOR / MOTOR / MOTEUR

FRENO / BRAKE / BREMSE / FREIN

M 3LA 4 230/400-50 IP54 CLF W FD 15 R SB 220 SA

OPZIONI
OPTIONS
OPTIONEN
OPTIONS

27

ALIMENTAZ. FRENO
BRAKE SUPPLY
BREMSVERSORGUNG
ALIMENTATION FREIN

182 187 191

TIPO RADDRIZZATORE AC/DC
RECTIFIER TYPE
GLEICHRICHTERTYP
TYPE ALIMENTATEUR
NB, SB, NBR, SBR

183

LEVA DI SBLOCCO FRENO
BRAKE HAND RELEASE
BREMSENTHANDLÜFTUNG
LEVIER DE DEBLOCAGE FREIN
R, RM

194

COPPIA FRENANTE / BRAKE TORQUE
BREMSMOMENT/ COUPLE FREIN

184 188 192

TIPO FRENO / BRAKE TYPE
BRESENTYP / TYPE DE FREIN

FD (freno c.c./ d.c. brake / G.S. Bremse / frein c.c.)
FA, BA (freno c.a./ a.c. brake / W.S. Bremse / frein c.a.)

181 186 190

POSIZIONE MORSETTIERA / TERMINAL BOX POSITION
KLEMMENKASTENLAGE / POSITION BOITE A BORNE
W (default), **N, E, S**

31

FORMA COSTRUTTIVA / MOTOR MOUNTING
BAUFORM / FORM DE CONSTRUCTION

— (motore integrato / compact motor
kompaktes Motor / moteur compact)

B5 (motore IEC / IEC - motor / IEC Motor / moteur IEC)

CLASSE ISOLAMENTO / INSULATION CLASS
ISOLIERUNGSKLASSE / CLASSE ISOLATION

CL F standard
CL H option

175

GRADO DI PROTEZIONE / DEGREE OF PROTECTION
SCHUTZART / DEGRE DE PROTECTION

IP55 standard (IP54 - motore autofrenante / brake motor / Bremssmotor / moteur frein)

169

TENSIONE - FREQUENZA / VOLTAGE - FREQUENCY
SPANNUNG - FREQUENZ / TENSION - FREQUENCE

174

NUMERO DI POLI / POLE NUMBER / POLZAHL / N.bre POLES
2, 4, 6, 2/4, 2/6, 2/8, 2/12, 4/6, 4/8

GRANDEZZA MOTORE / MOTOR SIZE / MOTOR-BAUGRÖSSE / TAILLE MOTEUR

05B - 5LA (motore integrato / compact motor / kompaktes Motor / moteur compact)

63A - 250M (motore IEC / IEC motor / IEC - motor / moteur IEC)

TIPO MOTORE / MOTOR TYPE / MOTORTYP / TYPE MOTEUR

M = trifase integrato / compact 3-phase / kompaktes Dreiphasen / 3 phasé compact

BN = trifase IEC / IEC 3-phase / IEC Dreiphasen / 3 phasé IEC

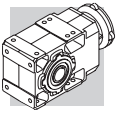

Opzioni riduttori

AL, AR

Antiretro. Nel par. 28 sono riportati i sensi di rotazione da indicare e i tipi di riduttori nei quali è applicabile il dispositivo antiretro.

SO

I riduttori tipo A05, A10, A20 e A30, A35 e A41 solitamente riempi in fabbrica di lubrificante, sono in questo caso forniti privi di olio.

LO

I riduttori A50, A55, A60, A70, A80, A90, solitamente sprovvisti di lubrificante, sono richiesti con olio sintetico del tipo correntemente utilizzato da BONFIGLIOLI RIDUTTORI e riempiti in accordo alla posizione di montaggio richiesta.

DV

2 Anelli di tenuta sull'albero veloce. (Disponibile solo sui motoriduttori compatti).

VV

Anello di tenuta in fluoro-elastomero sull'albero veloce.

PV

Tutti gli anelli di tenuta in fluoro-elastomero.

HDB

Per le applicazioni caratterizzate da presenza di carichi radiali particolarmente rilevanti, e per le quali la capacità radiale offerta dai riduttori in esecuzione standard non è sufficiente, alcuni riduttori possono essere richiesti con capacità radiale maggiorata specificando nell'ordinativo l'opzione HDB. L'opzione è disponibile per i riduttori delle grandezze da A10 ad A50 qualora dotati di albero lento cilindrico, sia a singola che a doppia sporgenza. I carichi supportabili dai gruppi in esecuzione rinforzata sono riportati nella tabella seguente. I valori sono riferiti all'applicazione di forze sulla mezzeria dell'albero lento.

Gearbox options

AL, AR

Anti-run back device. Directions of rotation to be indicated and types of gearboxes in which the anti-run back device can be installed are listed in chapter 28.

SO

Gear units A05, A10, A20, A30, A35 and A41, usually factory filled with oil, are, in this case, supplied unlubricated.

LO

Gearboxes A50, A55, A60, A70, A80 and A90, usually supplied without oil, to be supplied with synthetic oil currently used by BONFIGLIOLI RIDUTTORI and filled according to the mounting position specified.

DV

Dual oil seals on input shaft. (Only available for integral gearmotors).

VV

Fluoro elastomer oil seal on input shaft.

PV

All oil seals in Fluoro elastomer material.

HDB

Certain gearboxes are available with increased overhung load ratings for use in applications characterised by high overhung loads beyond the capacity of the standard gearboxes. Specify the HDB option when ordering to obtain this increased overhung load capacity. The HDB option is available for gearbox sizes A10 to A50 with a single sided or through solid output shaft. The following table specifies the maximum loads for HDB reinforced gearbox versions. Figures refer to forces along the centreline of the output shaft.

Getriebe Optionen

AL, AR

Im Abschnitt 28 werden die anzugebenden Drehrichtungen und die Getriebearten angegeben, mit denen die Rücklaufsperre verwendet werden kann.

SO

Die Getriebetypen A05, A10, A20, A30, A35 und A41, das normalerweise sind mit Schmiermittel geliefert, werden ohne Öl geliefert.

LO

Für Getriebe A50, A55, A60, A70, A80 und A90, die gewöhnlich ohne Schmiermittel geliefert werden, in Übereinstimmung mit der Einbaulage gefüllt mit dem normalerweise von BONFIGLIOLI RIDUTTORI verwendeten synthetischen Schmierstoff.

DV

2 Wellendichtringe auf der eintreibenden Welle. (Nur für Kompaktgetriebemotoren).

VV

Wellendichtringe aus Fluor-Elastomer auf der eintreibenden Welle.

PV

Alle Wellendichtringe aus Fluor-Elastomer.

HDB

Für Anwendungen, die durch besonders hohe Radialkräfte gekennzeichnet sind und für die die zulässigen Radiallasten der Getriebe in Standardausführung nicht ausreichen, können einige Getriebe mit erhöhter zulässiger Radiallast durch Angabe der Option HDB bestellt werden. Die Option ist für die Getriebe der Größen A10 bis A50, mit einseitiger oder zweiseitiger Abtriebswelle verfügbar. Die zulässigen Radiallasten der Getriebe in verstärkter Ausführung sind in der nachfolgenden Tabelle angegeben. Die Werte beziehen sich auf Lasten die in der Mitte der Abtriebswelle angreifen.

Options réducteurs

AL, AR

Le paragraphe 28 indique le sens de rotation à signaler et les types de réducteur dans les quels on peut appliquer le dispositif anti-retour.

SO

Les réducteurs A05, A10, A20, A30, A35 et A41, habituellement fourni avec lubrifiant, sont livrés sans huile.

LO

Les réducteurs A50, A55, A60, A70, A80 et A90, habituellement dépourvus de lubrifiants, sont demandés avec huile synthétique du type couramment utilisé par BONFIGLIOLI RIDUTTORI et remplis conformément à la position de montage demandée.

DV

2 bagues d'étanchéité sur l'arbre rapide. (Disponible seulement sur les motoréducteurs compacts).

VV

Bague d'étanchéité en Elastomère fluoré sur l'arbre rapide.

PV

Toutes les bagues d'étanchéité en Elastomère fluoré.

HDB

Pour les applications caractérisées par la présence de charges radiales particulièrement importantes et pour lesquelles la capacité radiale offerte par les réducteurs en exécution standard n'est pas suffisante, il est possible de commander certains réducteurs dotés d'une capacité radiale augmentée en précisant l'option HDB lors de la commande. Cette option est disponible pour les réducteurs à partir du A10 et jusqu'au A50, s'ils sont dotés d'un arbre lent cylindrique à simple ou double saillie. Les charges pouvant être supportées par les groupes en exécution renforcée sont indiquées dans le tableau suivant. Les valeurs font référence à l'application de forces au centre de l'arbre lent.

(B1)

HDB	RN2					
	A 10	A 20	A 30	A 35	A 41	A 50
$n_1 = 2800$	5500 N	6200 N	9600 N	12000 N	15000 N	20000 N
			8970 N @ i=5.4	10200 N @ i=5.4 10600 N @ i=6.4 11000 N @ i=7.0	11500 N @ i=5.2 12700 N @ i=7.1 13300 N @ i=8.3 13700 N @ i=9.2	19000 N @ i=7.7
$n_1 = 1400$	5500 N	6200 N	9600 N	12000 N	15000 N	20000 N
$n_1 = 900$	5500 N	6200 N	9600 N	12000 N	15000 N	20000 N
$n_1 = 500$	5500 N	6200 N	9600 N	12000 N	15000 N	20000 N

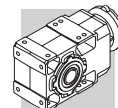

I cuscinetti di tipo rinforzato consentono anche l'applicazione di una percentuale maggiore di carico assiale, in particolare:

Reinforced bearings also allow these versions to withstand increased thrust loads, and in particular.

Durch die verstärkte Lagerung sind auch höhere Axiallasten zulässig, und zwar:

Les roulements renforcés permettent également l'application d'un pourcentage de charge axiale plus important, notamment :

$$A_{N2} = 0.35 \times R_{N2}$$

In assenza di componente radiale il carico assiale applicabile è:

In applications free from overhung load, thrust load capacity increases to:

Bei Applikationen ohne Radiallasten beträgt die Axialkraft:

En l'absence d'une charge radiale, la charge axiale applicable est :

$$A_{N2} = 0.70 \times R_{N2}$$

Nel caso di forze applicate contemporaneamente su entrambe le sporgenze dell'albero lento è consigliato contattare il Servizio Tecnico di Bonfiglioli per la verifica del caso puntuale.

If load is applied simultaneously to both ends of a through output shaft, contact the Bonfiglioli Technical Service to verify the application.

Sollen gleichzeitig an beiden Wellenenden der Abtriebswelle Kräfte wirken, empfiehlt sich zur Prüfung des jeweiligen Falls die Kontaktaufnahme mit dem technischen Kundendienst von Bonfiglioli.

En cas de forces appliquées simultanément sur les deux saillies de l'arbre lent, il est recommandé de contacter le Service technique de Bonfiglioli pour la vérification.

Accessori

Vedi capitolo 35 di questo catalogo.

Accessories

See chapter 35 of this catalogue.

Zubehör

siehe Kapitel 35 des Kataloges.

Accessoires

Voir le chapitre 35 de ce catalogue.

Opzioni motori

AA, AC, AD

Posizione angolare leva di sblocco freno rispetto alla posizione morsettiera visto lato ventola. Posizione standard = 90° orari. AA = 0°, AC = 180°, AD = 90° antiorari.

Motor options

AA, AC, AD

Angular position of the brake release lever with respect to the terminal box, looking from fan side. Standard position = 90° clockwise. AA = 0°, AC = 180°, AD = 90° counterclockwise.

Optionen Motoren

AA, AC, AD

Geben die Lage des Bremslüfterhebels zum Klemmenkastens an. Standard ist 90° im Uhrzeigersinn beim Ansehen der Lüfterradseite. AA = 0°, AC = 180°, AD = 90° entgegen dem Uhrzeigersinn.

Options moteurs

AA, AC, AD

Position angulaire du levier de déblocage du frein par rapport à la position de la boîte à borne en regardant du côté du ventilateur. Position standard = 90° sens horaire. AA = 0°, AC = 180°, AD = 90° sens anti-horaire.

AL, AR

Per i motoriduttori equipaggiati con motore integrale serie M, è disponibile l'opzione antiretro collocata sul motore stesso e descritta nella sezione motori elettrici di questo catalogo. La tabella B2 mostra il senso di rotazione libera del riduttore in base alla quale dovrà essere effettuata la scelta dell'opzione.

AL, AR

A backstop device on the motor itself, as described in the electric motors section of this catalogue, is available for gearmotors with integral M Series motors. Table B2 shows the direction of free rotation of the gearbox, on the basis of which the correct option must be selected.

AL, AR

Für Getriebemotoren mit Integralmotor der Baureihe M steht die Option Rücklaufsperrung zur Verfügung, welche auf dem Motor selbst installiert ist und im Abschnitt über die Elektromotoren in diesem Katalog beschrieben wird. Die Tabelle B2 zeigt die freie Drehrichtung des Getriebemotors, anhand welcher die Option entsprechend gewählt werden muss.

AL, AR

Pour les motoréducteurs équipés d'un moteur intégral de série M, l'option antirecul située sur le moteur même et décrite dans la section moteurs électriques de ce catalogue est disponible. Le tableau B2 montre le sens de rotation libre du réducteur, sur la base de laquelle devra être effectué le choix de l'option.

(B2)

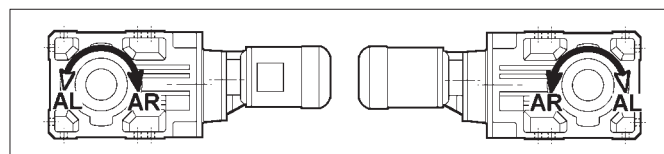
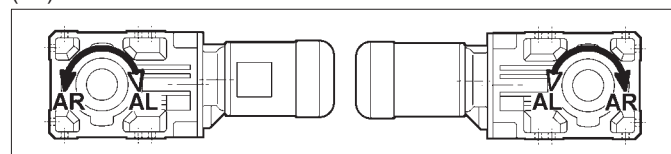

2x	A 05	A 10	A 20	A 30	A 35	A 41	A 50	A 60
3x	A 60	A 70	A 80	A 90				
4x	A 50	A 55						

2x	A 55							
3x	A 20	A 30	A 35	A 41	A 50	A 55		
4x	A 60	A 70	A 80	A 90				

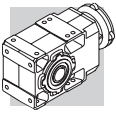

CF Filtro capacitivo.	CF <i>Capacitive filter.</i>	CF Kapazitive filter.	CF <i>Filtre capacitif.</i>
D3 No. 3 sonda bimetalliche negli avvolgimenti con temperatura 150°C.	D3 <i>3 bimetallic winding temperature sensors, calibrated at 150°C.</i>	D3 3 Bimetallfühler in den Wicklungen mit Temperatur von 150°C.	D3 <i>3 sondes bimétalliques dans les enroulements à une température de 150 °C.</i>
E3 No. 3 termistori negli avvolgimenti con temperatura 150°C.	E3 <i>3 winding temperature thermistors, calibrated at 150°C.</i>	E3 3 Kaltleiterthermistoren in den Wicklungen mit Temperatur von 150°C.	E3 <i>3 thermistances dans les enroulements à une température de 150 °C.</i>
F1 Volano per avviamento progressivo.	F1 <i>Flywheel for soft start and stop.</i>	F1 Schwungrad zum sanften Anfahren.	F1 <i>Volant pour démarrage progressif.</i>
H1 Riscaldatori anticondensa. Alimentazione standard 1~ 230V ±10%.	H1 <i>Anti condensate heaters. Standard voltage 1~ 230V ±10%.</i>	H1 Wicklungsheizung Standardspannung 1~ 230 V ±10%	H1 <i>Réchauffeurs anticondensation. Alimentation standard 1~ 230V ±10%.</i>
PN Potenza a 60 Hz corrispondente alla potenza normalizzata a 50 Hz.	PN <i>60 Hz power corresponding to the normalized 50 Hz power.</i>	PN Die 60 Hz-Leistung wird an der 50 Hz-Normleistung ausgeglichen.	PN <i>Puissance à 60 Hz correspondante à la puissance normalisée à 50 Hz.</i>
PS Doppia estremità d'albero (esclude opzione RC e U1).	PS <i>Double shaft extention (barring RC and U1 options).</i>	PS Zweites Wellenende (schließt die Optionen RC und U1 aus).	PS <i>Double extrémité d'arbre (à l'exclusion de l'option RC et U1).</i>
RC Tettuccio parapigioggia (esclude opzione PS).	RC <i>Drip cover (barring option PS).</i>	RC Schutzdach (schließt Option PS aus).	RC <i>Capot protection antipluie (option PS exclue).</i>
RV Bilanciamento rotore in grado di vibrazione B.	RV <i>Rotor balancing in vibration class B.</i>	RV Läufer in Vibrationsgrad B ausgewuchtet.	RV <i>Equilibrage rotor avec degré de vibration B.</i>
TC La variante del tettuccio tipo TC è da specificare quando il motore è installato in ambienti dell'industria tessile. L'opzione esclude le varianti EN1, EN2, EN3 e non è applicabile ai motori con freno tipo BA.	TC <i>Option TC is a rain canopy variant for textile industry environments. This option is not compatible with variants EN1, EN2, EN3 and will not fit motors equipped with a BA brake.</i>	TC Bei dieser Option handelt es sich um ein Schutzdachs mit einem Textilnetz, dessen Einsatz empfohlen wird wenn der Motor in Bereichen der Textilindustrie installiert wird. Diese Option schließt die Möglichkeit der Optionen EN1, EN2, EN3 aus und kann bei Bremsemotoren vom Typ BN_BA nicht montiert werden.	TC <i>La variante du capot type TC est à spécifier lorsque le moteur est installé dans des sites de l'industrie textile. L'option exclue les variantes EN1, EN2, EN3 et n'est pas applicable aux moteurs avec frein type BA.</i>
TP Tropicalizzazione.	TP <i>Tropicalization.</i>	TP Tropfenfestigkeit.	TP <i>Tropicalisation.</i>
U1 Servoventilazione (esclude opzioni PS e CUS).	U1 <i>Forced cooling (barring options PS and CUS).</i>	U1 Fremdbelüftung (Nicht anwendbare Gesamtheit an den Optionen PS und CUS).	U1 <i>Servo-ventilateur (Pas applicable ensemble aux options PS et CUS).</i>
U2 Servoventilatore privo di scatola morsettiera, dotato di cavi precablati internamente. Esclude le opzioni PS e CUS. Disponibile per motori: BN 71 ... BN 132, M1 ... M4.	U2 <i>Separate supply forced ventilation without terminal box. Cables are pre-wired. Configuration is not compatible with options PS and CUS. Available on motors; BN 71 ... BN 132, M1 ... M4.</i>	U2 Servoventilator ohne Klemmenkasten, bereits intern verkabelt. Nicht anwendbare Gesamtheit an den Optionen PS und CUS. Verfügbar für folgende Motoren: BN 71 ... BN 132, M1 ... M4.	U2 <i>Servoventilateur sans boîte à bornes, doté de câbles précâblés à l'intérieur. Pas applicable ensemble aux options PS et CUS. Disponible pour moteurs : BN 71 ... BN 132, M1 ... M4.</i>
Per ulteriori informazioni sulle opzioni, consultare i relativi capitoli nella sezione motori elettrici.	For further information on options, consult the electric motors section.	Siehe die Kapitel im Teil Elektromotoren für weitere Informationen.	Pour de plus amples informations sur les options, consulter la section moteurs électriques.

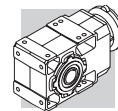

23 - LUBRIFICAZIONE

Gli organi interni dei riduttori Bonfiglioli sono lubrificati con un sistema misto di immersione e sbattimento dell'olio.

I gruppi A 05, A 10, A 20, A 30, A 35 e A 41 sono normalmente consegnati con carica di lubrificante dalla fabbrica, o dalla rete di vendita ufficiale.

I gruppi di grandezza A 50 e superiore sono normalmente forniti privi di lubrificante, e sarà cura dell'utilizzatore riempirli di olio prima della messa in servizio.

In entrambi i casi, a seconda delle versioni, prima della messa in esercizio del riduttore potrebbe essere necessario sostituire il tappo chiuso usato per il trasporto con il tappo di sfianto fornito a corredo.

Le tavole che seguono sono da riferimento nell'interpretazione delle posizioni di montaggio, della collocazione dei tappi di servizio e delle quantità di lubrificante.

Queste ultime sono indicative; per il corretto riempimento si dovrà fare riferimento tassativamente alla mezzeria del tappo di livello trasparente o all'astina (tacca di riferimento) o allo sfioramento del foro del tappo, quando presenti.

Rispetto a questa condizione la quantità di lubrificante riportata in tabella può presentare scostamenti, occasionalmente anche rilevanti.

Il lubrificante "long life" fornito di serie è di natura sintetica e, a meno di contaminazione dall'esterno, non richiede sostituzioni periodiche per tutto l'arco di vita del riduttore.

Il funzionamento dei riduttori è ammesso per temperature ambiente comprese fra -20°C e $+40^{\circ}\text{C}$. Per temperature ambiente comprese fra -20°C e -10°C l'avviamento del riduttore potrà avvenire solo dopo aver effettuato un pre-riscaldamento progressivo ed omogeneo del gruppo, oppure con funzionamento "a vuoto", senza carico collegato.

Il carico potrà poi essere applicato all'albero del riduttore quando la temperatura dello stesso avrà raggiunto la temperatura di -10°C , o superiore.

23 - LUBRICATION

The inner parts of Bonfiglioli gear units are oil-bath and splash lubricated.

Frame sizes A 05, A 10, A 20, A 30, A 35 and A 41 are supplied by the factory, or by the authorized dealers, already filled with oil.

Unless otherwise specified, units size A 50 and larger are usually supplied unlubricated at it will be the customer care to fill them with oil prior to putting them into operation.

In both cases, depending on the version, prior to putting the gear unit into operation may need to replace the closed plug used for transportation purposes with breather plug supplied with.

The charts here after must be referred to as for the mounting position pattern and the corresponding oil plugs, if applicable, and related lubricant quantity.

These figures are only indicative; to ensure correct filling, always refer to the centreline of the sight glass, the notch on the dipstick, or the spill level of the filler plug hole, whichever is present.

In some cases, discrepancies, occasionally also substantial, versus the oil quantities listed in the chart may be noticed.

The "long life" polyglycol-based lubricant supplied by the factory, in the absence of contamination, does not require periodical oil changes throughout the life of the gear unit.

Operation of gear units is permitted at ambient temperatures between -20°C and $+40^{\circ}\text{C}$. However, for temperatures between -20°C and -10°C unit may only start up after it has been progressively and evenly pre-heated, or otherwise initially operated unloaded.

Load may then be connected to the output shaft when the gear unit has reached the temperature of -10°C , or higher.

23 - SCHMIERUNG

Die Schmierung der Getriebe von Bonfiglioli erfolgt durch eine Kombination aus Ölbad- und Tauchschmierung.

Die Getriebegrößen A 05, A 10, A 20, A 30, A 35 und A 41 sind ab Werk mit einer Lebensdauerschmierung versehen.

Die Getriebe ab der Größe A 50 werden ohne Ölfüllung ausgeliefert. Vor der Inbetriebnahme muss deshalb auf das Einfüllen der richtigen Ölfüllmenge geachtet werden!

In beiden Fälle, nach den Ausführungen, vor der Inbetriebnahme, könnte notwendig sein, den geschlossenen Pfropfen mit dem Entlüftungspfropfen, der zusammen mit dem Getriebe geliefert ist, zu wechseln.

Bitte beachten Sie dazu auch die nachfolgenden Kapitel über die Positionen der Stopfen und Ölschaugläser und den entsprechenden Ölfüllmengen.

Die Letztgenannten sind Richtwerte; zur korrekten Befüllung ist obligatorisch auf die Mittellinie des durchsichtigen Öleinfüllstopfens, den Messstab (Markierung) oder den Überlaufschutz des Stopfens, sofern vorhanden, Bezug zu nehmen.

Auf Abweichungen gegenüber den in der Tabelle angegebenen Ölmengen, gelegentlich nicht unwesentliche, wird hingewiesen.

Die mit Lebensdauerschmierung gelieferten Serien sind mit synthetischem Öl auf Polyglykollbasis gefüllt. Falls dieses Öl nicht verunreinigt wird, ist während der Lebensdauer des Getriebes kein Ölwechsel nötig.

Die Getriebe dürfen bei einer Umgebungstemperatur von -20°C bis $+40^{\circ}\text{C}$ betrieben werden. Allerdings darf ein Start unter Last bei -20°C bis -10°C erst nach stufenweiser und gleichmäßiger Vorwärmung erfolgen. Anderfalls muss das Anfahren ohne Last erfolgen.

Die Last darf erst zugeschaltet werden, wenn die Getriebeinheit eine Temperatur von mindestens -10° oder höher erreicht hat.

23 - LUBRIFICATION

Les organes internes des réducteurs Bonfiglioli sont lubrifiés avec un système mixte d'immersion et de battement de l'huile.

Les groupes A 05, A 10, A 20, A 30, A 35 et A 41 sont normalement livrés avec charge de lubrifiant de l'usine, ou du réseau de vente officielle.

Les groupes de grandeur A 50 et supérieur sont normalement fournis sans lubrifiant, et sera par l'utilisateur le remplissage d'huile avant la mise en service.

Dans les deux cas, selon les versions, avant la mise en service du réducteur, il pourrait être nécessaire de remplacer le bouchon fermé utilisé pour le transport par le bouchon d'évent fourni.

Les tables suivantes sont de référence dans l'interprétation des positions de montage, du placement des bouchons de service et de la quantité de lubrifiant.

Ces dernières sont indicatives; pour un remplissage correct, il faut se référer obligatoirement au milieu du bouchon de niveau transparent ou à la jauge (encoche de repère) ou à l'effleurement du trou du bouchon, quand ils existent.

Par rapport à cette condition la quantité de lubrifiant indiqué dans le tableau peut présenter des écarts, occasionnellement considérables.

Le lubrifiant "long life"; fourni de série est de nature synthétique et, à moins de contamination par l'extérieur, il ne demande pas des remplacements périodiques pour tout l'arc de vie du réducteur.

Le fonctionnement des réducteurs est admis pour des températures ambiantes comprises entre -20°C et $+40^{\circ}\text{C}$. Pour des températures ambiantes comprises entre -20°C et -10°C le démarrage du réducteur est admis seulement après un préchauffage progressif et homogène, ou avec un fonctionnement « à vide », sans charge appliquée.

La charge pourra être ensuite appliquée à l'arbre du réducteur quand celui-ci aura atteint une température de -10°C , ou supérieure.

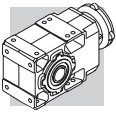

(B3)

Viscosità olio ISO VG / Oil viscosity ISO VG / Öl-Viskosität ISO VG / Viscosité de l'huile ISO VG					
	Ta ≤ -20°	-20° < Ta ≤ 10°	0° ≤ Ta ≤ 30°	20° ≤ Ta ≤ 40°	Ta > 40°
Mineral EP	(*)	150	320	460	460 (*)
PAO EP	(*)	150	220	320	460 (*)
PAG	(*)	150	220	320	460 (*)

PAO Oli sintetici polialfaolefine

PAO Polyalphaolefin synthetic oils

PAO Synthetische Poly-Alpha-Olefin-Öle

PAO Huiles synthétiques polyalphaoléfines

(*) consultare il Servizio Tecnico Commerciale.

(*) consult Bonfiglioli Technical Service.

(*) Bitte wenden Sie sich an die technische Abteilung von Bonfiglioli.

(*) Consulter le service technique Bonfiglioli.

Per i riduttori **A 05...A 60** usare sempre e solo olio sintetico tipo **PAG** (a base poliglicolica) con viscosità ISO VG 320.

When filling bevel helical gear units of models **A 05 to A 60** use exclusively a **PAG** (poly-glycol-based) synthetic oil with viscosity ISO VG 320.

Zur Befüllung der Kegelgetriebe Baugröße **A 05** bis **A 60** darf ausschließlich **PAG** (auf Polyglycol basierend) synthetisches Öl mit der Viskosität von ISO VG 320 verwendet werden.

Pour les réducteurs **A 05 à A 60**, utiliser exclusivement une huile synthétique à base de polyglycol (**PAG**) d'une viscosité ISO VG 320.

Quantità di lubrificante [l]

Oil quantity [l]

Schmiermittelmenge

Quantité de lubrifiant [l]

(B4)

	oil [l]					
	B3	B6	B7	B8	VA	VB
						
A 05 2	0.45	0.45	0.45	0.45	0.45	0.45
A 10 2	0.50	0.70	0.60	0.90	0.90	1.0
A 20 2	1.4	1.3	1.1	1.8	1.9	1.5
A 20 3	1.5	1.7	1.2	2.0	2.4	1.8
A 30 2	2.1	1.6	2.2	2.5	3.1	2.2
A 30 3	2.0	1.8	2.3	2.6	3.6	2.3
A 35 2	2.9	2.7	3.2	3.5	4.2	3.2
A 35 3	3.8	3.7	4.2	4.4	5.2	4.3
A 41 2	3.1	3.3	3.1	4.6	4.8	3.4
A 41 3	3.7	3.9	3.8	5.2	5.7	3.9
A 50 2	6.1	10	6.2	10	11	12
A 50 3	6.1	10	6.2	10	11	12
A 50 4	6.3	8.2	5.3	9.0	13	9.0
A 55 2	4.8	7.1	7.9	8.3	9.5	10
A 55 3	3.9	6.7	3.3	7.5	9.2	7.8
A 55 4	5.2	9.1	9.0	8.6	11	8.6
A 60 2	9.0	9.0	14	16	18	16
A 60 3	9.0	9.0	14	16	18	16
A 60 4	8.0	11	7.4	16	19	14
A 70 3	12	13	8.5	13	20	11
A 70 4	14	14	11	13	21	14
A 80 3	20	21	15	25	31	22
A 80 4	22	18	15	25	39	22
A 90 3	38	34	35	44	64	40
A 90 4	41	34	35	46	71	40

Lubrificazione permanente

Life lubricated

Dauerschmierung

Lubrification permanente

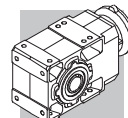

24 - POSIZIONI DI MONTAGGIO E ORIENTAMENTO MORSETTIERA

Gli orientamenti delle morsettiere dei motori sono identificati osservando il motore dal lato ventola; l'orientamento standard è evidenziato in nero (W).

Posizione angolare leva di sblocco freno.

Nei motori autofrenanti, la leva di sblocco freno (se richiesta) ha l'orientamento standard a 90° rispetto alla morsetteria (posizione AB); specificare con relative opzioni qualora l'orientamento desiderato sia diverso.

24 - MOUNTING POSITION AND TERMINAL BOX ANGULAR LOCATION

Location of motor terminal box can be specified by viewing the motor from the fan side; standard location is shown in black (W).

Angular location of the brake release lever.

Unless otherwise specified, brake motors have the manual device side located, 90° apart from terminal box. Different angles can be specified through the relevant options available.

24 - EINBAULAGEN UND LAGE DES KLEMMENKASTENS

Die Angaben zur Lage des Klemmenkastens beziehen sich auf das von der Lüfterseite her betrachtete Getriebe. Die Standardorientierung ist schwarz hervorgehoben (W).

Winkellage des Handlüfterhebels.

Bei Bremsmotoren wird der Handlüfterhebel (auf Anfrage) standardmäßig auf 90° gegenüber des Klemmkastens (AB-Anordnung) geliefert; wird eine andere Anordnung verlangt, muß dies bei der Bestellung durch das geeignete Option angegeben werden.

24 - POSITIONS DE MONTAGE ET ORIENTATION BOITE A BORNE

Les orientations des boîtes à bornes des moteurs sont définies en regardant le moteur du côté ventilateur. L'orientation standard est indiquée en noir (W).

Position angulaire levier déblocage frein.

Dans les moteurs freins, ce levier (si requis) aura l'orientation standard de 90° par rapport à la boîte à bornes (position AB); spécifier avec options relatives si l'orientation désirée est différente.

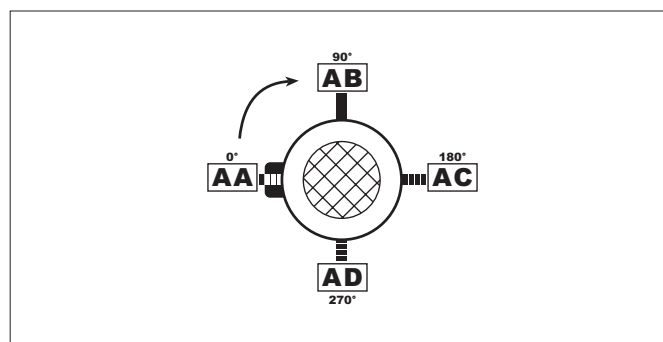

(B5)

	Legenda:	Key:	Zeichenerklärung:	Légende:
	Tappo di sfiato / carico	Filling / breather plug	Einfüll / Ablassschraube	Bouchon de event / remplissage
	Tappo di livello	Level plug	Ölstandsschraube	Bouchon de niveau
	Tappo di scarico	Drain plug	Ölablassschraube	Bouchon de vidange
	Tappo in vista	Plug in sight	Sichtbarer Deckel	Bouchon visible
	Tappo non in vista	Plug not in sight	Nicht sichtbarer Deckel	Bouchon non visible

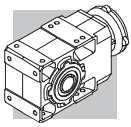

A 05 ... A 41

HS

P (IEC)

S

B3

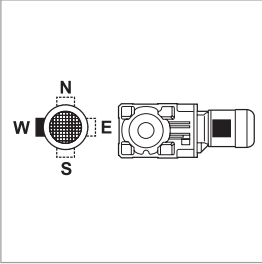
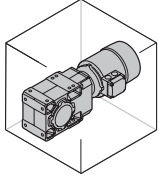

W = Default

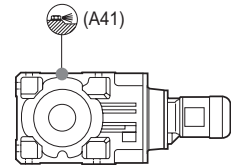
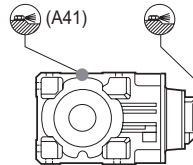
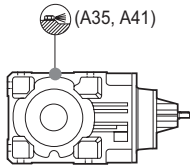
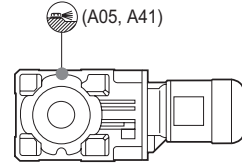
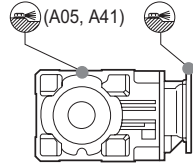
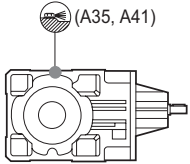

B6

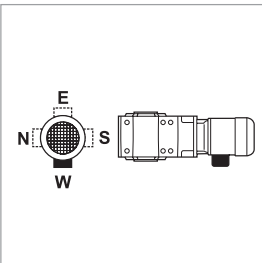
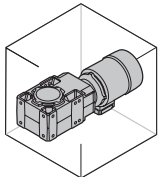

W = Default

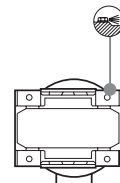
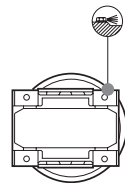
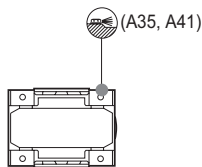
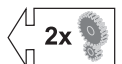
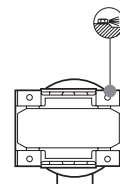
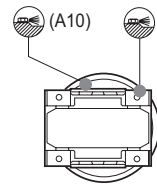
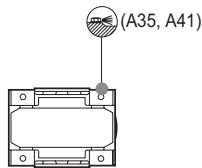

B7

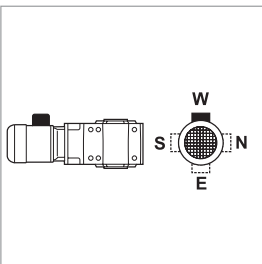
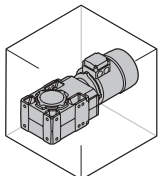

W = Default

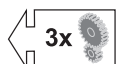
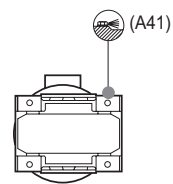
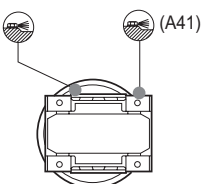
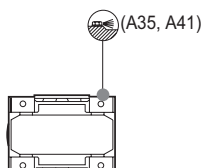
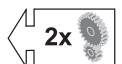
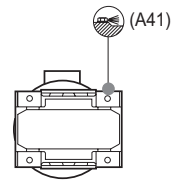
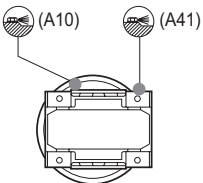
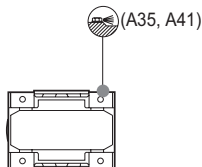

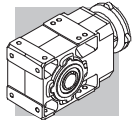

A 05 ... A 41

HS

P (IEC)

S

B8

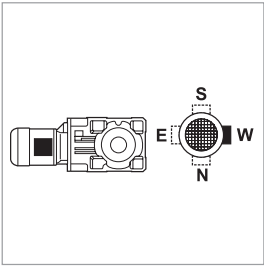
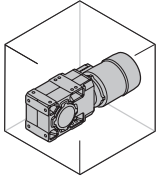

W = Default

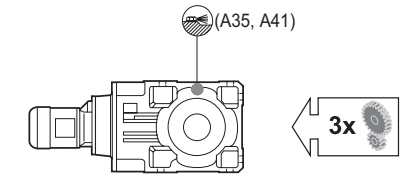
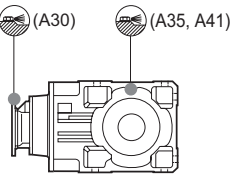
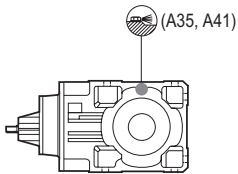
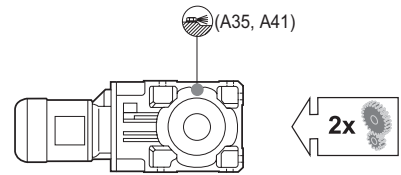
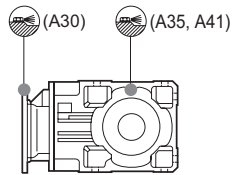
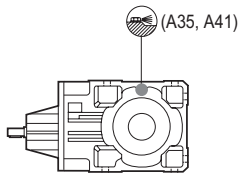

VA

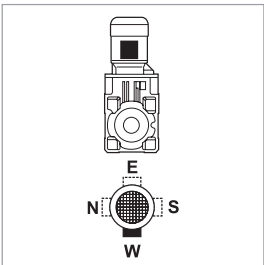
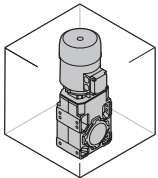

W = Default

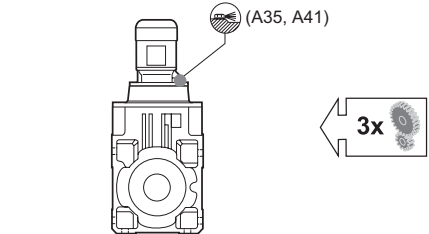
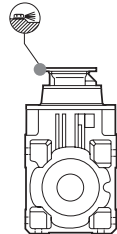
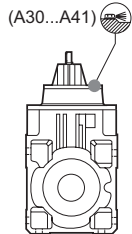
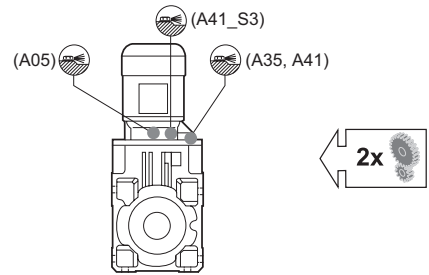
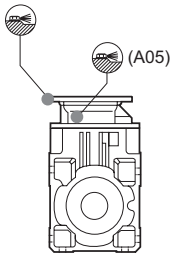
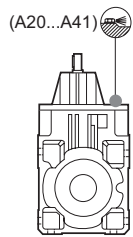

VB

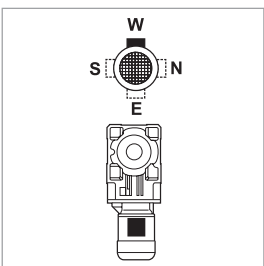
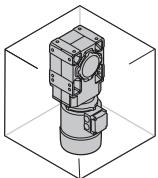

W = Default

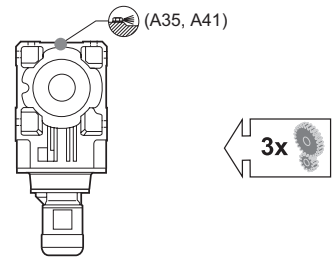
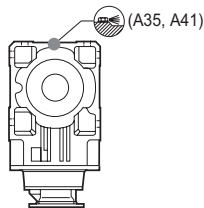
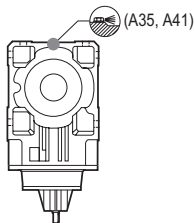
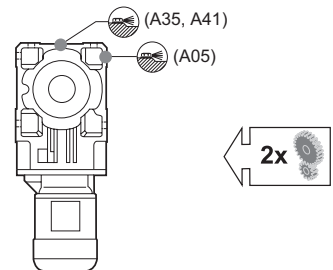
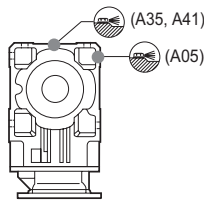
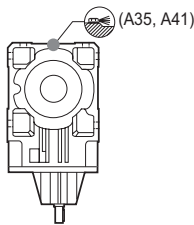

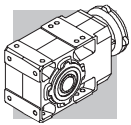

A 50 ... A 60

HS

P (IEC)

S

B3

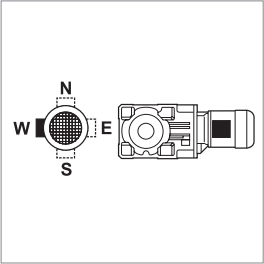
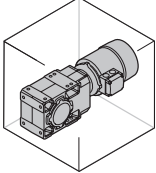

W = Default

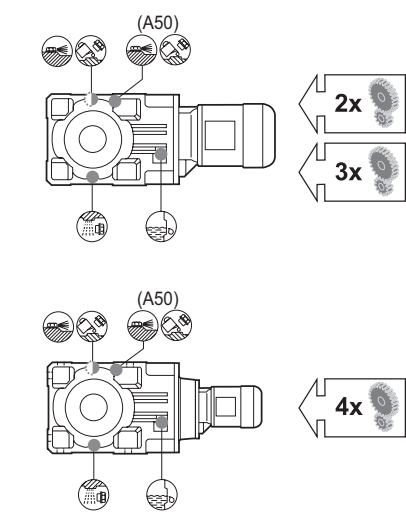
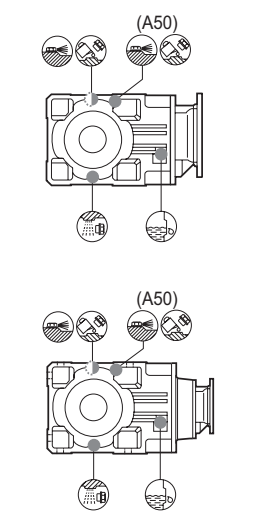
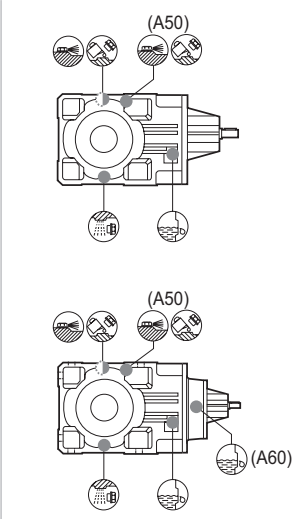

B6

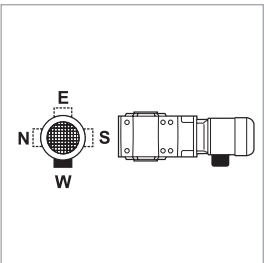
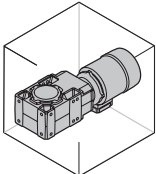

W = Default

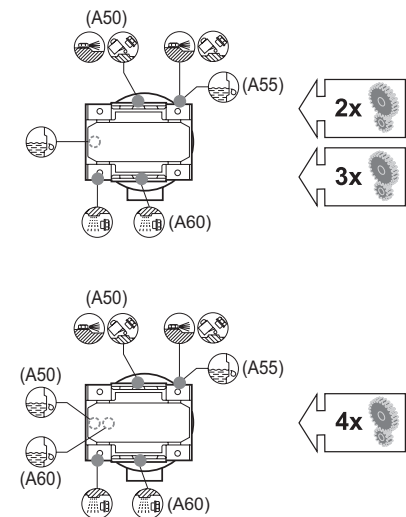
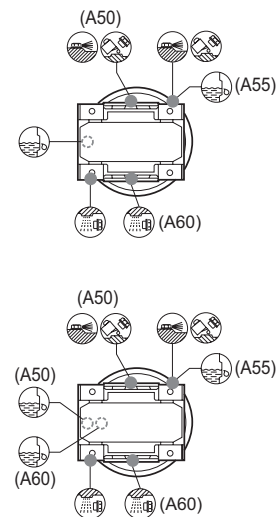
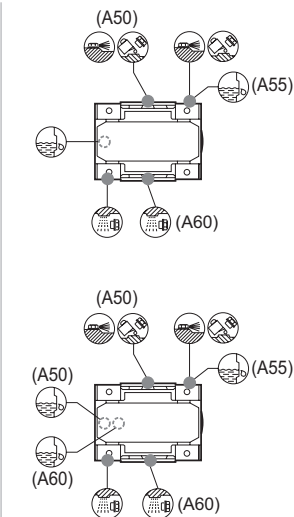

B7

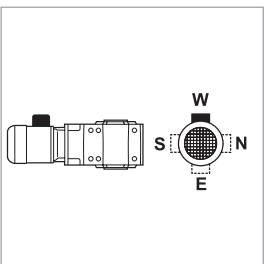
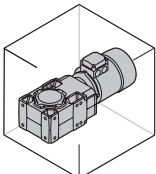

W = Default

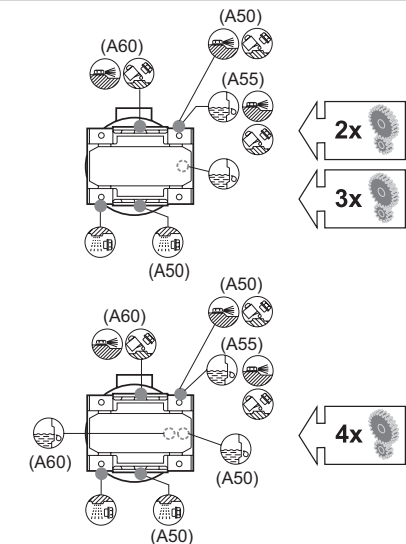
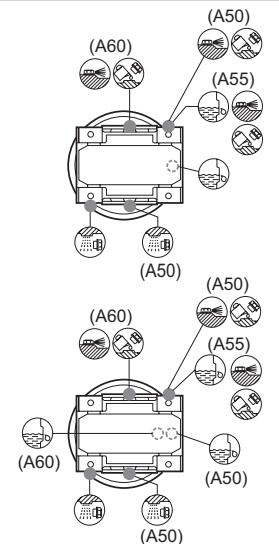
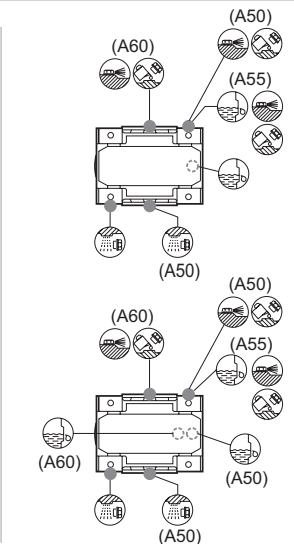

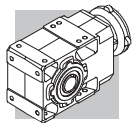

A 50 ... A 60

HS

P (IEC)

S

B8

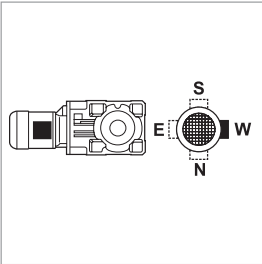
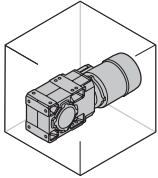

W = Default

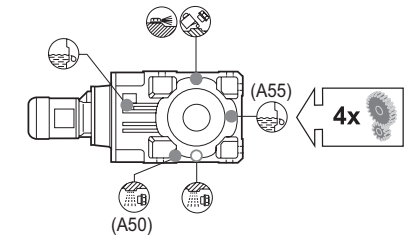
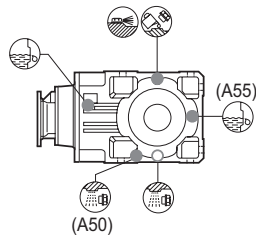
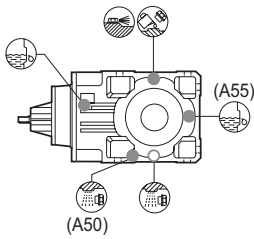
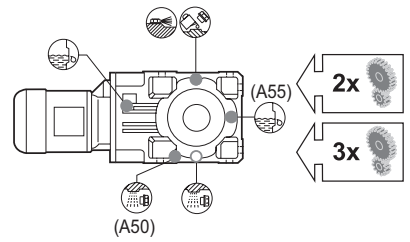
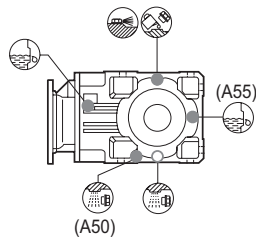
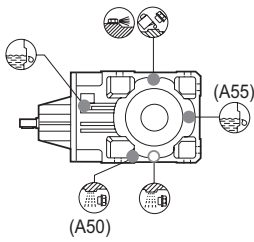

VA

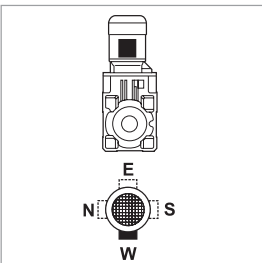
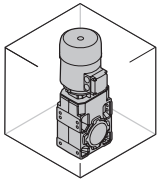

W = Default

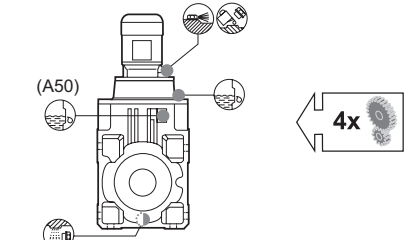
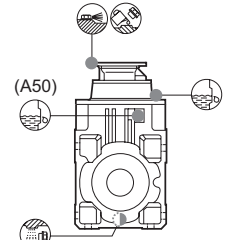
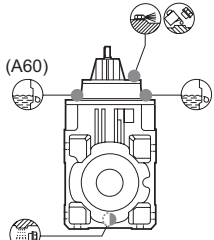
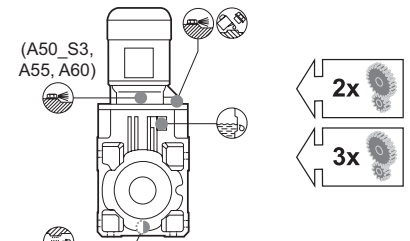
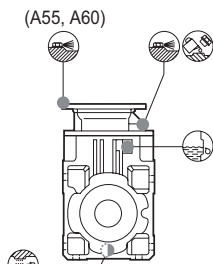
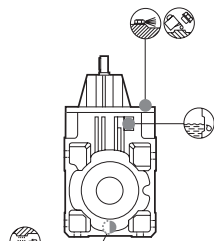

VB

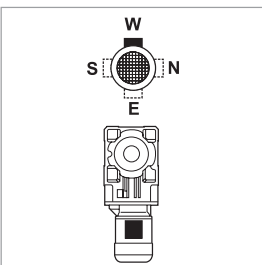
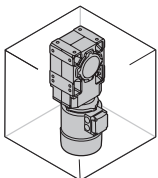

W = Default

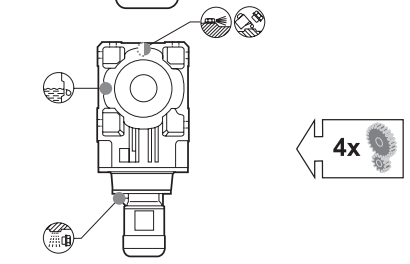
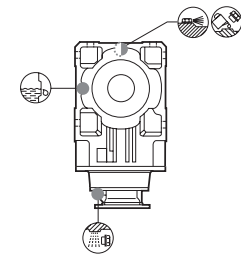
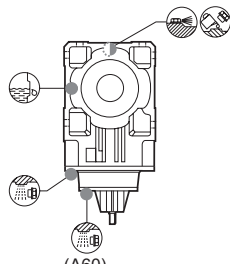
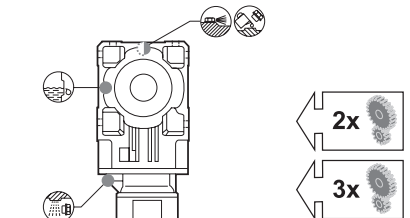
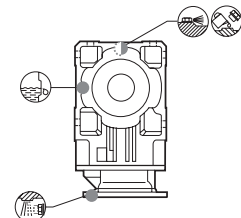
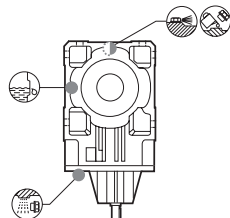

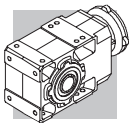

A 70 ... A 90

HS

P (IEC)

S

B3

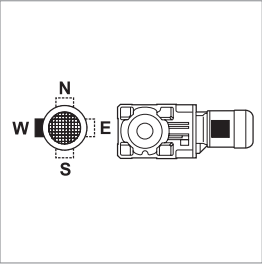
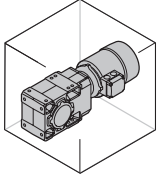

W = Default

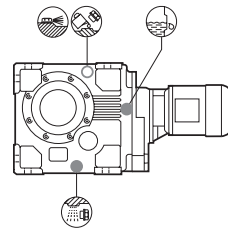
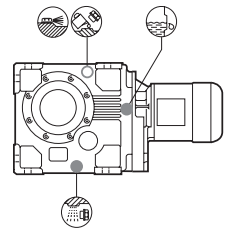
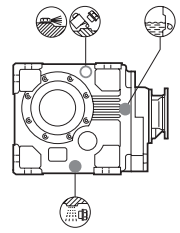
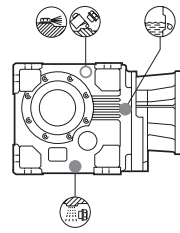
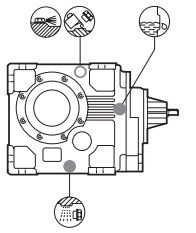
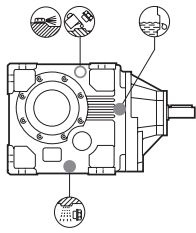

← 3x

← 4x

B6

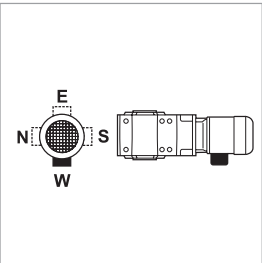
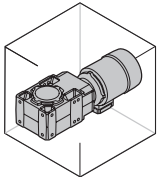

W = Default

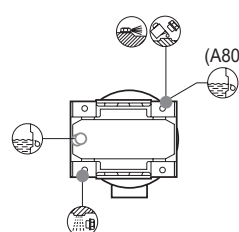
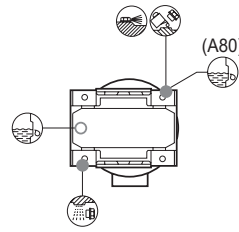
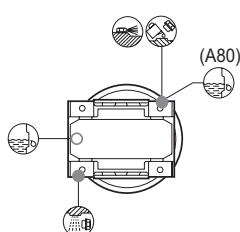
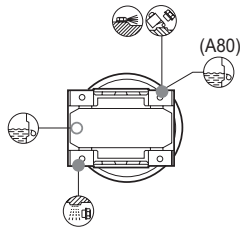
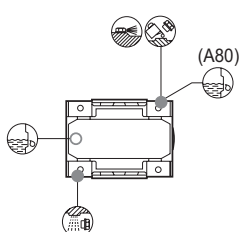
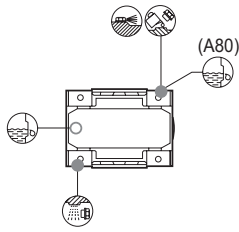

← 3x

← 4x

B7

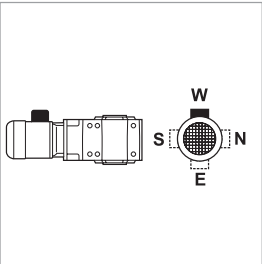
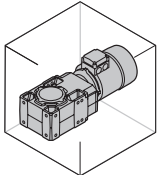

W = Default

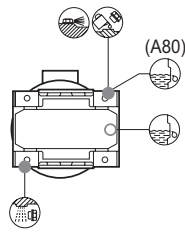
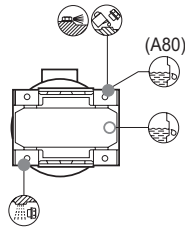
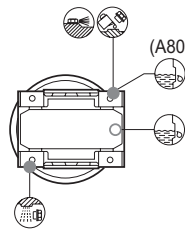
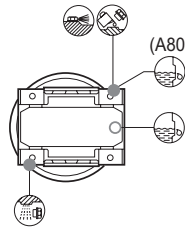
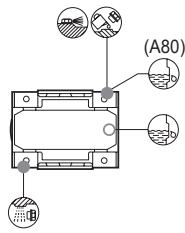
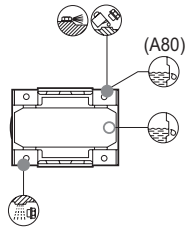

← 3x

← 4x

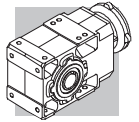

A 70 ... A 90

HS

P (IEC)

S

B8

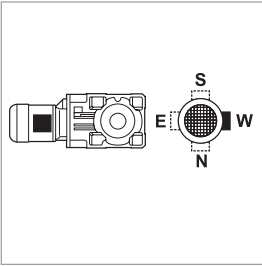
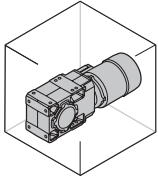

W = Default

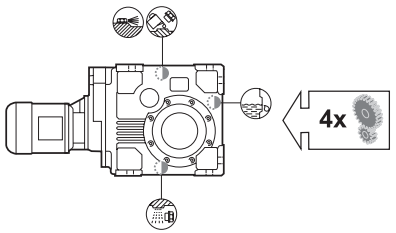
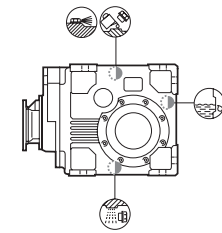
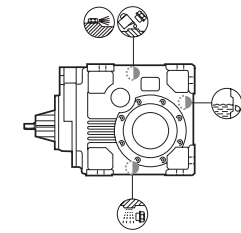
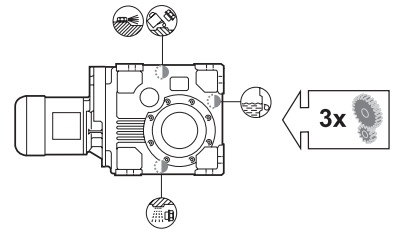
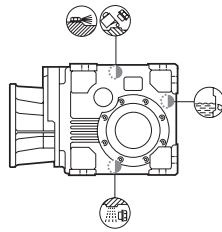
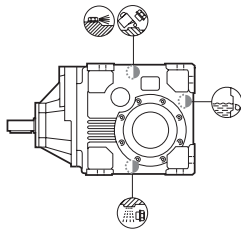

VA

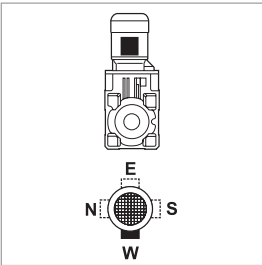
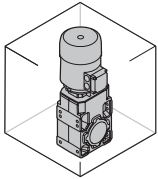

W = Default

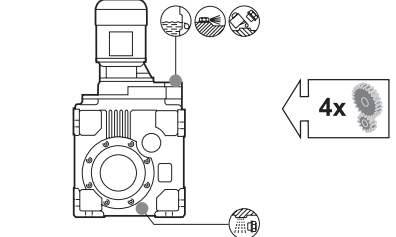
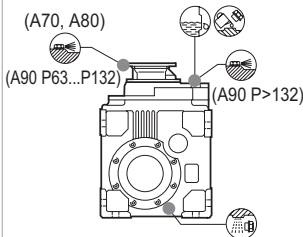
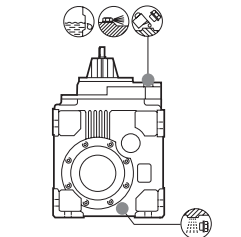
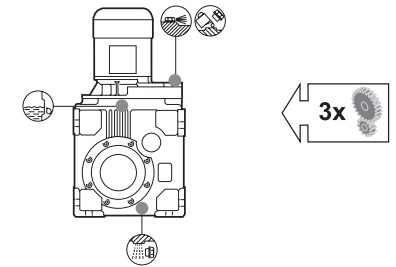
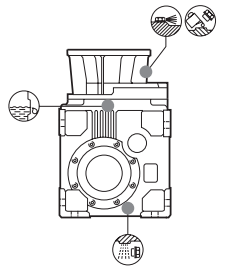
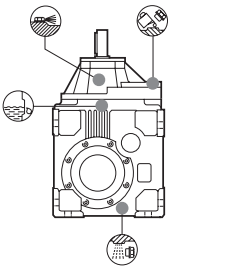

VB

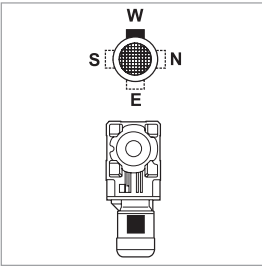
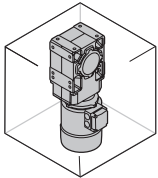

W = Default

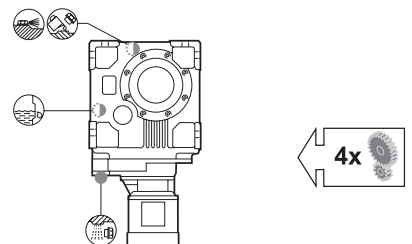
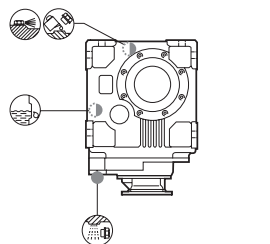
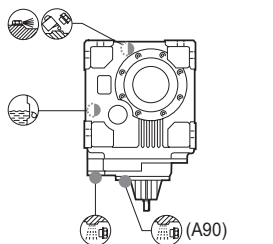
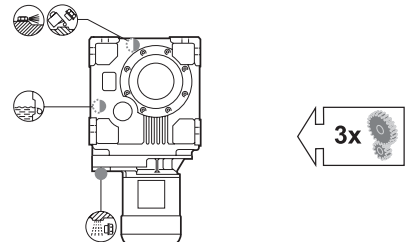
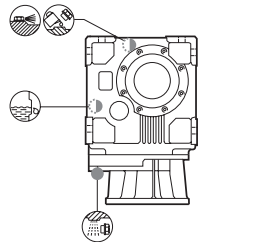
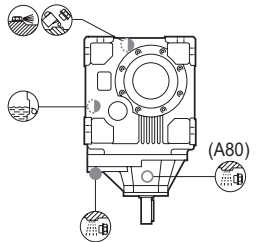

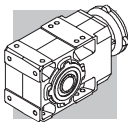

25 - CARICHI RADIALI

Organi di trasmissione calettati sugli alberi di ingresso e/o di uscita del riduttore generano forze la cui risultante agisce in senso radiale sull'albero stesso. L'entità di questi carichi deve essere compatibile con la capacità di sopportazione del sistema albero-cuscinetti del riduttore, in particolare il valore assoluto del carico applicato (R_{c1} per albero di ingresso, R_{c2} per albero di uscita) deve essere inferiore al valore nominale (R_{n1} per albero di ingresso, R_{n2} per albero di uscita) riportato nelle tabelle dati tecnici.

Nelle formule che seguono l'indice (1) si riferisce a grandezze relative all'albero veloce, l'indice (2) all'albero lento.

Il carico generato da una trasmissione esterna può essere calcolato, con buona approssimazione, tramite la formula seguente:

25 - OVERHUNG LOADS

External transmissions keyed onto input and/or output shaft generate loads that act radially onto same shaft.

Resulting shaft loading must be compatible with both the bearing and the shaft capacity. Namely shaft loading (R_{c1} for input shaft, R_{c2} for output shaft), must be equal or lower than admissible overhung load capacity for shaft under study (R_{n1} for input shaft, R_{n2} for output shaft). OHL capability listed in the rating chart section.

In the formulas given below, index (1) applies to parameters relating to input shaft, whereas index (2) refers to output shaft.

The load generated by an external transmission can be calculated with close approximation by the following equations:

25 - RADIALKRÄFTE

Die mit den Antriebs- und/oder Abtriebswellen des Getriebes verbundenen Antriebsorgane bilden Kräfte, die in radiale Richtung auf die Welle selbst wirken. Das Ausmaß dieser Kräfte muß mit der Festigkeit des Systems aus Getriebewelle/-lager kompatibel sein, insbesondere muß der absolute Wert der angetragenen Belastung (R_{c1} für Antriebswelle und R_{c2} für Abtriebswelle) unter dem in den Tabellen der Technischen Daten angegebenen Nennwert (R_{n1} für Antriebswelle und R_{n2} für Abtriebswelle) liegen.

In den nachstehenden Formeln bezieht sich die Angabe (1) auf die Maße der Antriebswelle, die Angabe (2) auf die Abtriebswelle. Die von einem externen Antrieb erzeugte Kraft kann, recht genau, anhand der nachstehenden Formel berechnet werden:

25 - CHARGES RADIALES

Les organes de transmission ca-lés sur les arbres d'entrée et/ou de sortie du réducteur génèrent des forces dont la résultante agit sur l'arbre dans le sens radial.

L'entité de ces charges doit être compatible avec la capacité d'endurance du système arbre-roulements du réducteur. Plus particulièrement, la valeur absolue de la charge appliquée (R_{c1} pour l'arbre d'entrée, R_{c2} pour l'arbre de sortie) doit être inférieure à la valeur nominale (R_{n1} pour l'arbre d'entrée, R_{n2} pour l'arbre de sortie) indiquée dans les tableaux des données techniques.

Dans les formules qui suivent, l'indice (1) se réfère à des tailles relatives à l'arbre rapide, l'indice (2) concerne l'arbre lent.

La charge générée par une transmission extérieure peut être calculée, avec une bonne approximation, au moyen de la formule suivante:

$$R_{c1} [N] = \frac{2000 \cdot M_1 [Nm] \cdot K_r}{d [mm]} ; R_{c2} [N] = \frac{2000 \cdot M_2 [Nm] \cdot K_r}{d [mm]} \quad (15)$$

M_1 [Nm]	Coppia applicata all'albero veloce	Torque applied to input shaft	Drehmoment auf die Antriebswelle	Couple appliqué à l'arbre rapide
M_2 [Nm]	Coppia erogata all'albero lento	Torque drawn at output shaft	Drehmoment auf die Abtriebswelle	Couple délivré par l'arbre lent
d [mm]	Diametro primitivo dell'organo calettato sull'albero	Pitch diameter of element keyed onto shaft	Teilkreisdurchmesser von Bewegungselement, der auf der Abtriebswelle aufgeschumpft ist	Diamètre primitif de l'organe monté sur l'arbre
$K_r = 1$	Trasmissione con catena	Chain transmission	Kettenantrieb	Transmission à chaîne
$K_r = 1,25$	Trasmissione con ingranaggio	Gear transmission	Zahnradantrieb	Transmission à engrenage
$K_r = 1,5$	Trasmissione a cinghia trapezoidale	V-belt transmission	Antrieb über Keilriemen	Transmission à courroie trapézoïdale
$K_r = 2,0$	Trasmissione a cinghia piatta	Flat belt transmission	Antrieb über Flachriemen	Transmission à courroie plate

In base al punto di applicazione del carico sull'albero la verifica di compatibilità procederà in modi diversi e in particolare:

Verification of OHL capability varies depending on whether load applies at midpoint of shaft or it is shifted further out:

In Abhängigkeit zum Kraftangriffspunkt an der Welle erfolgt die Kontrolle hinsichtlich der Kompatibilität in unterschiedlicher Weise und insbesondere:

En fonction du point d'application de la charge sur l'arbre, la vérification de la compatibilité sera différente, plus particulièrement:

(B6)

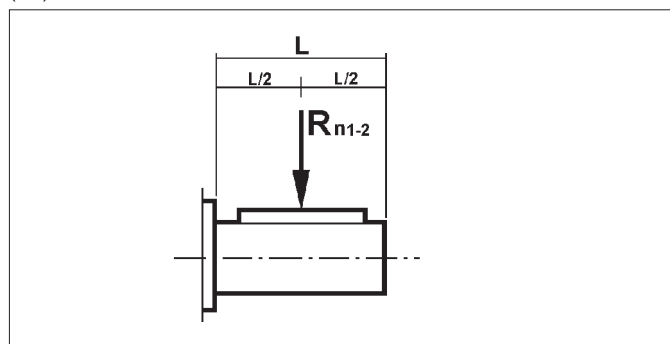

(B7)

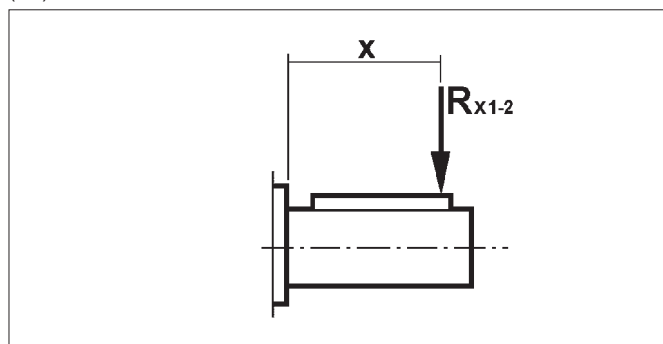

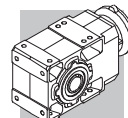

a) Applicazione in mezzzeria, tab. (B6)

Il carico precedentemente calcolato si dovrà confrontare con il corrispondente valore nominale esposto a catalogo e dovrà verificarsi:

$$R_{c1} \leq R_{n1} \text{ [albero veloce]}$$

oppure

$$R_{c2} \leq R_{n2} \text{ [albero lento]}$$

a) Load applied at midpoint of shaft, tab. (B6)

A comparison of shaft loading with catalogue OHL ratings should verify the following condition:

$$R_{c1} \leq R_{n1} \text{ [input shaft]}$$

or

$$R_{c2} \leq R_{n2} \text{ [output shaft]}$$

a) Kraftangriffspunkt in der Mitte, Tab. (B6)

Der zuvor errechnete Wert muß mit dem im Katalog angegebenen Nennwert verglichen werden. Es muß sich folgendes ergeben:

$$R_{c1} \leq R_{n1} \text{ [Antriebswelle]}$$

oder

$$R_{c2} \leq R_{n2} \text{ [Abtriebswelle]}$$

a) Application au milieu, tab. (B6)

La charge précédemment calculée doit être comparée avec la valeur nominale correspondante indiquée dans le catalogue, on doit vérifier :

$$R_{c1} \leq R_{n1} \text{ [arbre rapide]}$$

ou

$$R_{c2} \leq R_{n2} \text{ [arbre lent]}$$

b) Applicazione spostata dalla mezzzeria, tab. (B7)

L'applicazione del carico ad una distanza "x" dalla battuta dell'albero comporta il ricalcolo del valore ammissibile a detta distanza.

Il nuovo valore è individuato con i simboli R_{x1} (ingresso) e R_{x2} (uscita) e si ricava dai valori di catalogo, rispettivamente R_{n1} e R_{n2} , tramite l'elaborazione del fattore:

b) Load off the midpoint tab. (B7)

When load is shifted at an "x" distance from shaft shoulder, permissible load must be calculated for that distance.

Revised permissible overhung loads R_{x1} (input) and R_{x2} (output) are calculated respectively from original rated values R_{n1} and R_{n2} through factor:

b) Von der Mitte versetzter Kraftangriffspunkt Tab.(B7)

Der auf einer Distanz "x" vom Wellenansatz liegende Kraftangriffspunkt fordert eine erneute Berechnung des für diesen Abstand zulässigen Werts.

Der neue Wert wird mit den Symbolen R_{x1} (Antrieb) und R_{x2} (Abtrieb) gekennzeichnet und unter Anwendung der nachstehenden Faktorberechnung aus den Katalog-werten R_{n1} und R_{n2} :

b) Application déplacée du milieu, tab. (B7)

L'application de la charge à une distance "x" de la butée de l'arbre implique un nouveau calcul de la valeur admissible à cette distance.

La nouvelle valeur est indiquée par les symboles R_{x1} (entrée) et R_{x2} (sortie) ou peut être calculée diaprès les valeurs de catalogue, respectivement R_{n1} et R_{n2} , en élaborant le facteur:

$$\frac{a}{b+x} \quad (16)$$

(B8)

	Costanti del riduttore / Load location factors / Getriebekonstanten / Constantes du réducteur					
	Albero lento / Output shaft Abtriebswelle / Arbre lent			Albero veloce / Input shaft Antriebswelle / Arbre rapide		
	a	b	c	a	b	c
A 05 2	116	86	450	—	—	—
A 10 2	123	101	600	21	1	300
A 20 2	150	120	750	40	20	350
A 20 3	150	120	750	21	1	300
A 30 2	168	138	900	38.5	18.5	350
A 30 3	168	138	900	21	1	300
A 35 2	182.5	147.5	950	38.5	18.5	350
A 35 3	182.5	147.5	950	21	1	300
A 41 2	198	158	1050	49.5	24.5	450
A 41 3	198	158	1050	40	20	350
A 50 2 - A 50 3	242.5	201.5	1300	49.5	24.5	450
A 50 4	242.5	201.5	1300	38.5	18.5	350
A 55 2 - A 55 3	231.5	179	1300	49.5	24.5	450
A 55 4	231.5	179	1300	38.5	18.5	350
A 60 2 - A 60 3	242.5	190	1550	55.5	25.5	600
A 60 4	242.5	190	1550	49.5	24.5	450
A 70 3	295.5	230.5	1900	86	31	1000
A 70 4	295.5	230.5	1900	49.5	24.5	450
A 80 3	345	280	2400	86	31	1000
A 80 4	345	280	2400	49.5	24.5	450
A 90 3	432	327	3000	116	46	1400
A 90 4	432	327	3000	49.5	24.5	450

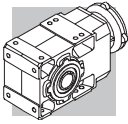

La procedura di verifica comporta passi successivi che sono qui descritti.

Verification procedure is described here after.

Das Kontrollverfahren zieht die nachstehend beschriebenen Schritte nach sich.

La procédure de vérification comporte les pas successifs indiqués ici.

ALBERO VELOCE

INPUT SHAFT

ANTRIEBSWELLE

ARBRE RAPIDE

1. Calcolo di:

1. Calculate:

1. Berechnung von:

1. Calcul de:

$$R_{x1} = R_{n1} \cdot \frac{a}{b+x}$$

(17)

N.B. A condizione che:

N.B. Subject to condition:

HINWEIS unter der Bedingung, daß:

N.B. A condition que:

$$\frac{L}{2} \leq x \leq c$$

(18)

Infine si dovrà verificare che:

Finally, the following condition must be verified:

Dies als Voraussetzung, muß sich folgendes ergeben:

Ensuite, vérifier que:

$$R_{c1} \leq R_{x1}$$

(19)

ALBERO LENTO

OUTPUT SHAFT

ABTRIEBSWELLE

ARBRE LENT

1. Calcolo di:

1. Calculate:

1. Berechnung von:

1. Calcul de:

$$R_{x2} = R_{n2} \cdot \frac{a}{b+x}$$

(20)

N.B. A condizione che:

N.B. Subject to condition:

HINWEIS unter der Bedingung, daß:

N.B. A condition que:

$$\frac{L}{2} \leq x \leq c$$

(21)

Infine si dovrà verificare che:

Finally, the following condition must be verified:

Dies als Voraussetzung, muß sich folgendes ergeben:

Ensuite, vérifier que:

$$R_{c2} \leq R_{x2}$$

(22)

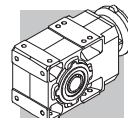

26 - CARICHI ASSIALI, A_{n1}, A_{n2}

I valori di carico assiale ammissibile sugli alberi veloce [A_{n1}] e lento [A_{n2}] si possono ricavare con riferimento al corrispondente valore di carico radiale [R_{n1}] e [R_{n2}] tramite le espressioni che seguono:

26 - THRUST LOADS, A_{n1}, A_{n2}

Permissible thrust loads on input [A_{n1}] and output [A_{n2}] shafts are obtained from the radial loading for the shaft under consideration [R_{n1}] and [R_{n2}] through the following equation:

$$A_{n1} = R_{n1} \cdot 0,2$$

$$A_{n2} = R_{n2} \cdot 0,2$$

26 - CHARGES AXIALES, A_{n1}, A_{n2}

Les valeurs de charge axiale admissible sur les arbres rapides [A_{n1}] et lent [A_{n2}] peuvent être calculées, en se référant à la valeur de charge radiale correspondante [R_{n1}] et [R_{n2}] au moyen des formules suivantes :

(23)

I valori di carico assiale ammissibile così calcolati si riferiscono al caso di forze assiali agenti contemporaneamente ai carichi radiali nominali.

Nel solo caso in cui il valore del carico radiale agente sull'albero del riduttore sia nullo, si può considerare il carico assiale ammissibile [A_n] pari al 50% del valore di carico radiale ammissibile [R_n] sullo stesso albero.

In presenza di carichi assiali eccedenti il valore ammissibile, o di forze assiali fortemente prevalenti sui carichi radiali, è consigliabile contattare il Servizio Tecnico di Bonfiglioli Riduttori per una verifica puntuale.

The thrust loads calculated through these formulas apply to thrust forces occurring at the same time as rated radial loads. In the only case that no overhung load acts on the shaft the value of the admissible thrust load [A_n] amounts to 50% of rated OHL [R_n] on same shaft. Where thrust loads exceed permissible value or largely prevail over radial loads, contact Bonfiglioli Riduttori for an in-depth analysis of the application.

Die so errechneten Werte der zulässigen Axialkräfte beziehen sich auf den Fall, in dem die Axialkräfte gleichzeitig mit den Nennradialkräften einwirken.

Nur im Fall, es keine Radialbelastung auf die Getriebewelle gibt, ist der Wert der zulässigen Axialbelastung [A_n] gleich zu 50% der zulässigen Radialbelastung [R_n] auf die gleiche Welle. In Anwesenheit von übermäßigen Axialkräften, oder stark auf die Radialkräfte einwirkende Kräfte, wird im Hinblick auf eine genaue Kontrolle empfohlen, sich mit dem Technischen Kundendienst der Bonfiglioli Riduttori in Verbindung zu setzen.

Les valeurs de charge axiale admissible ainsi calculées se réfèrent au cas de forces axiales agissant en même temps que les charges radiales nominales.

Dans le seul cas la valeur de la charge radiale agissant sur l'arbre soit nul, l'on peut considérer la charge axiale admissible [A_n] égale à 50% de la valeur de la charge radiale admissible [R_n] sur le même arbre.

En présence de charges axiales excédant la valeur admissible, ou de forces axiales fortement supérieures aux charges radiales, il est conseillé de contacter le Service Technique Bonfiglioli Riduttori pour une vérification.

27 - ROTAZIONE ALBERI

Negli schemi riportati nella tabella (B9) sono indicati i sensi di rotazione standard dei riduttori ad assi ortogonali a 2, 3 e 4 stadi di riduzione.

27 - SHAFTS ARRANGEMENT

Table (B9) shows standard directions of rotation for 2, 3 and 4 stage helical-bevel gearboxes.

27 - WELLENDREHUNG

Die auf die Tabelle (B9) angegebenen Bilder zeigen die Standarddrehrichtungen der 2-, 3- und 4-stufigen Kegelstirnradgetrieben.

27 - ROTATION ARBRES

Dans les schémas reportés dans le tableau (B9) sont indiqués les sens de rotation standard des réducteurs avec arbres orthogonaux à 2, 3 et 4 étages de réduction.

(B9)

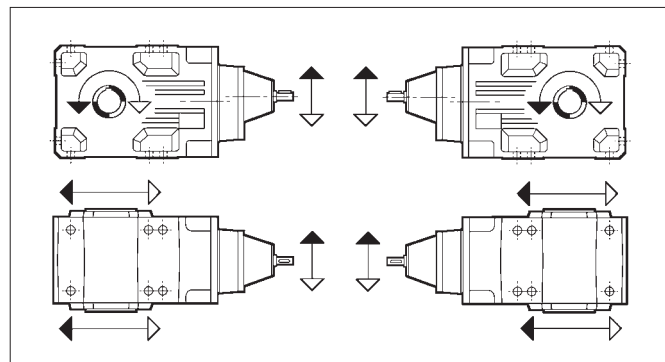
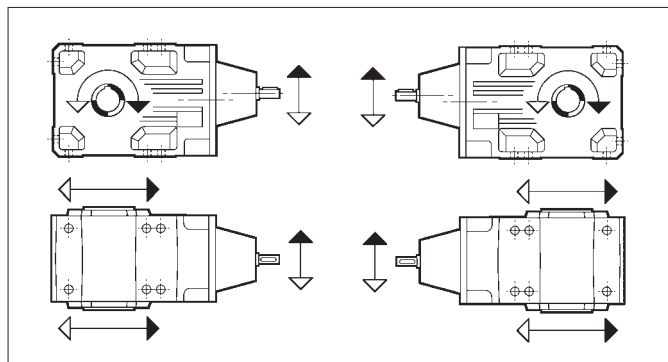

2x	A 05	A 10	A 20	A 30	A 35	A 41	A 50	A 60
3x	A 60	A 70	A 80	A 90				
4x	A 50	A 55						

2x	A 55						
3x	A 20	A 30	A 35	A 41	A 50	A 55	
4x	A 60	A 70	A 80	A 90			

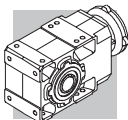

28 - DISPOSITIVO ANTIRETRO

A richiesta si può fornire il riduttore munito di dispositivo antiretro che permette la rotazione dell'albero lento solo nel senso desiderato (opzione AL-AR). La tabella (B10) indica i riduttori nei quali è possibile applicare il dispositivo antiretro.

28 - ANTI-RUN BACK DEVICE

On request the gear unit can be provided complete with a backstop device allowing the output shaft to rotate only in the direction specified at the time of ordering – option AL/AR. Table B10 shows the gearboxes in which the anti-run back device can be installed.

28 - RÜCKLAUFSPERRE

Auf Anfrage kann das Getriebe mit einer Rücklaufsperrung ausgerüstet werden, um die Drehung der Abtriebswelle in nur einer Richtung zu ermöglichen - Option AL/AR. Auf der Tabelle B10 sind die Getriebe angegeben, mit denen die Rücklaufsperrung verwendet werden kann.

28 - DISPOSITIF ANTI-RETOUR

Sur demande le réducteur peut être fourni avec un dispositif anti-retour. Ce dispositif permet la rotation de l'arbre lent seulement dans le sens souhaité (option AL/AR). Le tableau B10 indique les réducteurs dans lesquels on peut appliquer le dispositif anti-retour.

(B10)

A 30 2*	A 35 2* ⊖ (5.4_11.8)	A 41 2 ⊖ (5.2; 10.1)	A 50 3	A 55 3	A 60 3	A 70 3	A 80 3	A 90 3
			A 50 4	A 55 4	A 60 4	A 70 4	A 80 4	A 90 4

* La fornitura del dispositivo antiretro esclude la dotazione di flange per servomotore del tipo S_60A, S_60B, S_80A.

* The supply of the backstop will ban the configuration of servomotor adapters type S_60A, S_60B, S_80A.

* Mit dem Rücklaufsperrung sind die Servoflanschen Typ S_60A, S_60B und S_80A unmöglich.

* La fourniture du dispositif anti-retour empêche l'utilisation des adaptations pour servomoteur de type S_60A, S_60B, S_80A.

In fase d'ordine specificare il senso di rotazione libera mediante le opzioni AL o AR (tabella B11) nella designazione riduttore o in quella del motore.

When ordering the gear unit, the direction of free rotation must be specified through either the AR or the AL option.

Bei Bestellung bitte die gewünschte freie Drehrichtung durch die Option AL oder AR (Tabelle B11) in den Getriebe oder Motorbezeichnung angeben.

A la commande on (tab. B11) doit préciser le sens de rotation libre en indiquant les options AL ou AR dans la désignation du réducteur ou du moteur.

⚠ N.B. Quando l'intervento del dispositivo antiretro è richiesto in maniera ripetitiva verificare che la coppia all'albero lento, risultante dall'applicazione del carico, non superi il 70% della coppia nominale M_{n2} per lo specifico riduttore.

⚠ N.B. When the anti-run back device operates very frequently make sure that the torque backdriving the gearbox does not exceed 70% of the rated torque M_{n2} for the captioned gear unit.

⚠ HINWEIS: Sollte ein Auslösen der Rücklaufsperrung wiederholt erforderlich sein, muss kontrolliert werden, dass der Drehmoment am Abtrieb, der sich aus der Applikation der Last ergibt, 70% des Nenndrehmoments M_{n2} für dieses spezifische Getriebe nicht übersteigt.



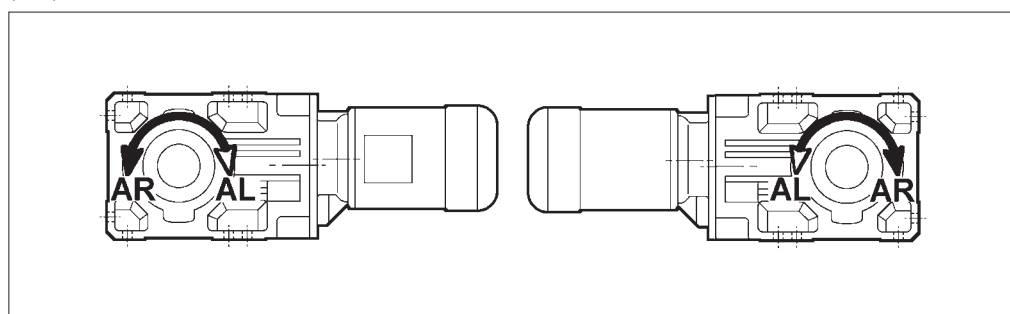

⚠ REMARQUE : Lorsque le dispositif anti-retour intervient très souvent, vérifier que le couple de l'arbre de sortie, résultant de l'application de la charge, ne dépasse pas 70% du couple nominal M_{n2} du réducteur en question.

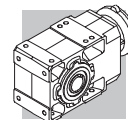
(B11)



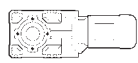





0.09 kW

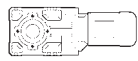

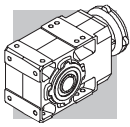

n ₂ min ⁻¹	M ₂ Nm	S	i	R _{n2} N			 IEC 	
0.51	1492	3.4	1715	50000			A704_1715 P63 BN63A6	151
1.1	677	2.2	778.2	20000			A504_778.2 P63 BN63A6	139
1.2	616	2.4	707.9	20000			A504_707.9 P63 BN63A6	139
1.4	549	2.7	631.2	20000			A504_631.2 P63 BN63A6	139
1.5	499	3.0	574.2	20000			A504_574.2 P63 BN63A6	139
1.7	461	3.3	529.5	20000			A504_529.5 P63 BN63A6	139
2.2	356	1.0	400.8	9600	A303_400.8 S05 M05A6	126	A303_400.8 P63 BN63A6	127
2.6	302	1.7	339.3	12000	A353_339.3 S05 M05A6	130	A353_339.3 P63 BN63A6	131
3.0	259	3.3	291.7	15000	A413_291.7 S05 M05A6	134	A413_291.7 P63 BN63A6	135
3.5	221	2.7	248.1	12000	A353_248.1 S05 M05A6	130	A353_248.1 P63 BN63A6	131
4.1	193	2.1	216.6	9600	A303_216.6 S05 M05A6	126	A303_216.6 P63 BN63A6	127
4.9	159	1.6	178.3	6200	A203_178.3 S05 M05A6	122	A203_178.3 P63 BN63A6	123
5.8	134	2.8	150.7	9600	A303_150.7 S05 M05A6	126	A303_150.7 P63 BN63A6	127
6.8	115	2.2	129.1	6200	A203_129.1 S05 M05A6	122	A203_129.1 P63 BN63A6	123
8.1	97	2.5	109.2	6200	A203_109.2 S05 M05A6	122	A203_109.2 P63 BN63A6	123
9.6	84	1.5	91.6	5500	A102_91.6 S05 M05A6	118	A102_91.6 P63 BN63A6	119
11.5	70	2.1	76.4	5500	A102_76.4 S05 M05A6	118	A102_76.4 P63 BN63A6	119
13.3	61	2.5	65.9	5500	A102_65.9 S05 M05A6	118	A102_65.9 P63 BN63A6	119
15.0	54	2.8	58.6	5500	A102_58.6 S05 M05A6	118	A102_58.6 P63 BN63A6	119
17.2	47	3.2	51.3	5500	A102_51.3 S05 M05A6	118	A102_51.3 P63 BN63A6	119
19.4	42	2.4	45.4	4250	A052_45.4 S05 M05A6	115	A052_45.4 P63 BN63A6	115
21.5	38	2.7	40.9	4120	A052_40.9 S05 M05A6	115	A052_40.9 P63 BN63A6	115
25.1	32	3.1	35.1	3950	A052_35.1 S05 M05A6	115	A052_35.1 P63 BN63A6	115
27.3	30	3.4	32.2	3850	A052_32.2 S05 M05A6	115	A052_32.2 P63 BN63A6	115
31	26	3.8	28.6	3720	A052_28.6 S05 M05A6	115	A052_28.6 P63 BN63A6	115
35	23	4.4	25.5	3590	A052_25.5 S05 M05A6	115	A052_25.5 P63 BN63A6	115
37	22	4.6	23.8	3520	A052_23.8 S05 M05A6	115	A052_23.8 P63 BN63A6	115
41	19.6	5.3	21.4	3410	A052_21.4 S05 M05A6	115	A052_21.4 P63 BN63A6	115
47	17.1	5.9	18.6	3270	A052_18.6 S05 M05A6	115	A052_18.6 P63 BN63A6	115
53	15.1	6.8	16.4	3150	A052_16.4 S05 M05A6	115	A052_16.4 P63 BN63A6	115
63	12.8	7.8	13.9	2990	A052_13.9 S05 M05A6	115	A052_13.9 P63 BN63A6	115
72	11.3	8.8	12.3	2880	A052_12.3 S05 M05A6	115	A052_12.3 P63 BN63A6	115
83	9.7	10.3	10.6	2740	A052_10.6 S05 M05A6	115	A052_10.6 P63 BN63A6	115
92	8.8	11.3	9.6	2670	A052_9.6 S05 M05A6	115	A052_9.6 P63 BN63A6	115
103	7.8	13.2	8.5	2570	A052_8.5 S05 M05A6	115	A052_8.5 P63 BN63A6	115
122	6.6	15.1	7.2	2440	A052_7.2 S05 M05A6	115	A052_7.2 P63 BN63A6	115
139	5.8	17.8	6.3	2340	A052_6.3 S05 M05A6	115	A052_6.3 P63 BN63A6	115
161	5.0	19.9	5.5	2230	A052_5.5 S05 M05A6	115	A052_5.5 P63 BN63A6	115

0.12 kW

n ₂ min ⁻¹	M ₂ Nm	S	i	R _{n2} N			 IEC 	
0.51	2012	2.5	1715	50000			A704_1715 P63 BN63B6	151
0.55	1857	2.7	1583	50000			A704_1583 P63 BN63B6	151
0.65	1579	3.2	1346	50000			A704_1346 P63 BN63B6	151
0.70	1457	3.4	1242	50000			A704_1242 P63 BN63B6	151
1.1	913	1.6	778.2	20000			A504_778.2 P63 BN63B6	139
1.2	818	3.4	697.3	30000			A604_697.3 P63 BN63B6	147
1.4	740	2.0	631.2	20000			A504_631.2 P63 BN63B6	139
1.6	621	2.4	529.5	20000			A504_529.5 P63 BN63B6	139
1.7	588	2.5	778.2	20000			A504_778.2 P63 BN63A4	139
1.9	535	2.8	707.9	20000			A504_707.9 P63 BN63A4	139
2.1	477	3.1	631.2	20000			A504_631.2 P63 BN63A4	139
2.4	434	3.5	574.2	20000			A504_574.2 P63 BN63A4	139
3.4	310	1.2	400.8	9600	A303_400.8 S05 M05A4	126	A303_400.8 P63 BN63A4	127
3.4	304	1.5	393.2	12000	A353_393.2 S05 M05A4	130	A353_393.2 P63 BN63A4	131
3.6	291	2.9	376.8	15000	A413_376.8 S05 M05A4	134	A413_376.8 P63 BN63A4	135
3.8	275	1.3	356.3	9600	A303_356.3 S05 M05A4	126	A303_356.3 P63 BN63A4	127
4.0	262	2.0	339.3	12000	A353_339.3 S05 M05A4	130	A353_339.3 P63 BN63A4	131





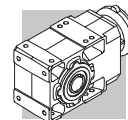

0.12 kW

n₂ min ⁻¹	M₂ Nm	S	i	R_{n2} N				
4.1	255	1.0	329.4	6200	A203_329.4 S05 M05A4	122	A203_329.4 P63 BN63A4	123
4.2	251	3.4	324.2	15000	A413_324.2 S05 M05A4	134	A413_324.2 P63 BN63A4	135
4.3	243	1.6	314.5	9600	A303_314.5 S05 M05A4	126	A303_314.5 P63 BN63A4	127
4.4	236	2.5	305.4	12000	A353_305.4 S05 M05A4	130	A353_305.4 P63 BN63A4	131
4.6	226	1.1	292.8	6200	A203_292.8 S05 M05A4	122	A203_292.8 P63 BN63A4	123
5.0	210	1.8	271.5	9600	A303_271.5 S05 M05A4	126	A303_271.5 P63 BN63A4	127
5.0	209	2.9	270.7	12000	A353_270.7 S05 M05A4	130	A353_270.7 P63 BN63A4	131
5.2	201	1.2	260.5	6200	A203_260.5 S05 M05A4	122	A203_260.5 P63 BN63A4	123
5.4	192	3.1	248.1	12000	A353_248.1 S05 M05A4	130	A353_248.1 P63 BN63A4	131
5.5	189	2.0	244.3	9600	A303_244.3 S05 M05A4	126	A303_244.3 P63 BN63A4	127
6.0	172	3.5	223.2	12000	A353_223.2 S05 M05A4	130	A353_223.2 P63 BN63A4	131
6.1	171	1.5	221.3	6200	A203_221.3 S05 M05A4	122	A203_221.3 P63 BN63A4	123
6.2	167	2.2	216.6	9600	A303_216.6 S05 M05A4	126	A303_216.6 P63 BN63A4	127
6.8	154	1.6	199.2	6200	A203_199.2 S05 M05A4	122	A203_199.2 P63 BN63A4	123
6.8	153	2.3	198.5	9600	A303_198.5 S05 M05A4	126	A303_198.5 P63 BN63A4	127
7.6	138	2.5	178.5	9600	A303_178.5 S05 M05A4	126	A303_178.5 P63 BN63A4	127
7.6	138	1.8	178.3	6200	A203_178.3 S05 M05A4	122	A203_178.3 P63 BN63A4	123
8.3	126	1.9	163.4	6200	A203_163.4 S05 M05A4	122	A203_163.4 P63 BN63A4	123
8.4	125	2.7	161.4	9600	A303_161.4 S05 M05A4	126	A303_161.4 P63 BN63A4	127
9.0	116	2.8	150.7	9600	A303_150.7 S05 M05A4	126	A303_150.7 P63 BN63A4	127
9.2	113	2.0	146.1	6200	A203_146.1 S05 M05A4	122	A203_146.1 P63 BN63A4	123
9.8	106	3.0	137.4	9600	A303_137.4 S05 M05A4	126	A303_137.4 P63 BN63A4	127
10.5	100	2.2	129.1	6200	A203_129.1 S05 M05A4	122	A203_129.1 P63 BN63A4	123
11.2	93	2.3	120.5	6200	A203_120.5 S05 M05A4	122	A203_120.5 P63 BN63A4	123
11.2	93	3.2	120.5	9600	A303_120.5 S05 M05A4	126	A303_120.5 P63 BN63A4	127
12.4	84	2.4	109.2	6200	A203_109.2 S05 M05A4	122	A203_109.2 P63 BN63A4	123
14.6	74	2.7	92.3	6200	A202_92.3 S05 M05A4	122	A202_92.3 P63 BN63A4	123
14.7	73	1.4	91.6	4420	A052_91.6 S05 M05A4	115	A052_91.6 P63 BN63A4	115
14.7	73	1.8	91.6	5500	A102_91.6 S05 M05A4	118	A102_91.6 P63 BN63A4	119
16.9	64	3.3	79.9	6200	A202_79.9 S05 M05A4	122	A202_79.9 P63 BN63A4	123
17.7	61	1.6	76.4	4230	A052_76.4 S05 M05A4	115	A052_76.4 P63 BN63A4	115
17.7	61	2.5	76.4	5500	A102_76.4 S05 M05A4	118	A102_76.4 P63 BN63A4	119
20.5	53	1.9	65.9	4070	A052_65.9 S05 M05A4	115	A052_65.9 P63 BN63A4	115
20.5	53	2.8	65.9	5500	A102_65.9 S05 M05A4	118	A102_65.9 P63 BN63A4	119
23.0	47	2.1	58.6	3950	A052_58.6 S05 M05A4	115	A052_58.6 P63 BN63A4	115
23.0	47	3.2	58.6	5500	A102_58.6 S05 M05A4	118	A102_58.6 P63 BN63A4	119
26.3	41	2.4	51.3	3810	A052_51.3 S05 M05A4	115	A052_51.3 P63 BN63A4	115
29.7	36	2.8	45.4	3680	A052_45.4 S05 M05A4	115	A052_45.4 P63 BN63A4	115
33	33	3.1	40.9	3570	A052_40.9 S05 M05A4	115	A052_40.9 P63 BN63A4	115
38	28	3.6	35.1	3420	A052_35.1 S05 M05A4	115	A052_35.1 P63 BN63A4	115
42	26	3.9	32.2	3340	A052_32.2 S05 M05A4	115	A052_32.2 P63 BN63A4	115
47	23	4.4	28.6	3220	A052_28.6 S05 M05A4	115	A052_28.6 P63 BN63A4	115
53	20	4.9	25.5	3110	A052_25.5 S05 M05A4	115	A052_25.5 P63 BN63A4	115
57	19	5.3	23.8	3050	A052_23.8 S05 M05A4	115	A052_23.8 P63 BN63A4	115
62	17.3	5.8	13.9	2960	A052_13.9 S05 M05B6	115	A052_13.9 P63 BN63B6	115
63	17.1	5.9	21.4	2950	A052_21.4 S05 M05A4	115	A052_21.4 P63 BN63A4	115
73	14.8	6.7	18.6	2830	A052_18.6 S05 M05A4	115	A052_18.6 P63 BN63A4	115
82	13.1	7.6	16.4	2730	A052_16.4 S05 M05A4	115	A052_16.4 P63 BN63A4	115
90	11.9	8.4	9.6	2640	A052_9.6 S05 M05B6	115	A052_9.6 P63 BN63B6	115
97	11.1	9.0	13.9	2590	A052_13.9 S05 M05A4	115	A052_13.9 P63 BN63A4	115
110	9.8	10.2	12.3	2500	A052_12.3 S05 M05A4	115	A052_12.3 P63 BN63A4	115
121	8.9	11.2	7.2	2420	A052_7.2 S05 M05B6	115	A052_7.2 P63 BN63B6	115
128	8.4	11.9	10.6	2380	A052_10.6 S05 M05A4	115	A052_10.6 P63 BN63A4	115
140	7.7	13.0	9.6	2310	A052_9.6 S05 M05A4	115	A052_9.6 P63 BN63A4	115
159	6.8	14.7	8.5	2220	A052_8.5 S05 M05A4	115	A052_8.5 P63 BN63A4	115
187	5.8	17.4	7.2	2110	A052_7.2 S05 M05A4	115	A052_7.2 P63 BN63A4	115
213	5.1	19.8	6.3	2020	A052_6.3 S05 M05A4	115	A052_6.3 P63 BN63A4	115
247	4.4	21.8	5.5	1930	A052_5.5 S05 M05A4	115	A052_5.5 P63 BN63A4	115

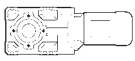



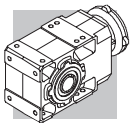

0.18 kW



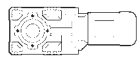

n ₂ min ⁻¹	M ₂ Nm	S	i	R _{n2} N			 IEC 	
0.52	2917	1.7	1715	50000	A704_1715 S1 M1SC6	150	A704_1715 P71 BN71A6	151
0.58	2649	3.0	1558	65000	A804_1558 S1 M1SC6	153	A804_1558 P71 BN71A6	154
0.67	2279	3.5	1340	65000	A804_1340 S1 M1SC6	153	A804_1340 P71 BN71A6	154
0.77	1989	2.5	1715	50000			A704_1715 P63 BN63B4	151
0.83	1836	2.7	1583	50000			A704_1583 P63 BN63B4	151
0.98	1561	3.2	1346	50000			A704_1346 P63 BN63B4	151
1.1	1441	3.5	1242	50000			A704_1242 P63 BN63B4	151
1.3	1186	2.4	697.3	30000	A604_697.3 S1 M1SC6	146	A604_697.3 P71 BN71A6	147
1.5	996	2.8	585.8	30000	A604_585.8 S1 M1SC6	146	A604_585.8 P71 BN71A6	147
1.7	902	1.7	778.2	20000			A504_778.2 P63 BN63B4	139
1.7	876	3.2	755.4	30000			A604_755.4 P63 BN63B4	147
1.9	821	1.8	707.9	20000			A504_707.9 P63 BN63B4	139
1.9	809	3.5	697.3	30000			A604_697.3 P63 BN63B4	147
2.1	732	2.0	631.2	20000			A504_631.2 P63 BN63B4	139
2.3	666	2.3	574.2	20000			A504_574.2 P63 BN63B4	139
2.5	614	2.4	529.5	20000			A504_529.5 P63 BN63B4	139
2.7	559	2.7	481.6	20000			A504_481.6 P63 BN63B4	139
3.0	518	2.9	446.8	20000			A504_446.8 P63 BN63B4	139
3.2	471	3.2	406.4	20000			A504_406.4 P63 BN63B4	139
3.4	466	1.0	393.2	12000	A353_393.2 S05 M05B4	130	A353_393.2 P63 BN63B4	131
3.5	447	1.9	376.8	15000	A413_376.8 S05 M05B4	134	A413_376.8 P63 BN63B4	135
3.6	424	3.5	365.6	20000			A504_365.6 P63 BN63B4	139
3.7	422	0.9	356.3	9600	A303_356.3 S05 M05B4	126	A303_356.3 P63 BN63B4	127
3.9	402	1.3	339.3	12000	A353_339.3 S05 M05B4	130	A353_339.3 P63 BN63B4	131
4.1	384	2.2	324.2	15000	A413_324.2 S05 M05B4	134	A413_324.2 P63 BN63B4	135
4.2	373	1.0	314.5	9600	A303_314.5 S05 M05B4	126	A303_314.5 P63 BN63B4	127
4.3	362	1.7	305.4	12000	A353_305.4 S05 M05B4	130	A353_305.4 P63 BN63B4	131
4.5	346	2.5	291.7	15000	A413_291.7 S05 M05B4	134	A413_291.7 P63 BN63B4	135
4.9	322	1.2	271.5	9600	A303_271.5 S05 M05B4	126	A303_271.5 P63 BN63B4	127
4.9	321	1.9	270.7	12000	A353_270.7 S05 M05B4	130	A353_270.7 P63 BN63B4	131
5.0	311	2.7	262.5	15000	A413_262.5 S05 M05B4	134	A413_262.5 P63 BN63B4	135
5.3	294	2.0	248.1	12000	A353_248.1 S05 M05B4	130	A353_248.1 P63 BN63B4	131
5.4	290	1.3	244.3	9600	A303_244.3 S05 M05B4	126	A303_244.3 P63 BN63B4	127
5.5	285	3.0	240.6	15000	A413_240.6 S05 M05B4	134	A413_240.6 P63 BN63B4	135
5.9	265	2.3	223.2	12000	A353_223.2 S05 M05B4	130	A353_223.2 P63 BN63B4	131
6.0	262	1.0	221.3	6200	A203_221.3 S05 M05B4	122	A203_221.3 P63 BN63B4	123
6.1	258	3.3	217.4	15000	A413_217.4 S05 M05B4	134	A413_217.4 P63 BN63B4	135
6.1	257	1.4	216.6	9600	A303_216.6 S05 M05B4	126	A303_216.6 P63 BN63B4	127
6.5	239	2.5	201.8	12000	A353_201.8 S05 M05B4	130	A353_201.8 P63 BN63B4	131
6.6	236	1.1	199.2	6200	A203_199.2 S05 M05B4	122	A203_199.2 P63 BN63B4	123
6.6	235	1.5	198.5	9600	A303_198.5 S05 M05B4	126	A303_198.5 P63 BN63B4	127
7.0	223	2.7	188.3	12000	A353_188.3 S05 M05B4	130	A353_188.3 P63 BN63B4	131
7.4	212	1.6	178.5	9600	A303_178.5 S05 M05B4	126	A303_178.5 P63 BN63B4	127
7.4	211	1.2	178.3	6200	A203_178.3 S05 M05B4	122	A203_178.3 P63 BN63B4	123
7.7	204	2.9	171.8	12000	A353_171.8 S05 M05B4	130	A353_171.8 P63 BN63B4	131
8.1	194	1.2	163.4	6200	A203_163.4 S05 M05B4	122	A203_163.4 P63 BN63B4	123
8.2	191	1.8	161.4	9600	A303_161.4 S05 M05B4	126	A303_161.4 P63 BN63B4	127
8.8	179	1.8	150.7	9600	A303_150.7 S05 M05B4	126	A303_150.7 P63 BN63B4	127
8.8	179	3.4	150.6	12000	A353_150.6 S05 M05B4	130	A353_150.6 P63 BN63B4	131
9.0	173	1.3	146.1	6200	A203_146.1 S05 M05B4	122	A203_146.1 P63 BN63B4	123
9.6	163	1.9	137.4	9600	A303_137.4 S05 M05B4	126	A303_137.4 P63 BN63B4	127
10.2	153	1.4	129.1	6200	A203_129.1 S05 M05B4	122	A203_129.1 P63 BN63B4	123
11.0	143	1.5	120.5	6200	A203_120.5 S05 M05B4	122	A203_120.5 P63 BN63B4	123
11.0	143	2.1	120.5	9600	A303_120.5 S05 M05B4	126	A303_120.5 P63 BN63B4	127
12.1	129	1.6	109.2	6200	A203_109.2 S05 M05B4	122	A203_109.2 P63 BN63B4	123
12.1	129	2.3	109.1	9600	A303_109.1 S05 M05B4	126	A303_109.1 P63 BN63B4	127
13.5	119	2.5	97.5	9600			A302_97.5 P63 BN63B4	127
14.3	113	1.8	92.3	6200	A202_92.3 S05 M05B4	122	A202_92.3 P63 BN63B4	123
14.4	112	0.9	91.6	4120	A052_91.6 S05 M05B4	115	A052_91.6 P63 BN63B4	115
14.4	112	1.2	91.6	5500	A102_91.6 S05 M05B4	118	A102_91.6 P63 BN63B4	119
15.2	106	3.0	86.7	9600			A302_86.7 P63 BN63B4	127
16.5	98	2.1	79.9	6200	A202_79.9 S05 M05B4	122	A202_79.9 P63 BN63B4	123
17.3	94	1.1	76.4	3980	A052_76.4 S05 M05B4	115	A052_76.4 P63 BN63B4	115
17.3	94	1.6	76.4	5500	A102_76.4 S05 M05B4	118	A102_76.4 P63 BN63B4	119
18.6	87	2.4	71.0	6200	A202_71.0 S05 M05B4	122	A202_71.0 P63 BN63B4	123
20.0	81	1.2	65.9	3860	A052_65.9 S05 M05B4	115	A052_65.9 P63 BN63B4	115



0.18 kW

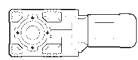

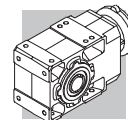

n₂ min ⁻¹	M₂ Nm	S	i	R_{n2} N				
20.0	81	1.9	65.9	5500	A102_65.9 S05 M05B4	118	A102_65.9 P63 BN63B4	119
20.9	77	3.2	63.1	6200	A202_63.1 S05 M05B4	122	A202_63.1 P63 BN63B4	123
22.5	72	1.4	58.6	3760	A052_58.6 S05 M05B4	115	A052_58.6 P63 BN63B4	115
22.5	72	2.1	58.6	5500	A102_58.6 S05 M05B4	118	A102_58.6 P63 BN63B4	119
25.8	63	1.6	51.3	3640	A052_51.3 S05 M05B4	115	A052_51.3 P63 BN63B4	115
25.8	63	2.4	51.3	5500	A102_51.3 S05 M05B4	118	A102_51.3 P63 BN63B4	119
29.1	56	1.8	45.4	3540	A052_45.4 S05 M05B4	115	A052_45.4 P63 BN63B4	115
29.1	56	2.7	45.4	5500	A102_45.4 S05 M05B4	118	A102_45.4 P63 BN63B4	119
32	50	2.0	40.9	3440	A052_40.9 S05 M05B4	115	A052_40.9 P63 BN63B4	115
32	50	3.0	40.9	5500	A102_40.9 S05 M05B4	118	A102_40.9 P63 BN63B4	119
38	43	2.3	35.1	3310	A052_35.1 S05 M05B4	115	A052_35.1 P63 BN63B4	115
38	43	3.5	35.1	5380	A102_35.1 S05 M05B4	118	A102_35.1 P63 BN63B4	119
41	39	2.5	32.2	3240	A052_32.2 S05 M05B4	115	A052_32.2 P63 BN63B4	115
46	35	2.9	28.6	3130	A052_28.6 S05 M05B4	115	A052_28.6 P63 BN63B4	115
52	31	3.2	25.5	3040	A052_25.5 S05 M05B4	115	A052_25.5 P63 BN63B4	115
56	29	3.4	23.8	2980	A052_23.8 S05 M05B4	115	A052_23.8 P63 BN63B4	115
62	26	3.8	21.4	2890	A052_21.4 S05 M05B4	115	A052_21.4 P63 BN63B4	115
71	23	4.4	18.6	2780	A052_18.6 S05 M05B4	115	A052_18.6 P63 BN63B4	115
80	20	5.0	16.4	2680	A052_16.4 S05 M05B4	115	A052_16.4 P63 BN63B4	115
95	17.1	5.9	13.9	2550	A052_13.9 S05 M05B4	115	A052_13.9 P63 BN63B4	115
107	15.1	6.6	12.3	2460	A052_12.3 S05 M05B4	115	A052_12.3 P63 BN63B4	115
125	12.9	7.7	10.6	2350	A052_10.6 S05 M05B4	115	A052_10.6 P63 BN63B4	115
137	11.8	8.5	9.6	2280	A052_9.6 S05 M05B4	115	A052_9.6 P63 BN63B4	115
142	11.4	8.8	6.3	2300	A052_6.3 S1 M1SC6	115	A052_6.3 P71 BN71A6	115
155	10.4	9.6	8.5	2200	A052_8.5 S05 M05B4	115	A052_8.5 P63 BN63B4	115
183	8.8	11.3	7.2	2090	A052_7.2 S05 M05B4	115	A052_7.2 P63 BN63B4	115
208	7.8	12.9	6.3	2010	A052_6.3 S05 M05B4	115	A052_6.3 P63 BN63B4	115
242	6.7	14.2	5.5	1920	A052_5.5 S05 M05B4	115	A052_5.5 P63 BN63B4	115
284	5.7	16.7	9.6	1830	A052_9.6 S05 M05A2	115	A052_9.6 P63 BN63A2	115
321	5.0	17.8	8.5	1770	A052_8.5 S05 M05A2	115	A052_8.5 P63 BN63A2	115
379	4.3	19.9	7.2	1670	A052_7.2 S05 M05A2	115	A052_7.2 P63 BN63A2	115
431	3.8	21.3	6.3	1610	A052_6.3 S05 M05A2	115	A052_6.3 P63 BN63A2	115
499	3.2	23.2	5.5	1530	A052_5.5 S05 M05A2	115	A052_5.5 P63 BN63A2	115

0.25 kW

n₂ min ⁻¹	M₂ Nm	S	i	R_{n2} N				
0.52	4051	1.2	1715	50000	A704_1715 S1 M1SD6	150	A704_1715 P71 BN71B6	151
0.58	3680	2.2	1558	65000	A804_1558 S1 M1SD6	153	A804_1558 P71 BN71B6	154
0.67	3165	2.5	1340	65000	A804_1340 S1 M1SD6	153	A804_1340 P71 BN71B6	154
0.80	2642	1.9	1715	50000			A704_1715 P71 BN71A4	151
0.87	2439	2.1	1583	50000			A704_1583 P71 BN71A4	151
0.89	2400	3.3	1558	65000			A804_1558 P71 BN71A4	154
1.0	2073	2.4	1346	50000			A704_1346 P71 BN71A4	151
1.1	1914	2.6	1242	50000			A704_1242 P71 BN71A4	151
1.2	1789	2.8	1161	50000			A704_1161 P71 BN71A4	151
1.3	1652	3.0	1072	50000			A704_1072 P71 BN71A4	151
1.5	1427	3.5	926.5	50000			A704_926.5 P71 BN71A4	151
1.8	1199	1.3	778.2	20000			A504_778.2 P71 BN71A4	139
1.8	1164	2.4	755.4	30000			A604_755.4 P71 BN71A4	147
1.9	1091	1.4	707.9	20000			A504_707.9 P71 BN71A4	139
2.0	1074	2.6	697.3	30000			A604_697.3 P71 BN71A4	147
2.2	978	2.9	634.6	30000			A604_634.6 P71 BN71A4	147
2.2	972	1.5	631.2	20000			A504_631.2 P71 BN71A4	139
2.4	902	3.1	585.8	30000			A604_585.8 P71 BN71A4	147
2.4	885	1.7	574.2	20000			A504_574.2 P71 BN71A4	139
2.5	835	3.4	542.0	30000			A604_542.0 P71 BN71A4	147
2.6	816	1.8	529.5	20000			A504_529.5 P71 BN71A4	139
2.9	742	2.0	481.6	20000			A504_481.6 P71 BN71A4	139
3.1	688	2.2	446.8	20000			A504_446.8 P71 BN71A4	139
3.4	626	2.4	406.4	20000			A504_406.4 P71 BN71A4	139
3.6	611	1.4	376.8	15000	A413_376.8 S05 M05C4	134	A413_376.8 P71 BN71A4	135





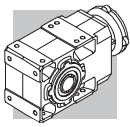

0.25 kW





n ₂ min ⁻¹	M ₂ Nm	S	i	R _{n2} N				
3.8	563	2.7	365.6	20000			A504_365.6 P71 BN71A4	139
3.9	550	0.9	339.3	12000	A353_339.3 S05 M05C4	130	A353_339.3 P71 BN71A4	131
4.1	526	1.6	324.2	15000	A413_324.2 S05 M05C4	134	A413_324.2 P71 BN71A4	135
4.1	512	2.9	332.6	20000			A504_332.6 P71 BN71A4	139
4.4	495	1.2	305.4	12000	A353_305.4 S05 M05C4	130	A353_305.4 P71 BN71A4	131
4.7	460	1.8	291.7	15000	A413_291.7 S05 M05C4	134	A413_291.7 P71 BN71A4	135
4.8	442	3.4	286.8	20000			A504_286.8 P71 BN71A4	139
4.9	440	0.9	271.5	9600	A303_271.5 S05 M05C4	126	A303_271.5 P71 BN71A4	127
5.0	439	1.4	270.7	12000	A353_270.7 S05 M05C4	130	A353_270.7 P71 BN71A4	131
5.1	426	2.0	262.5	15000	A413_262.5 S05 M05C4	134	A413_262.5 P71 BN71A4	135
5.4	403	1.5	248.1	12000	A353_248.1 S05 M05C4	130	A353_248.1 P71 BN71A4	131
5.6	385	1.0	244.3	9600	A303_244.3 S05 M05C4	126	A303_244.3 P71 BN71A4	127
5.7	379	2.2	240.6	15000	A413_240.6 S05 M05C4	134	A413_240.6 P71 BN71A4	135
6.0	362	1.7	223.2	12000	A353_223.2 S05 M05C4	130	A353_223.2 P71 BN71A4	131
6.2	353	2.4	217.4	15000	A413_217.4 S05 M05C4	134	A413_217.4 P71 BN71A4	135
6.2	351	1.0	216.6	9600	A303_216.6 S05 M05C4	126	A303_216.6 P71 BN71A4	127
6.6	327	1.8	201.8	12000	A353_201.8 S05 M05C4	130	A353_201.8 P71 BN71A4	131
7.0	313	1.1	198.5	9600	A303_198.5 S05 M05C4	126	A303_198.5 P71 BN71A4	127
7.0	311	2.7	197.5	15000	A413_197.5 S05 M05C4	134	A413_197.5 P71 BN71A4	135
7.1	306	2.0	188.3	12000	A353_188.3 S05 M05C4	130	A353_188.3 P71 BN71A4	131
7.3	299	2.8	184.4	15000	A413_184.4 S05 M05C4	134	A413_184.4 P71 BN71A4	135
7.5	290	1.2	178.5	9600	A303_178.5 S05 M05C4	126	A303_178.5 P71 BN71A4	127
7.8	279	2.2	171.8	12000	A353_171.8 S05 M05C4	130	A353_171.8 P71 BN71A4	131
8.4	257	0.9	163.4	6200	A203_163.4 S05 M05C4	122	A203_163.4 P71 BN71A4	123
8.5	254	1.3	161.4	9600	A303_161.4 S05 M05C4	126	A303_161.4 P71 BN71A4	127
8.9	244	1.4	150.7	9600	A303_150.7 S05 M05C4	126	A303_150.7 P71 BN71A4	127
8.9	244	2.5	150.6	12000	A353_150.6 S05 M05C4	130	A353_150.6 P71 BN71A4	131
9.2	237	1.0	146.1	6200	A203_146.1 S05 M05C4	122	A203_146.1 P71 BN71A4	123
9.8	221	2.6	136.3	12000	A353_136.3 S05 M05C4	130	A353_136.3 P71 BN71A4	131
10.0	216	1.5	137.4	9600	A303_137.4 S05 M05C4	126	A303_137.4 P71 BN71A4	127
10.7	203	1.1	129.1	6200	A203_129.1 S05 M05C4	122	A203_129.1 P71 BN71A4	123
11.1	196	1.1	120.5	6200	A203_120.5 S05 M05C4	122	A203_120.5 P71 BN71A4	123
11.1	195	1.5	120.5	9600	A303_120.5 S05 M05C4	126	A303_120.5 P71 BN71A4	127
11.5	190	3.0	116.9	12000	A353_116.9 S05 M05C4	130	A353_116.9 P71 BN71A4	131
12.6	172	1.2	109.2	6200	A203_109.2 S05 M05C4	122	A203_109.2 P71 BN71A4	123
12.7	172	1.7	109.1	9600	A303_109.1 S05 M05C4	126	A303_109.1 P71 BN71A4	127
12.7	171	3.1	105.5	12000	A353_105.5 S05 M05C4	130	A353_105.5 P71 BN71A4	131
14.2	159	1.9	97.5	9600			A302_97.5 P71 BN71A4	127
14.4	156	3.5	95.6	12000			A352_95.6 P71 BN71A4	131
14.5	155	1.3	92.3	6200	A202_92.3 S05 M05C4	122	A202_92.3 P71 BN71A4	123
15.9	141	2.3	86.7	9600			A302_86.7 P71 BN71A4	127
16.8	134	1.6	79.9	6200	A202_79.9 S05 M05C4	122	A202_79.9 P71 BN71A4	123
17.5	128	1.2	76.4	5500	A102_76.4 S05 M05C4	118	A102_76.4 P71 BN71A4	119
18.0	125	2.8	76.5	9600			A302_76.5 P71 BN71A4	127
19.4	116	1.8	71.0	6200	A202_71.0 S05 M05C4	122	A202_71.0 P71 BN71A4	123
20.3	110	0.9	65.9	3610	A052_65.9 S05 M05C4	115	A052_65.9 P71 BN71A4	115
20.3	110	1.4	65.9	5500	A102_65.9 S05 M05C4	118	A102_65.9 P71 BN71A4	119
21.2	106	2.3	63.1	6200	A202_63.1 S05 M05C4	122	A202_63.1 P71 BN71A4	123
22.9	98	1.0	58.6	3540	A052_58.6 S05 M05C4	115	A052_58.6 P71 BN71A4	115
23.5	95	1.6	58.6	5500	A102_58.6 S05 M05C4	118	A102_58.6 P71 BN71A4	119
25.0	90	2.8	53.7	6200	A202_53.7 S05 M05C4	122	A202_53.7 P71 BN71A4	123
26.1	86	1.2	51.3	3450	A052_51.3 S05 M05C4	115	A052_51.3 P71 BN71A4	115
26.1	86	1.7	51.3	5500	A102_51.3 S05 M05C4	118	A102_51.3 P71 BN71A4	119
28.6	79	3.2	48.3	6180	A202_48.3 S05 M05C4	122	A202_48.3 P71 BN71A4	123
29.5	76	1.3	45.4	3370	A052_45.4 S05 M05C4	115	A052_45.4 P71 BN71A4	115
29.5	76	2.0	45.4	5500	A102_45.4 S05 M05C4	118	A102_45.4 P71 BN71A4	119
33	68	1.5	40.9	3290	A052_40.9 S05 M05C4	115	A052_40.9 P71 BN71A4	115
34	66	2.3	40.9	5500	A102_40.9 S05 M05C4	118	A102_40.9 P71 BN71A4	119
38	59	1.7	35.1	3180	A052_35.1 S05 M05C4	115	A052_35.1 P71 BN71A4	115
38	59	2.5	35.1	5260	A102_35.1 S05 M05C4	118	A102_35.1 P71 BN71A4	119
42	54	1.9	32.2	3120	A052_32.2 S05 M05C4	115	A052_32.2 P71 BN71A4	115
43	52	2.9	32.2	5500	A102_32.2 S05 M05C4	118	A102_32.2 P71 BN71A4	119
47	48	2.1	28.6	3030	A052_28.6 S05 M05C4	115	A052_28.6 P71 BN71A4	115
47	48	3.1	28.6	4970	A102_28.6 S05 M05C4	118	A102_28.6 P71 BN71A4	119
53	43	2.3	25.5	2940	A052_25.5 S05 M05C4	115	A052_25.5 P71 BN71A4	115
56	40	2.5	23.8	2890	A052_23.8 S05 M05C4	115	A052_23.8 P71 BN71A4	115



0.25 kW



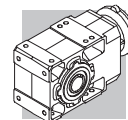

n₂ min ⁻¹	M₂ Nm	S	i	R_{n2} N				
63	36	2.8	21.4	2810	A052_21.4 S05 M05C4	115	A052_21.4 P71 BN71A4	115
72	31	3.2	18.6	2710	A052_18.6 S05 M05C4	115	A052_18.6 P71 BN71A4	115
84	27	3.7	16.4	2620	A052_16.4 S05 M05C4	115	A052_16.4 P71 BN71A4	115
99	23	4.4	13.9	2500	A052_13.9 S05 M05C4	115	A052_13.9 P71 BN71A4	115
112	20	5.0	12.3	2420	A052_12.3 S05 M05C4	115	A052_12.3 P71 BN71A4	115
131	17.2	5.8	10.6	2310	A052_10.6 S05 M05C4	115	A052_10.6 P71 BN71A4	115
144	15.7	6.4	9.6	2260	A052_9.6 S05 M05C4	115	A052_9.6 P71 BN71A4	115
162	13.9	7.2	8.5	2180	A052_8.5 S05 M05C4	115	A052_8.5 P71 BN71A4	115
191	11.7	8.5	7.2	2070	A052_7.2 S05 M05C4	115	A052_7.2 P71 BN71A4	115
218	10.3	9.7	6.3	1990	A052_6.3 S05 M05C4	115	A052_6.3 P71 BN71A4	115
252	8.9	10.7	5.5	1900	A052_5.5 S05 M05C4	115	A052_5.5 P71 BN71A4	115
285	7.9	12.1	9.6	1820	A052_9.6 S05 M05B2	115	A052_9.6 P63 BN63B2	115
322	7.0	12.9	8.5	1750	A052_8.5 S05 M05B2	115	A052_8.5 P63 BN63B2	115
380	5.9	14.4	7.2	1660	A052_7.2 S05 M05B2	115	A052_7.2 P63 BN63B2	115
433	5.2	15.4	6.3	1590	A052_6.3 S05 M05B2	115	A052_6.3 P63 BN63B2	115
501	4.5	16.7	5.5	1520	A052_5.5 S05 M05B2	115	A052_5.5 P63 BN63B2	115

0.37 kW

n₂ min ⁻¹	M₂ Nm	S	i	R_{n2} N				
0.56	5644	2.5	1632	75000	A904_1632 S1 M1LA6	156	A904_1632 P80 BN80A6	157
0.63	4972	1.6	1438	65000	A804_1438 S1 M1LA6	153	A804_1438 P80 BN80A6	154
0.74	4226	3.3	1222	75000	A904_1222 S1 M1LA6	156	A904_1222 P80 BN80A6	157
0.80	3939	1.3	1715	50000	A704_1715 S1 M1SD4	150	A704_1715 P71 BN71B4	151
0.87	3636	1.4	1583	50000	A704_1583 S1 M1SD4	150	A704_1583 P71 BN71B4	151
0.88	3577	2.2	1558	65000	A804_1558 S1 M1SD4	153	A804_1558 P71 BN71B4	154
0.95	3302	2.4	1438	65000	A804_1438 S1 M1SD4	153	A804_1438 P71 BN71B4	154
1.0	3091	1.6	1346	50000	A704_1346 S1 M1SD4	150	A704_1346 P71 BN71B4	151
1.0	3077	2.6	1340	65000	A804_1340 S1 M1SD4	153	A804_1340 P71 BN71B4	154
1.1	2853	1.8	1242	50000	A704_1242 S1 M1SD4	150	A704_1242 P71 BN71B4	151
1.1	2841	2.8	1237	65000	A804_1237 S1 M1SD4	153	A804_1237 P71 BN71B4	154
1.2	2668	1.9	1161	50000	A704_1161 S1 M1SD4	150	A704_1161 P71 BN71B4	151
1.3	2492	3.2	1085	65000	A804_1085 S1 M1SD4	153	A804_1085 P71 BN71B4	154
1.3	2462	2.0	1072	50000	A704_1072 S1 M1SD4	150	A704_1072 P71 BN71B4	151
1.4	2300	3.5	1001	65000	A804_1001 S1 M1SD4	153	A804_1001 P71 BN71B4	154
1.5	2128	2.3	926.5	50000	A704_926.5 S1 M1SD4	150	A704_926.5 P71 BN71B4	151
1.6	1964	2.5	855.3	50000	A704_855.3 S1 M1SD4	150	A704_855.3 P71 BN71B4	151
1.8	1754	2.8	763.9	50000	A704_763.9 S1 M1SD4	150	A704_763.9 P71 BN71B4	151
1.8	1735	1.6	755.4	30000	A604_755.4 S1 M1SD4	146	A604_755.4 P71 BN71B4	147
1.9	1626	0.9	707.9	20000	A504_707.9 S1 M1SD4	138	A504_707.9 P71 BN71B4	139
1.9	1619	3.1	705.1	50000	A704_705.1 S1 M1SD4	150	A704_705.1 P71 BN71B4	151
2.0	1601	1.7	697.3	30000	A604_697.3 S1 M1SD4	146	A604_697.3 P71 BN71B4	147
2.1	1481	3.4	644.6	50000	A704_644.6 S1 M1SD4	150	A704_644.6 P71 BN71B4	151
2.2	1457	1.9	634.6	30000	A604_634.6 S1 M1SD4	146	A604_634.6 P71 BN71B4	147
2.2	1450	1.0	631.2	20000	A504_631.2 S1 M1SD4	138	A504_631.2 P71 BN71B4	139
2.3	1345	2.1	585.8	30000	A604_585.8 S1 M1SD4	146	A604_585.8 P71 BN71B4	147
2.4	1319	1.1	574.2	20000	A504_574.2 S1 M1SD4	138	A504_574.2 P71 BN71B4	139
2.5	1245	2.2	542.0	30000	A604_542.0 S1 M1SD4	146	A604_542.0 P71 BN71B4	147
2.6	1216	1.2	529.5	20000	A504_529.5 S1 M1SD4	138	A504_529.5 P71 BN71B4	139
2.7	1149	2.4	500.3	30000	A604_500.3 S1 M1SD4	146	A604_500.3 P71 BN71B4	147
2.8	1106	1.4	481.6	20000	A504_481.6 S1 M1SD4	138	A504_481.6 P71 BN71B4	139
3.1	1026	1.5	446.8	20000	A504_446.8 S1 M1SD4	138	A504_446.8 P71 BN71B4	139
3.1	1007	2.8	438.4	30000	A604_438.4 S1 M1SD4	146	A604_438.4 P71 BN71B4	147
3.4	933	1.6	406.4	20000	A504_406.4 S1 M1SD4	138	A504_406.4 P71 BN71B4	139
3.4	929	3.0	404.7	30000	A604_404.7 S1 M1SD4	146	A604_404.7 P71 BN71B4	147
3.6	885	1.0	376.8	15000	A413_376.8 S1 M1SD4	134	A413_376.8 P71 BN71B4	135
3.7	840	1.8	365.6	20000	A504_365.6 S1 M1SD4	138	A504_365.6 P71 BN71B4	139
3.9	807	3.5	351.2	30000	A604_351.2 S1 M1SD4	146	A604_351.2 P71 BN71B4	147
4.1	764	2.0	332.6	20000	A504_332.6 S1 M1SD4	138	A504_332.6 P71 BN71B4	139
4.2	761	1.1	324.2	15000	A413_324.2 S1 M1SD4	134	A413_324.2 P71 BN71B4	135
4.7	685	1.2	291.7	15000	A413_291.7 S1 M1SD4	134	A413_291.7 P71 BN71B4	135
4.8	659	2.3	286.8	20000	A504_286.8 S1 M1SD4	138	A504_286.8 P71 BN71B4	139

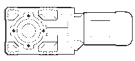



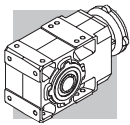

0.37 kW





n ₂ min ⁻¹	M ₂ Nm	S	i	R _{n2} N				
5.1	636	0.9	270.7	12000	A353_270.7 S1 M1SD4	130	A353_270.7 P71 BN71B4	131
5.2	616	1.4	262.5	15000	A413_262.5 S1 M1SD4	134	A413_262.5 P71 BN71B4	135
5.3	599	2.5	260.9	20000	A504_260.9 S1 M1SD4	138	A504_260.9 P71 BN71B4	139
5.5	583	1.0	248.1	12000	A353_248.1 S1 M1SD4	130	A353_248.1 P71 BN71B4	131
5.7	565	1.5	240.6	15000	A413_240.6 S1 M1SD4	134	A413_240.6 P71 BN71B4	135
5.9	533	2.8	232.0	20000	A504_232.0 S1 M1SD4	138	A504_232.0 P71 BN71B4	139
6.1	524	1.1	223.2	12000	A353_223.2 S1 M1SD4	130	A353_223.2 P71 BN71B4	131
6.3	511	1.7	217.4	15000	A413_217.4 S1 M1SD4	134	A413_217.4 P71 BN71B4	135
6.5	485	3.1	211.0	20000	A504_211.0 S1 M1SD4	138	A504_211.0 P71 BN71B4	139
6.8	474	1.3	201.8	12000	A353_201.8 S1 M1SD4	130	A353_201.8 P71 BN71B4	131
6.9	464	1.8	197.5	15000	A413_197.5 S1 M1SD4	134	A413_197.5 P71 BN71B4	135
7.2	448	3.4	190.6	20000	A503_190.6 S1 M1SD4	138	A503_190.6 P71 BN71B4	139
7.3	442	1.4	188.3	12000	A353_188.3 S1 M1SD4	130	A353_188.3 P71 BN71B4	131
7.4	433	2.0	184.4	15000	A413_184.4 S1 M1SD4	134	A413_184.4 P71 BN71B4	135
8.0	403	1.5	171.8	12000	A353_171.8 S1 M1SD4	130	A353_171.8 P71 BN71B4	131
9.1	354	0.9	150.7	9600	A303_150.7 S1 M1SD4	126	A303_150.7 P71 BN71B4	127
9.1	354	1.7	150.6	12000	A353_150.6 S1 M1SD4	130	A353_150.6 P71 BN71B4	131
9.3	345	2.5	146.9	15000	A413_146.9 S1 M1SD4	134	A413_146.9 P71 BN71B4	135
10.0	323	1.0	137.4	9600	A303_137.4 S1 M1SD4	126	A303_137.4 P71 BN71B4	127
10.0	320	1.8	136.3	12000	A353_136.3 S1 M1SD4	130	A353_136.3 P71 BN71B4	131
11.4	283	1.1	120.5	9600	A303_120.5 S1 M1SD4	126	A303_120.5 P71 BN71B4	127
11.7	275	2.0	116.9	12000	A353_116.9 S1 M1SD4	130	A353_116.9 P71 BN71B4	131
11.8	272	3.1	115.9	15000	A413_115.9 S1 M1SD4	134	A413_115.9 P71 BN71B4	135
12.6	256	1.2	109.1	9600	A303_109.1 S1 M1SD4	126	A303_109.1 P71 BN71B4	127
13.0	248	2.1	105.5	12000	A353_105.5 S1 M1SD4	130	A353_105.5 P71 BN71B4	131
14.1	237	1.3	97.5	9600	A302_97.5 S1 M1SD4	126	A302_97.5 P71 BN71B4	127
14.3	232	2.3	95.6	12000	A352_95.6 S1 M1SD4	130	A352_95.6 P71 BN71B4	131
15.8	210	1.5	86.7	9600	A302_86.7 S1 M1SD4	126	A302_86.7 P71 BN71B4	127
16.6	200	3.0	82.5	12000	A352_82.5 S1 M1SD4	130	A352_82.5 P71 BN71B4	131
17.2	194	1.1	79.9	6200	A202_79.9 S1 M1SD4	122	A202_79.9 P71 BN71B4	123
17.9	186	1.9	76.5	9600	A302_76.5 S1 M1SD4	126	A302_76.5 P71 BN71B4	127
18.4	180	3.3	74.3	12000	A352_74.3 S1 M1SD4	130	A352_74.3 P71 BN71B4	131
19.3	172	1.2	71.0	6200	A202_71.0 S1 M1SD4	122	A202_71.0 P71 BN71B4	123
20.7	160	2.4	66.0	9350	A302_66.0 S1 M1SD4	126	A302_66.0 P71 BN71B4	127
20.8	160	0.9	65.9	5500	A102_65.9 S1 M1SD4	118	A102_65.9 P71 BN71B4	119
21.7	153	1.6	63.1	6200	A202_63.1 S1 M1SD4	122	A202_63.1 P71 BN71B4	123
23.1	144	2.8	59.4	9080	A302_59.4 S1 M1SD4	126	A302_59.4 P71 BN71B4	127
23.4	142	1.1	58.6	5500	A102_58.6 S1 M1SD4	118	A102_58.6 P71 BN71B4	119
25.5	130	1.9	53.7	6090	A202_53.7 S1 M1SD4	122	A202_53.7 P71 BN71B4	123
26.0	128	3.2	52.7	8790	A302_52.7 S1 M1SD4	126	A302_52.7 P71 BN71B4	127
26.7	124	1.2	51.3	5490	A102_51.3 S1 M1SD4	118	A102_51.3 P71 BN71B4	119
28.4	117	2.1	48.3	5940	A202_48.3 S1 M1SD4	122	A202_48.3 P71 BN71B4	123
28.4	117	3.5	48.3	8580	A302_48.3 S1 M1SD4	126	A302_48.3 P71 BN71B4	127
30	110	0.9	45.4	3060	A052_45.4 S1 M1SD4	115	A052_45.4 P71 BN71B4	115
30	110	1.4	45.4	5350	A102_45.4 S1 M1SD4	118	A102_45.4 P71 BN71B4	119
32	105	2.4	43.2	5780	A202_43.2 S1 M1SD4	122	A202_43.2 P71 BN71B4	123
34	99	1.0	40.9	3020	A052_40.9 S1 M1SD4	115	A052_40.9 P71 BN71B4	115
34	99	1.5	40.9	5500	A102_40.9 S1 M1SD4	118	A102_40.9 P71 BN71B4	119
35	96	2.6	39.6	5650	A202_39.6 S1 M1SD4	122	A202_39.6 P71 BN71B4	123
39	86	2.9	35.4	5480	A202_35.4 S1 M1SD4	122	A202_35.4 P71 BN71B4	123
39	85	1.2	35.1	2950	A052_35.1 S1 M1SD4	115	A052_35.1 P71 BN71B4	115
39	85	1.8	35.1	5040	A102_35.1 S1 M1SD4	118	A102_35.1 P71 BN71B4	119
43	78	1.3	32.2	2900	A052_32.2 S1 M1SD4	115	A052_32.2 P71 BN71B4	115
43	78	1.9	32.2	5500	A102_32.2 S1 M1SD4	118	A102_32.2 P71 BN71B4	119
44	76	3.3	31.3	5310	A202_31.3 S1 M1SD4	122	A202_31.3 P71 BN71B4	123
47	71	3.5	29.2	5210	A202_29.2 S1 M1SD4	122	A202_29.2 P71 BN71B4	123
48	69	1.4	28.6	2840	A052_28.6 S1 M1SD4	115	A052_28.6 P71 BN71B4	115
48	69	2.2	28.6	4790	A102_28.6 S1 M1SD4	118	A102_28.6 P71 BN71B4	119
54	62	1.6	25.5	2770	A052_25.5 S1 M1SD4	115	A052_25.5 P71 BN71B4	115
54	62	2.4	25.5	5500	A102_25.5 S1 M1SD4	118	A102_25.5 P71 BN71B4	119
58	58	1.7	23.8	2730	A052_23.8 S1 M1SD4	115	A052_23.8 P71 BN71B4	115
58	58	2.6	23.8	4570	A102_23.8 S1 M1SD4	118	A102_23.8 P71 BN71B4	119
64	52	1.9	21.4	2670	A052_21.4 S1 M1SD4	115	A052_21.4 P71 BN71B4	115
64	52	2.9	21.4	5270	A102_21.4 S1 M1SD4	118	A102_21.4 P71 BN71B4	119
74	45	2.2	18.6	2590	A052_18.6 S1 M1SD4	115	A052_18.6 P71 BN71B4	115
74	45	3.3	18.6	4270	A102_18.6 S1 M1SD4	118	A102_18.6 P71 BN71B4	119



0.37 kW



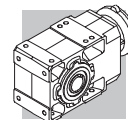

n ₂ min ⁻¹	M ₂ Nm	S	i	R _{n2} N				
83	40	2.5	16.4	2510	A052_16.4 S1 M1SD4	115	A052_16.4 P71 BN71B4	115
98	34	3.0	13.9	2410	A052_13.9 S1 M1SD4	115	A052_13.9 P71 BN71B4	115
111	30	3.3	12.3	2350	A052_12.3 S1 M1SD4	115	A052_12.3 P71 BN71B4	115
130	26	3.9	10.6	2240	A052_10.6 S1 M1SD4	115	A052_10.6 P71 BN71B4	115
142	23	4.3	9.6	2190	A052_9.6 S1 M1SD4	115	A052_9.6 P71 BN71B4	115
161	21	4.8	8.5	2120	A052_8.5 S1 M1SD4	115	A052_8.5 P71 BN71B4	115
190	17.5	5.7	7.2	2030	A052_7.2 S1 M1SD4	115	A052_7.2 P71 BN71B4	115
216	15.4	6.5	6.3	1950	A052_6.3 S1 M1SD4	115	A052_6.3 P71 BN71B4	115
228	14.6	6.8	12.3	1920	A052_12.3 S05 M05C2	115	A052_12.3 P71 BN71A2	115
251	13.3	7.2	5.5	1870	A052_5.5 S1 M1SD4	115	A052_5.5 P71 BN71B4	115
265	12.5	6.4	10.6	1830	A052_10.6 S05 M05C2	115	A052_10.6 P71 BN71A2	115
291	11.4	8.3	9.6	1790	A052_9.6 S05 M05C2	115	A052_9.6 P71 BN71A2	115
331	10.0	9.0	8.5	1720	A052_8.5 S05 M05C2	115	A052_8.5 P71 BN71A2	115
388	8.6	9.9	7.2	1640	A052_7.2 S05 M05C2	115	A052_7.2 P71 BN71A2	115
445	7.5	10.7	6.3	1570	A052_6.3 S05 M05C2	115	A052_6.3 P71 BN71A2	115
512	6.5	11.6	5.5	1500	A052_5.5 S05 M05C2	115	A052_5.5 P71 BN71A2	115

0.55 kW

n ₂ min ⁻¹	M ₂ Nm	S	i	R _{n2} N				
0.56	8299	1.7	1632	75000	A904_1632 S2 M2SA6	156	A904_1632 P80 BN80B6	157
0.64	7310	1.1	1438	65000	A804_1438 S2 M2SA6	153	A804_1438 P80 BN80B6	154
0.75	6213	2.3	1222	75000	A904_1222 S2 M2SA6	156	A904_1222 P80 BN80B6	157
0.80	5813	0.9	1715	50000	A704_1715 S1 M1LA4	150	A704_1715 P80 BN80A4	151
0.85	5532	2.5	1632	75000	A904_1632 S1 M1LA4	156	A904_1632 P80 BN80A4	157
0.87	5365	0.9	1583	50000	A704_1583 S1 M1LA4	150	A704_1583 P80 BN80A4	151
0.89	5279	1.5	1558	65000	A804_1558 S1 M1LA4	153	A804_1558 P80 BN80A4	154
0.92	5070	2.8	1507	75000	A904_1507 S1 M1LA4	156	A904_1507 P80 BN80A4	157
0.96	4873	1.6	1438	65000	A804_1438 S1 M1LA4	153	A804_1438 P80 BN80A4	154
1.0	4561	1.1	1346	50000	A704_1346 S1 M1LA4	150	A704_1346 P80 BN80A4	151
1.0	4541	1.8	1340	65000	A804_1340 S1 M1LA4	153	A804_1340 P80 BN80A4	154
1.0	4455	3.1	1324	75000	A904_1324 S1 M1LA4	156	A904_1324 P80 BN80A4	157
1.1	4211	1.2	1242	50000	A704_1242 S1 M1LA4	150	A704_1242 P80 BN80A4	151
1.1	4192	1.9	1237	65000	A804_1237 S1 M1LA4	153	A804_1237 P80 BN80A4	154
1.1	4112	3.4	1222	75000	A904_1222 S1 M1LA4	156	A904_1222 P80 BN80A4	157
1.2	3937	1.3	1161	50000	A704_1161 S1 M1LA4	150	A704_1161 P80 BN80A4	151
1.3	3677	2.2	1085	65000	A804_1085 S1 M1LA4	153	A804_1085 P80 BN80A4	154
1.3	3634	1.4	1072	50000	A704_1072 S1 M1LA4	150	A704_1072 P80 BN80A4	151
1.4	3394	2.4	1001	65000	A804_1001 S1 M1LA4	153	A804_1001 P80 BN80A4	154
1.5	3140	1.6	926.5	50000	A704_926.5 S1 M1LA4	150	A704_926.5 P80 BN80A4	151
1.5	3046	2.6	898.7	65000	A804_898.7 S1 M1LA4	153	A804_898.7 P80 BN80A4	154
1.6	2899	1.7	855.3	50000	A704_855.3 S1 M1LA4	150	A704_855.3 P80 BN80A4	151
1.7	2811	2.8	829.5	65000	A804_829.5 S1 M1LA4	153	A804_829.5 P80 BN80A4	154
1.8	2589	1.9	763.9	50000	A704_763.9 S1 M1LA4	150	A704_763.9 P80 BN80A4	151
1.8	2583	3.1	762.1	65000	A804_762.1 S1 M1LA4	153	A804_762.1 P80 BN80A4	154
1.8	2560	1.1	755.4	30000	A604_755.4 S1 M1LA4	146	A604_755.4 P80 BN80A4	147
2.0	2390	2.1	705.1	50000	A704_705.1 S1 M1LA4	150	A704_705.1 P80 BN80A4	151
2.0	2384	3.4	703.5	65000	A804_703.5 S1 M1LA4	153	A804_703.5 P80 BN80A4	154
2.0	2363	1.2	697.3	30000	A604_697.3 S1 M1LA4	146	A604_697.3 P80 BN80A4	147
2.1	2185	2.3	644.6	50000	A704_644.6 S1 M1LA4	150	A704_644.6 P80 BN80A4	151
2.2	2151	1.3	634.6	30000	A604_634.6 S1 M1LA4	146	A604_634.6 P80 BN80A4	147
2.3	2017	2.5	595.0	50000	A704_595.0 S1 M1LA4	150	A704_595.0 P80 BN80A4	151
2.4	1985	1.4	585.8	30000	A604_585.8 S1 M1LA4	146	A604_585.8 P80 BN80A4	147
2.5	1837	1.5	542.0	30000	A604_542.0 S1 M1LA4	146	A604_542.0 P80 BN80A4	147
2.7	1747	2.9	515.4	50000	A704_515.4 S1 M1LA4	150	A704_515.4 P80 BN80A4	151
2.8	1696	1.7	500.3	30000	A604_500.3 S1 M1LA4	146	A604_500.3 P80 BN80A4	147
2.9	1632	0.9	481.6	20000	A504_481.6 S1 M1LA4	138	A504_481.6 P80 BN80A4	139
2.9	1612	3.1	475.8	50000	A704_475.8 S1 M1LA4	150	A704_475.8 P80 BN80A4	151
3.1	1514	1.0	446.8	20000	A504_446.8 S1 M1LA4	138	A504_446.8 P80 BN80A4	139
3.1	1486	1.9	438.4	30000	A604_438.4 S1 M1LA4	146	A604_438.4 P80 BN80A4	147
3.4	1378	1.1	406.4	20000	A504_406.4 S1 M1LA4	138	A504_406.4 P80 BN80A4	139
3.4	1372	2.0	404.7	30000	A604_404.7 S1 M1LA4	146	A604_404.7 P80 BN80A4	147





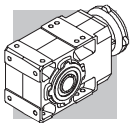

0.55 kW



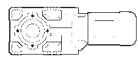

n ₂ min ⁻¹	M ₂ Nm	S	i	R _{n2} N			 IEC 	
3.8	1239	1.2	365.6	20000	A504_365.6 S1 M1LA4	138	A504_365.6 P80 BN80A4	139
3.9	1190	2.4	351.2	30000	A604_351.2 S1 M1LA4	146	A604_351.2 P80 BN80A4	147
4.1	1127	1.3	332.6	20000	A504_332.6 S1 M1LA4	138	A504_332.6 P80 BN80A4	139
4.3	1099	2.5	324.2	30000	A604_324.2 S1 M1LA4	146	A604_324.2 P80 BN80A4	147
4.8	972	1.5	286.8	20000	A504_286.8 S1 M1LA4	138	A504_286.8 P80 BN80A4	139
4.8	970	2.9	286.3	30000	A604_286.3 S1 M1LA4	146	A604_286.3 P80 BN80A4	147
5.2	896	3.1	264.3	30000	A604_264.3 S1 M1LA4	146	A604_264.3 P80 BN80A4	147
5.3	910	0.9	262.5	15000	A413_262.5 S1 M1LA4	134	A413_262.5 P80 BN80A4	135
5.3	884	1.7	260.9	20000	A504_260.9 S1 M1LA4	138	A504_260.9 P80 BN80A4	139
5.7	834	1.0	240.6	15000	A413_240.6 S1 M1LA4	134	A413_240.6 P80 BN80A4	135
5.9	786	1.9	232.0	20000	A504_232.0 S1 M1LA4	138	A504_232.0 P80 BN80A4	139
6.3	753	1.1	217.4	15000	A413_217.4 S1 M1LA4	134	A413_217.4 P80 BN80A4	135
6.5	715	2.1	211.0	20000	A504_211.0 S1 M1LA4	138	A504_211.0 P80 BN80A4	139
7.0	685	1.2	197.5	15000	A413_197.5 S1 M1LA4	134	A413_197.5 P80 BN80A4	135
7.1	673	3.0	194.2	30000	A553_194.2 S1 M1LA4	142	A553_194.2 P80 BN80A4	142
7.2	660	2.3	190.6	20000	A503_190.6 S1 M1LA4	138	A503_190.6 P80 BN80A4	139
7.3	653	0.9	188.3	12000	A353_188.3 S1 M1LA4	130	A353_188.3 P80 BN80A4	131
7.5	639	1.3	184.4	15000	A413_184.4 S1 M1LA4	134	A413_184.4 P80 BN80A4	135
7.9	607	3.3	175.0	30000	A553_175.0 S1 M1LA4	142	A553_175.0 P80 BN80A4	142
8.0	601	2.5	173.4	20000	A503_173.4 S1 M1LA4	138	A503_173.4 P80 BN80A4	139
8.0	595	1.0	171.8	12000	A353_171.8 S1 M1LA4	130	A353_171.8 P80 BN80A4	131
9.0	532	2.8	154.6	20000	A503_154.6 S1 M1LA4	138	A503_154.6 P80 BN80A4	139
9.2	522	1.1	150.6	12000	A353_150.6 S1 M1LA4	130	A353_150.6 P80 BN80A4	131
9.4	509	1.7	146.9	15000	A413_146.9 S1 M1LA4	134	A413_146.9 P80 BN80A4	135
9.9	484	3.1	140.6	20000	A503_140.6 S1 M1LA4	138	A503_140.6 P80 BN80A4	139
10.1	472	1.2	136.3	12000	A353_136.3 S1 M1LA4	130	A353_136.3 P80 BN80A4	131
10.7	446	3.4	129.7	20000	A503_129.7 S1 M1LA4	138	A503_129.7 P80 BN80A4	139
11.8	405	1.4	116.9	12000	A353_116.9 S1 M1LA4	130	A353_116.9 P80 BN80A4	131
11.9	402	2.1	115.9	15000	A413_115.9 S1 M1LA4	134	A413_115.9 P80 BN80A4	135
13.1	366	1.4	105.5	12000	A353_105.5 S1 M1LA4	130	A353_105.5 P80 BN80A4	131
14.2	349	0.9	97.5	9600			A302_97.5 P80 BN80A4	127
14.4	342	1.6	95.6	12000	A352_95.6 S1 M1LA4	130	A352_95.6 P80 BN80A4	131
14.9	321	2.5	92.8	15000	A413_92.8 S1 M1LA4	134	A413_92.8 P80 BN80A4	135
15.9	310	1.0	86.7	9420			A302_86.7 P80 BN80A4	127
16.7	295	2.0	82.5	12000	A352_82.5 S1 M1LA4	130	A352_82.5 P80 BN80A4	131
17.4	284	3.0	79.2	15000	A412_79.2 S1 M1LA4	134	A412_79.2 P80 BN80A4	135
18.0	274	1.3	76.5	9180	A302_76.5 S1 M1LA4	126	A302_76.5 P80 BN80A4	127
18.6	266	2.3	74.3	12000	A352_74.3 S1 M1LA4	130	A352_74.3 P80 BN80A4	131
19.4	255	3.3	71.3	15000	A412_71.3 S1 M1LA4	134	A412_71.3 P80 BN80A4	135
20.9	236	1.6	66.0	8880	A302_66.0 S1 M1LA4	126	A302_66.0 P80 BN80A4	127
21.0	236	2.5	65.8	12000	A352_65.8 S1 M1LA4	130	A352_65.8 P80 BN80A4	131
21.9	226	1.1	63.1	5840	A202_63.1 S1 M1LA4	122	A202_63.1 P80 BN80A4	123
22.9	216	2.8	60.4	12000	A352_60.4 S1 M1LA4	130	A352_60.4 P80 BN80A4	131
23.2	213	1.9	59.4	8660	A302_59.4 S1 M1LA4	126	A302_59.4 P80 BN80A4	127
25.4	194	3.1	54.3	12000	A352_54.3 S1 M1LA4	130	A352_54.3 P80 BN80A4	131
25.7	192	1.3	53.7	5670	A202_53.7 S1 M1LA4	122	A202_53.7 P80 BN80A4	123
26.2	189	2.2	52.7	8410	A302_52.7 S1 M1LA4	126	A302_52.7 P80 BN80A4	127
28.1	176	3.4	49.1	12000	A352_49.1 S1 M1LA4	130	A352_49.1 P80 BN80A4	131
28.6	173	1.4	48.3	5560	A202_48.3 S1 M1LA4	122	A202_48.3 P80 BN80A4	123
28.6	173	2.4	48.3	8230	A302_48.3 S1 M1LA4	126	A302_48.3 P80 BN80A4	127
30	163	0.9	45.4	4910	A102_45.4 S1 M1LA4	118	A102_45.4 P80 BN80A4	119
32	155	2.6	43.4	8010	A302_43.4 S1 M1LA4	126	A302_43.4 P80 BN80A4	127
32	155	1.6	43.2	5440	A202_43.2 S1 M1LA4	122	A202_43.2 P80 BN80A4	123
34	146	1.0	40.9	5500	A102_40.9 S1 M1LA4	118	A102_40.9 P80 BN80A4	119
35	142	1.8	39.6	5340	A202_39.6 S1 M1LA4	122	A202_39.6 P80 BN80A4	123
35	141	2.9	39.3	7800	A302_39.3 S1 M1LA4	126	A302_39.3 P80 BN80A4	127
38	131	3.1	36.6	7660	A302_36.6 S1 M1LA4	126	A302_36.6 P80 BN80A4	127
39	127	2.0	35.4	5200	A202_35.4 S1 M1LA4	122	A202_35.4 P80 BN80A4	123
39	126	1.2	35.1	4700	A102_35.1 S1 M1LA4	118	A102_35.1 P80 BN80A4	119
41	120	3.4	33.4	7480	A302_33.4 S1 M1LA4	126	A302_33.4 P80 BN80A4	127
43	115	1.3	32.2	5490	A102_32.2 S1 M1LA4	118	A102_32.2 P80 BN80A4	119
44	112	2.2	31.3	5060	A202_31.3 S1 M1LA4	122	A202_31.3 P80 BN80A4	123
47	105	2.4	29.2	4970	A202_29.2 S1 M1LA4	122	A202_29.2 P80 BN80A4	123
48	102	1.0	28.6	2550	A052_28.6 S1 M1LA4	115	A052_28.6 P80 BN80A4	115
48	102	1.5	28.6	4510	A102_28.6 S1 M1LA4	118	A102_28.6 P80 BN80A4	119
52	95	2.6	26.5	4850	A202_26.5 S1 M1LA4	122	A202_26.5 P80 BN80A4	123



0.55 kW



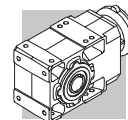

n₂ min ⁻¹	M₂ Nm	S	i	R_{n2} N				
54	91	1.1	25.5	2510	A052_25.5 S1 M1LA4	115	A052_25.5 P80 BN80A4	115
54	91	1.6	25.5	5230	A102_25.5 S1 M1LA4	118	A102_25.5 P80 BN80A4	119
58	85	1.2	23.8	2490	A052_23.8 S1 M1LA4	115	A052_23.8 P80 BN80A4	115
58	85	1.8	23.8	4330	A102_23.8 S1 M1LA4	118	A102_23.8 P80 BN80A4	119
60	83	3.0	23.1	4690	A202_23.1 S1 M1LA4	122	A202_23.1 P80 BN80A4	123
65	76	1.3	21.4	2450	A052_21.4 S1 M1LA4	115	A052_21.4 P80 BN80A4	115
65	76	2.0	21.4	5020	A102_21.4 S1 M1LA4	118	A102_21.4 P80 BN80A4	119
65	76	3.3	21.2	4590	A202_21.2 S1 M1LA4	122	A202_21.2 P80 BN80A4	123
74	66	1.5	18.6	2400	A052_18.6 S1 M1LA4	115	A052_18.6 P80 BN80A4	115
74	66	2.3	18.6	4090	A102_18.6 S1 M1LA4	118	A102_18.6 P80 BN80A4	119
84	59	1.7	16.4	2340	A052_16.4 S1 M1LA4	115	A052_16.4 P80 BN80A4	115
84	59	2.5	16.4	4710	A102_16.4 S1 M1LA4	118	A102_16.4 P80 BN80A4	119
99	50	2.0	13.9	2270	A052_13.9 S1 M1LA4	115	A052_13.9 P80 BN80A4	115
99	50	3.0	13.9	3800	A102_13.9 S1 M1LA4	118	A102_13.9 P80 BN80A4	119
112	44	2.3	12.3	2220	A052_12.3 S1 M1LA4	115	A052_12.3 P80 BN80A4	115
112	44	3.2	12.3	3670	A102_12.3 S1 M1LA4	118	A102_12.3 P80 BN80A4	119
131	38	2.6	10.6	2130	A052_10.6 S1 M1LA4	115	A052_10.6 P80 BN80A4	115
144	34	2.9	9.6	2100	A052_9.6 S1 M1LA4	115	A052_9.6 P80 BN80A4	115
162	30	3.3	8.5	2030	A052_8.5 S1 M1LA4	115	A052_8.5 P80 BN80A4	115
171	29	3.1	16.4	2000	A052_16.4 S1 M1SD2	115	A052_16.4 P71 BN71B2	115
191	26	3.9	7.2	1950	A052_7.2 S1 M1LA4	115	A052_7.2 P80 BN80A4	115
218	23	4.4	6.3	1880	A052_6.3 S1 M1LA4	115	A052_6.3 P80 BN80A4	115
229	22	4.6	12.3	1860	A052_12.3 S1 M1SD2	115	A052_12.3 P71 BN71B2	115
252	19.6	4.9	5.5	1810	A052_5.5 S1 M1LA4	115	A052_5.5 P80 BN80A4	115
267	18.5	4.3	10.6	1780	A052_10.6 S1 M1SD2	115	A052_10.6 P71 BN71B2	115
293	16.8	5.6	9.6	1740	A052_9.6 S1 M1SD2	115	A052_9.6 P71 BN71B2	115
331	14.9	6.0	8.5	1680	A052_8.5 S1 M1SD2	115	A052_8.5 P71 BN71B2	115
391	12.6	6.7	7.2	1600	A052_7.2 S1 M1SD2	115	A052_7.2 P71 BN71B2	115
445	11.1	7.2	6.3	1540	A052_6.3 S1 M1SD2	115	A052_6.3 P71 BN71B2	115
516	9.6	7.8	5.5	1480	A052_5.5 S1 M1SD2	115	A052_5.5 P71 BN71B2	115

0.75 kW

n₂ min ⁻¹	M₂ Nm	S	i	R_{n2} N				
0.56	11316	1.2	1632	75000	A904_1632 S2 M2SB6	156	A904_1632 P90 BN90S6	157
0.61	10446	1.3	1507	75000	A904_1507 S2 M2SB6	156	A904_1507 P90 BN90S6	157
0.69	9179	1.5	1324	75000	A904_1324 S2 M2SB6	156	A904_1324 P90 BN90S6	157
0.75	8473	1.7	1222	75000	A904_1222 S2 M2SB6	156	A904_1222 P90 BN90S6	157
0.86	7436	1.9	1632	75000	A904_1632 S2 M2SA4	156	A904_1632 P80 BN80B4	157
0.90	7096	1.1	1558	65000	A804_1558 S2 M2SA4	153	A804_1558 P80 BN80B4	154
0.93	6864	2.0	1507	75000	A904_1507 S2 M2SA4	156	A904_1507 P80 BN80B4	157
0.97	6550	1.2	1438	65000	A804_1438 S2 M2SA4	153	A804_1438 P80 BN80B4	154
1.0	6104	1.3	1340	65000	A804_1340 S2 M2SA4	153	A804_1340 P80 BN80B4	154
1.1	6032	2.3	1324	75000	A904_1324 S2 M2SA4	156	A904_1324 P80 BN80B4	157
1.1	5660	0.9	1242	50000	A704_1242 S2 M2SA4	150	A704_1242 P80 BN80B4	151
1.1	5635	1.4	1237	65000	A804_1237 S2 M2SA4	153	A804_1237 P80 BN80B4	154
1.1	5568	2.5	1222	75000	A904_1222 S2 M2SA4	156	A904_1222 P80 BN80B4	157
1.2	5291	0.9	1161	50000	A704_1161 S2 M2SA4	150	A704_1161 P80 BN80B4	151
1.3	5060	2.8	1111	75000	A904_1111 S2 M2SA4	156	A904_1111 P80 BN80B4	157
1.3	4942	1.6	1085	65000	A804_1085 S2 M2SA4	153	A804_1085 P80 BN80B4	154
1.3	4884	1.0	1072	50000	A704_1072 S2 M2SA4	150	A704_1072 P80 BN80B4	151
1.4	4670	3.0	1025	75000	A904_1025 S2 M2SA4	156	A904_1025 P80 BN80B4	157
1.4	4562	1.8	1001	65000	A804_1001 S2 M2SA4	153	A804_1001 P80 BN80B4	154
1.5	4270	3.3	937.2	75000	A904_937.2 S2 M2SA4	156	A904_937.2 P80 BN80B4	157
1.5	4221	1.2	926.5	50000	A704_926.5 S2 M2SA4	150	A704_926.5 P80 BN80B4	151
1.6	4094	2.0	898.7	65000	A804_898.7 S2 M2SA4	153	A804_898.7 P80 BN80B4	154
1.6	3896	1.3	855.3	50000	A704_855.3 S2 M2SA4	150	A704_855.3 P80 BN80B4	151
1.7	3779	2.1	829.5	65000	A804_829.5 S2 M2SA4	153	A804_829.5 P80 BN80B4	154
1.8	3480	1.4	763.9	50000	A704_763.9 S2 M2SA4	150	A704_763.9 P80 BN80B4	151
1.8	3472	2.3	762.1	65000	A804_762.1 S2 M2SA4	153	A804_762.1 P80 BN80B4	154
2.0	3212	1.6	705.1	50000	A704_705.1 S2 M2SA4	150	A704_705.1 P80 BN80B4	151
2.0	3205	2.5	703.5	65000	A804_703.5 S2 M2SA4	153	A804_703.5 P80 BN80B4	154





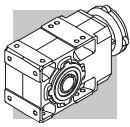

0.75 kW





n ₂ min ⁻¹	M ₂ Nm	S	i	R _{n2} N			 IEC 	
2.0	3177	0.9	697.3	30000	A604_697.3 S2 M2SA4	146	A604_697.3 P80 BN80B4	147
2.2	2937	1.7	644.6	50000	A704_644.6 S2 M2SA4	150	A704_644.6 P80 BN80B4	151
2.2	2891	1.0	634.6	30000	A604_634.6 S2 M2SA4	146	A604_634.6 P80 BN80B4	147
2.3	2766	2.9	607.2	65000	A804_607.2 S2 M2SA4	153	A804_607.2 P80 BN80B4	154
2.4	2711	1.8	595.0	50000	A704_595.0 S2 M2SA4	150	A704_595.0 P80 BN80B4	151
2.4	2669	1.0	585.8	30000	A604_585.8 S2 M2SA4	146	A604_585.8 P80 BN80B4	147
2.5	2553	3.1	560.5	65000	A804_560.5 S2 M2SA4	153	A804_560.5 P80 BN80B4	154
2.6	2469	1.1	542.0	30000	A604_542.0 S2 M2SA4	146	A604_542.0 P80 BN80B4	147
2.7	2348	2.1	515.4	50000	A704_515.4 S2 M2SA4	150	A704_515.4 P80 BN80B4	151
2.8	2279	1.2	500.3	30000	A604_500.3 S2 M2SA4	146	A604_500.3 P80 BN80B4	147
2.9	2167	2.3	475.8	50000	A704_475.8 S2 M2SA4	150	A704_475.8 P80 BN80B4	151
3.2	1997	1.4	438.4	30000	A604_438.4 S2 M2SA4	146	A604_438.4 P80 BN80B4	147
3.5	1844	1.5	404.7	30000	A604_404.7 S2 M2SA4	146	A604_404.7 P80 BN80B4	147
3.5	1823	2.7	400.2	50000	A704_400.2 S2 M2SA4	150	A704_400.2 P80 BN80B4	151
3.8	1683	3.0	369.4	50000	A704_369.4 S2 M2SA4	150	A704_369.4 P80 BN80B4	151
3.8	1666	0.9	365.6	20000	A504_365.6 S2 M2SA4	138	A504_365.6 P80 BN80B4	139
4.0	1600	1.8	351.2	30000	A604_351.2 S2 M2SA4	146	A604_351.2 P80 BN80B4	147
4.2	1515	1.0	332.6	20000	A504_332.6 S2 M2SA4	138	A504_332.6 P80 BN80B4	139
4.3	1477	1.9	324.2	30000	A604_324.2 S2 M2SA4	146	A604_324.2 P80 BN80B4	147
4.4	1441	3.5	316.4	50000	A704_316.4 S2 M2SA4	150	A704_316.4 P80 BN80B4	151
4.9	1307	1.1	286.8	20000	A504_286.8 S2 M2SA4	138	A504_286.8 P80 BN80B4	139
4.9	1304	2.1	286.3	30000	A604_286.3 S2 M2SA4	146	A604_286.3 P80 BN80B4	147
5.3	1204	2.3	264.3	30000	A604_264.3 S2 M2SA4	146	A604_264.3 P80 BN80B4	147
5.4	1189	1.3	260.9	20000	A504_260.9 S2 M2SA4	138	A504_260.9 P80 BN80B4	139
6.0	1057	1.4	232.0	20000	A504_232.0 S2 M2SA4	138	A504_232.0 P80 BN80B4	139
6.2	1030	2.7	226.1	30000	A604_226.1 S2 M2SA4	146	A604_226.1 P80 BN80B4	147
6.6	961	1.6	211.0	20000	A504_211.0 S2 M2SA4	138	A504_211.0 P80 BN80B4	139
6.7	951	2.9	208.7	30000	A604_208.7 S2 M2SA4	146	A604_208.7 P80 BN80B4	147
7.1	920	0.9	197.5	15000	A413_197.5 S2 M2SA4	134	A413_197.5 P80 BN80B4	135
7.2	905	2.2	194.2	30000	A553_194.2 S2 M2SA4	142	A553_194.2 P80 BN80B4	142
7.3	888	1.7	190.6	20000	A503_190.6 S2 M2SA4	138	A503_190.6 P80 BN80B4	139
7.5	865	3.2	185.8	30000	A603_185.8 S2 M2SA4	146	A603_185.8 P80 BN80B4	147
7.6	859	1.0	184.4	15000	A413_184.4 S2 M2SA4	134	A413_184.4 P80 BN80B4	135
8.0	815	2.5	175.0	30000	A553_175.0 S2 M2SA4	142	A553_175.0 P80 BN80B4	142
8.1	808	1.9	173.4	20000	A503_173.4 S2 M2SA4	138	A503_173.4 P80 BN80B4	139
8.2	799	3.5	171.5	30000	A603_171.5 S2 M2SA4	146	A603_171.5 P80 BN80B4	147
8.7	747	2.7	160.4	30000	A553_160.4 S2 M2SA4	142	A553_160.4 P80 BN80B4	142
9.1	720	2.1	154.6	20000	A503_154.6 S2 M2SA4	138	A503_154.6 P80 BN80B4	139
9.5	684	1.2	146.9	15000	A413_146.9 S2 M2SA4	134	A413_146.9 P80 BN80B4	135
9.5	684	2.9	146.8	30000	A553_146.8 S2 M2SA4	142	A553_146.8 P80 BN80B4	142
10.0	655	2.3	140.6	20000	A503_140.6 S2 M2SA4	138	A503_140.6 P80 BN80B4	139
10.3	635	0.9	136.3	12000	A353_136.3 S2 M2SA4	130	A353_136.3 P80 BN80B4	131
10.5	618	3.2	132.7	30000	A553_132.7 S2 M2SA4	142	A553_132.7 P80 BN80B4	142
10.8	604	2.5	129.7	20000	A503_129.7 S2 M2SA4	138	A503_129.7 P80 BN80B4	139
11.3	577	3.5	123.9	30000	A553_123.9 S2 M2SA4	142	A553_123.9 P80 BN80B4	142
11.9	549	2.7	118.0	20000	A503_118.0 S2 M2SA4	138	A503_118.0 P80 BN80B4	139
12.0	545	1.0	116.9	12000	A353_116.9 S2 M2SA4	130	A353_116.9 P80 BN80B4	131
12.1	540	1.6	115.9	15000	A413_115.9 S2 M2SA4	134	A413_115.9 P80 BN80B4	135
12.8	510	2.9	109.4	20000	A503_109.4 S2 M2SA4	138	A503_109.4 P80 BN80B4	139
13.3	492	1.1	105.5	12000	A353_105.5 S2 M2SA4	130	A353_105.5 P80 BN80B4	131
14.1	464	3.2	99.5	20000	A503_99.5 S2 M2SA4	138	A503_99.5 P80 BN80B4	139
14.6	460	1.2	95.6	12000	A352_95.6 S2 M2SA4	130	A352_95.6 P80 BN80B4	131
15.1	432	1.9	92.8	15000	A413_92.8 S2 M2SA4	134	A413_92.8 P80 BN80B4	135
17.0	397	1.5	82.5	12000	A352_82.5 S2 M2SA4	130	A352_82.5 P80 BN80B4	131
17.7	381	2.2	79.2	15000	A412_79.2 S2 M2SA4	134	A412_79.2 P80 BN80B4	135
18.3	368	1.0	76.5	8580	A302_76.5 S2 M2SA4	126	A302_76.5 P80 BN80B4	127
18.8	357	1.7	74.3	12000	A352_74.3 S2 M2SA4	130	A352_74.3 P80 BN80B4	131
19.6	343	2.5	71.3	15000	A412_71.3 S2 M2SA4	134	A412_71.3 P80 BN80B4	135
21.2	318	1.2	66.0	8360	A302_66.0 S2 M2SA4	126	A302_66.0 P80 BN80B4	127
21.3	317	1.9	65.8	12000	A352_65.8 S2 M2SA4	130	A352_65.8 P80 BN80B4	131
21.8	309	2.8	64.2	15000	A412_64.2 S2 M2SA4	134	A412_64.2 P80 BN80B4	135
23.2	290	2.1	60.4	12000	A352_60.4 S2 M2SA4	130	A352_60.4 P80 BN80B4	131
23.6	286	1.4	59.4	8190	A302_59.4 S2 M2SA4	126	A302_59.4 P80 BN80B4	127
23.8	283	3.0	58.8	15000	A412_58.8 S2 M2SA4	134	A412_58.8 P80 BN80B4	135
25.8	261	2.3	54.3	12000	A352_54.3 S2 M2SA4	130	A352_54.3 P80 BN80B4	131
26.1	258	1.0	53.7	5210	A202_53.7 S2 M2SA4	122	A202_53.7 P80 BN80B4	123



0.75 kW



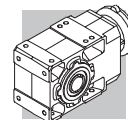

n ₂ min ⁻¹	M ₂ Nm	S	i	R _{n2} N				
26.3	256	3.3	53.1	15000	A412_53.1 S2 M2SA4	134	A412_53.1 P80 BN80B4	135
26.6	253	1.6	52.7	7990	A302_52.7 S2 M2SA4	126	A302_52.7 P80 BN80B4	127
28.5	236	2.5	49.1	12000	A352_49.1 S2 M2SA4	130	A352_49.1 P80 BN80B4	131
29.0	232	1.1	48.3	5140	A202_48.3 S2 M2SA4	122	A202_48.3 P80 BN80B4	123
29.0	232	1.8	48.3	7840	A302_48.3 S2 M2SA4	126	A302_48.3 P80 BN80B4	127
31	220	2.7	45.8	12000	A352_45.8 S2 M2SA4	130	A352_45.8 P80 BN80B4	131
32	209	2.0	43.4	7660	A302_43.4 S2 M2SA4	126	A302_43.4 P80 BN80B4	127
32	208	1.2	43.2	5060	A202_43.2 S2 M2SA4	122	A202_43.2 P80 BN80B4	123
34	201	3.0	41.8	11900	A352_41.8 S2 M2SA4	130	A352_41.8 P80 BN80B4	131
35	191	1.3	39.6	4990	A202_39.6 S2 M2SA4	122	A202_39.6 P80 BN80B4	123
36	189	2.2	39.3	7480	A302_39.3 S2 M2SA4	126	A302_39.3 P80 BN80B4	127
38	176	2.3	36.6	7360	A302_36.6 S2 M2SA4	126	A302_36.6 P80 BN80B4	127
38	176	3.4	36.6	11500	A352_36.6 S2 M2SA4	130	A352_36.6 P80 BN80B4	131
40	170	1.5	35.4	4890	A202_35.4 S2 M2SA4	122	A202_35.4 P80 BN80B4	123
40	169	0.9	35.1	4320	A102_35.1 S2 M2SA4	118	A102_35.1 P80 BN80B4	119
42	161	2.5	33.4	7200	A302_33.4 S2 M2SA4	126	A302_33.4 P80 BN80B4	127
43	155	1.0	32.2	5080	A102_32.2 S2 M2SA4	118	A102_32.2 P80 BN80B4	119
45	151	1.7	31.3	4780	A202_31.3 S2 M2SA4	122	A202_31.3 P80 BN80B4	123
48	141	2.9	29.3	6960	A302_29.3 S2 M2SA4	126	A302_29.3 P80 BN80B4	127
48	141	1.8	29.2	4710	A202_29.2 S2 M2SA4	122	A202_29.2 P80 BN80B4	123
49	137	1.1	28.6	4200	A102_28.6 S2 M2SA4	118	A102_28.6 P80 BN80B4	119
53	128	3.2	26.5	6790	A302_26.5 S2 M2SA4	126	A302_26.5 P80 BN80B4	127
53	127	2.0	26.5	4620	A202_26.5 S2 M2SA4	122	A202_26.5 P80 BN80B4	123
55	123	1.2	25.5	4900	A102_25.5 S2 M2SA4	118	A102_25.5 P80 BN80B4	119
59	114	1.3	23.8	4070	A102_23.8 S2 M2SA4	118	A102_23.8 P80 BN80B4	119
61	111	2.2	23.1	4480	A202_23.1 S2 M2SA4	122	A202_23.1 P80 BN80B4	123
66	103	1.0	21.4	2210	A052_21.4 S2 M2SA4	115	A052_21.4 P80 BN80B4	115
66	103	1.5	21.4	4740	A102_21.4 S2 M2SA4	118	A102_21.4 P80 BN80B4	119
66	102	2.4	21.2	4390	A202_21.2 S2 M2SA4	122	A202_21.2 P80 BN80B4	123
75	89	1.1	18.6	2190	A052_18.6 S2 M2SA4	115	A052_18.6 P80 BN80B4	115
75	89	1.7	18.6	3880	A102_18.6 S2 M2SA4	118	A102_18.6 P80 BN80B4	119
77	87	2.9	18.1	4230	A202_18.1 S2 M2SA4	122	A202_18.1 P80 BN80B4	123
85	79	1.3	16.4	2160	A052_16.4 S2 M2SA4	115	A052_16.4 P80 BN80B4	115
85	79	1.9	16.4	4490	A102_16.4 S2 M2SA4	118	A102_16.4 P80 BN80B4	119
87	78	3.2	16.2	4110	A202_16.2 S2 M2SA4	122	A202_16.2 P80 BN80B4	123
101	67	1.5	13.9	2110	A052_13.9 S2 M2SA4	115	A052_13.9 P80 BN80B4	115
101	67	2.2	13.9	3640	A102_13.9 S2 M2SA4	118	A102_13.9 P80 BN80B4	119
114	59	1.7	12.3	2080	A052_12.3 S2 M2SA4	115	A052_12.3 P80 BN80B4	115
114	59	2.4	12.3	3530	A102_12.3 S2 M2SA4	118	A102_12.3 P80 BN80B4	119
133	51	2.0	10.6	2010	A052_10.6 S2 M2SA4	115	A052_10.6 P80 BN80B4	115
133	51	3.0	10.6	3400	A102_10.6 S2 M2SA4	118	A102_10.6 P80 BN80B4	119
146	46	2.2	9.6	1990	A052_9.6 S2 M2SA4	115	A052_9.6 P80 BN80B4	115
146	46	3.0	9.6	3320	A102_9.6 S2 M2SA4	118	A102_9.6 P80 BN80B4	119
164	41	2.4	8.5	1940	A052_8.5 S2 M2SA4	115	A052_8.5 P80 BN80B4	115
164	41	3.4	8.5	3820	A102_8.5 S2 M2SA4	118	A102_8.5 P80 BN80B4	119
194	35	2.9	7.2	1870	A052_7.2 S2 M2SA4	115	A052_7.2 P80 BN80B4	115
221	30	3.3	6.3	1810	A052_6.3 S2 M2SA4	115	A052_6.3 P80 BN80B4	115
256	26	3.6	5.5	1750	A052_5.5 S2 M2SA4	115	A052_5.5 P80 BN80B4	115
266	25	3.2	10.6	1720	A052_10.6 S1 M1LA2	115	A052_10.6 P80 BN80A2	115
292	23	4.1	9.6	1690	A052_9.6 S1 M1LA2	115	A052_9.6 P80 BN80A2	115
330	20	4.4	8.5	1640	A052_8.5 S1 M1LA2	115	A052_8.5 P80 BN80A2	115
390	17.3	4.9	7.2	1570	A052_7.2 S1 M1LA2	115	A052_7.2 P80 BN80A2	115
444	15.2	5.3	6.3	1510	A052_6.3 S1 M1LA2	115	A052_6.3 P80 BN80A2	115
514	13.1	5.7	5.5	1450	A052_5.5 S1 M1LA2	115	A052_5.5 P80 BN80A2	115

1.1 kW

n ₂ min ⁻¹	M ₂ Nm	S	i	R _{n2} N				
0.61	15320	0.9	1507	75000	A904_1507 S3 M3SA6	156	A904_1507 P90 BN90L6	157
0.69	13462	1.0	1324	75000	A904_1324 S3 M3SA6	156	A904_1324 P90 BN90L6	157
0.75	12427	1.1	1222	75000	A904_1222 S3 M3SA6	156	A904_1222 P90 BN90L6	157
0.86	10907	1.3	1632	75000	A904_1632 S2 M2SB4	156	A904_1632 P90 BN90S4	157

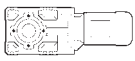



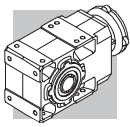

1.1 kW

n ₂ min ⁻¹	M ₂ Nm	S	i	R _{n2} N				
0.93	10068	1.4	1507	75000	A904_1507 S2 M2SB4	156	A904_1507 P90 BN90S4	157
1.0	8953	0.9	1340	65000	A804_1340 S2 M2SB4	153	A804_1340 P90 BN90S4	154
1.1	8847	1.6	1324	75000	A904_1324 S2 M2SB4	156	A904_1324 P90 BN90S4	157
1.1	8264	1.0	1237	65000	A804_1237 S2 M2SB4	153	A804_1237 P90 BN90S4	154
1.1	8166	1.7	1222	75000	A904_1222 S2 M2SB4	156	A904_1222 P90 BN90S4	157
1.3	7421	1.9	1111	75000	A904_1111 S2 M2SB4	156	A904_1111 P90 BN90S4	157
1.3	7249	1.1	1085	65000	A804_1085 S2 M2SB4	153	A804_1085 P90 BN90S4	154
1.4	6850	2.0	1025	75000	A904_1025 S2 M2SB4	156	A904_1025 P90 BN90S4	157
1.4	6691	1.2	1001	65000	A804_1001 S2 M2SB4	153	A804_1001 P90 BN90S4	154
1.5	6262	2.2	937.2	75000	A904_937.2 S2 M2SB4	156	A904_937.2 P90 BN90S4	157
1.6	6005	1.3	898.7	65000	A804_898.7 S2 M2SB4	153	A804_898.7 P90 BN90S4	154
1.6	5780	2.4	865.1	75000	A904_865.1 S2 M2SB4	156	A904_865.1 P90 BN90S4	157
1.6	5715	0.9	855.3	50000	A704_855.3 S2 M2SB4	150	A704_855.3 P90 BN90S4	151
1.7	5543	1.4	829.5	65000	A804_829.5 S2 M2SB4	153	A804_829.5 P90 BN90S4	154
1.8	5124	2.7	766.9	75000	A904_766.9 S2 M2SB4	156	A904_766.9 P90 BN90S4	157
1.8	5104	1.0	763.9	50000	A704_763.9 S2 M2SB4	150	A704_763.9 P90 BN90S4	151
1.8	5092	1.6	762.1	65000	A804_762.1 S2 M2SB4	153	A804_762.1 P90 BN90S4	154
2.0	4730	3.0	707.9	75000	A904_707.9 S2 M2SB4	156	A904_707.9 P90 BN90S4	157
2.0	4711	1.1	705.1	50000	A704_705.1 S2 M2SB4	150	A704_705.1 P90 BN90S4	151
2.0	4700	1.7	703.5	65000	A804_703.5 S2 M2SB4	153	A804_703.5 P90 BN90S4	154
2.2	4307	1.2	644.6	50000	A704_644.6 S2 M2SB4	150	A704_644.6 P90 BN90S4	151
2.3	4057	2.0	607.2	65000	A804_607.2 S2 M2SB4	153	A804_607.2 P90 BN90S4	154
2.3	4019	3.5	601.6	75000	A904_601.6 S2 M2SB4	156	A904_601.6 P90 BN90S4	157
2.4	3976	1.3	595.0	50000	A704_595.0 S2 M2SB4	150	A704_595.0 P90 BN90S4	151
2.5	3745	2.1	560.5	65000	A804_560.5 S2 M2SB4	153	A804_560.5 P90 BN90S4	154
2.7	3444	1.5	515.4	50000	A704_515.4 S2 M2SB4	150	A704_515.4 P90 BN90S4	151
2.9	3200	2.5	478.9	65000	A804_478.9 S2 M2SB4	153	A804_478.9 P90 BN90S4	154
2.9	3179	1.6	475.8	50000	A704_475.8 S2 M2SB4	150	A704_475.8 P90 BN90S4	151
3.2	2954	2.7	442.1	65000	A804_442.1 S2 M2SB4	153	A804_442.1 P90 BN90S4	154
3.2	2929	1.0	438.4	30000	A604_438.4 S2 M2SB4	146	A604_438.4 P90 BN90S4	147
3.5	2704	1.0	404.7	30000	A604_404.7 S2 M2SB4	146	A604_404.7 P90 BN90S4	147
3.5	2674	1.9	400.2	50000	A704_400.2 S2 M2SB4	150	A704_400.2 P90 BN90S4	151
3.7	2562	3.1	383.5	65000	A804_383.5 S2 M2SB4	153	A804_383.5 P90 BN90S4	154
3.8	2468	2.0	369.4	50000	A704_369.4 S2 M2SB4	150	A704_369.4 P90 BN90S4	151
4.0	2365	3.4	354.0	65000	A804_354.0 S2 M2SB4	153	A804_354.0 P90 BN90S4	154
4.0	2347	1.2	351.2	30000	A604_351.2 S2 M2SB4	146	A604_351.2 P90 BN90S4	147
4.3	2166	1.3	324.2	30000	A604_324.2 S2 M2SB4	146	A604_324.2 P90 BN90S4	147
4.4	2114	2.4	316.4	50000	A704_316.4 S2 M2SB4	150	A704_316.4 P90 BN90S4	151
4.8	1951	2.6	292.0	50000	A704_292.0 S2 M2SB4	150	A704_292.0 P90 BN90S4	151
4.9	1913	1.5	286.3	30000	A604_286.3 S2 M2SB4	146	A604_286.3 P90 BN90S4	147
5.3	1766	1.6	264.3	30000	A604_264.3 S2 M2SB4	146	A604_264.3 P90 BN90S4	147
5.4	1743	0.9	260.9	20000	A504_260.9 S2 M2SB4	138	A504_260.9 P90 BN90S4	139
5.9	1594	3.1	238.6	50000	A704_238.6 S2 M2SB4	150	A704_238.6 P90 BN90S4	151
6.0	1550	1.0	232.0	20000	A504_232.0 S2 M2SB4	138	A504_232.0 P90 BN90S4	139
6.2	1511	1.9	226.1	30000	A604_226.1 S2 M2SB4	146	A604_226.1 P90 BN90S4	147
6.4	1472	3.4	220.3	50000	A704_220.3 S2 M2SB4	150	A704_220.3 P90 BN90S4	151
6.6	1410	1.1	211.0	20000	A504_211.0 S2 M2SB4	138	A504_211.0 P90 BN90S4	139
6.7	1395	2.0	208.7	30000	A604_208.7 S2 M2SB4	146	A604_208.7 P90 BN90S4	147
7.2	1327	1.5	194.2	30000	A553_194.2 S2 M2SB4	142	A553_194.2 P90 BN90S4	142
7.3	1302	1.2	190.6	20000	A503_190.6 S2 M2SB4	138	A503_190.6 P90 BN90S4	139
7.5	1269	2.2	185.8	30000	A603_185.8 S2 M2SB4	146	A603_185.8 P90 BN90S4	147
8.0	1196	1.7	175.0	30000	A553_175.0 S2 M2SB4	142	A553_175.0 P90 BN90S4	142
8.1	1184	1.3	173.4	20000	A503_173.4 S2 M2SB4	138	A503_173.4 P90 BN90S4	139
8.2	1171	2.4	171.5	30000	A603_171.5 S2 M2SB4	146	A603_171.5 P90 BN90S4	147
8.7	1096	1.8	160.4	30000	A553_160.4 S2 M2SB4	142	A553_160.4 P90 BN90S4	142
9.0	1066	2.6	156.0	30000	A603_156.0 S2 M2SB4	146	A603_156.0 P90 BN90S4	147
9.1	1056	1.4	154.6	20000	A503_154.6 S2 M2SB4	138	A503_154.6 P90 BN90S4	139
9.5	1003	2.0	146.8	30000	A553_146.8 S2 M2SB4	142	A553_146.8 P90 BN90S4	142
9.7	984	2.8	144.0	30000	A603_144.0 S2 M2SB4	146	A603_144.0 P90 BN90S4	147
10.0	961	1.6	140.6	20000	A503_140.6 S2 M2SB4	138	A503_140.6 P90 BN90S4	139
10.5	911	3.1	133.3	30000	A603_133.3 S2 M2SB4	146	A603_133.3 P90 BN90S4	147
10.5	907	2.2	132.7	30000	A553_132.7 S2 M2SB4	142	A553_132.7 P90 BN90S4	142
10.8	886	1.7	129.7	20000	A503_129.7 S2 M2SB4	138	A503_129.7 P90 BN90S4	139
11.3	846	2.4	123.9	30000	A553_123.9 S2 M2SB4	142	A553_123.9 P90 BN90S4	142
11.4	841	3.3	123.0	30000	A603_123.0 S2 M2SB4	146	A603_123.0 P90 BN90S4	147
11.9	806	1.9	118.0	20000	A503_118.0 S2 M2SB4	138	A503_118.0 P90 BN90S4	139





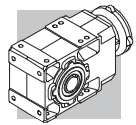

1.1 kW





n ₂ min ⁻¹	M ₂ Nm	S	i	R _{n2} N				
12.1	792	1.1	115.9	15000	A413_115.9 S2 M2SB4	134	A413_115.9 P90 BN90S4	135
12.8	748	2.0	109.4	20000	A503_109.4 S2 M2SB4	138	A503_109.4 P90 BN90S4	139
13.8	693	2.9	101.4	30000	A553_101.4 S2 M2SB4	142	A553_101.4 P90 BN90S4	142
14.1	680	2.2	99.5	20000	A503_99.5 S2 M2SB4	138	A503_99.5 P90 BN90S4	139
15.1	634	1.3	92.8	15000	A413_92.8 S2 M2SB4	134	A413_92.8 P90 BN90S4	135
15.6	612	2.5	89.5	20000	A503_89.5 S2 M2SB4	138	A503_89.5 P90 BN90S4	139
17.0	582	1.0	82.5	12000	A352_82.5 S2 M2SB4	130	A352_82.5 P90 BN90S4	131
17.2	556	2.7	81.5	20000	A503_81.5 S2 M2SB4	138	A503_81.5 P90 BN90S4	139
17.7	559	1.5	79.2	15000	A412_79.2 S2 M2SB4	134	A412_79.2 P90 BN90S4	135
18.8	524	1.1	74.3	12000	A352_74.3 S2 M2SB4	130	A352_74.3 P90 BN90S4	131
19.6	503	1.7	71.3	15000	A412_71.3 S2 M2SB4	134	A412_71.3 P90 BN90S4	135
19.9	480	3.1	70.2	20000	A503_70.2 S2 M2SB4	138	A503_70.2 P90 BN90S4	139
21.3	465	1.3	65.8	12000	A352_65.8 S2 M2SB4	130	A352_65.8 P90 BN90S4	131
21.8	453	1.9	64.2	15000	A412_64.2 S2 M2SB4	134	A412_64.2 P90 BN90S4	135
21.9	436	3.4	63.9	20000	A503_63.9 S2 M2SB4	138	A503_63.9 P90 BN90S4	139
23.2	426	1.4	60.4	12000	A352_60.4 S2 M2SB4	130	A352_60.4 P90 BN90S4	131
23.6	419	1.0	59.4	7420	A302_59.4 S2 M2SB4	126	A302_59.4 P90 BN90S4	127
23.8	415	2.0	58.8	15000	A412_58.8 S2 M2SB4	134	A412_58.8 P90 BN90S4	135
25.8	383	1.6	54.3	12000	A352_54.3 S2 M2SB4	130	A352_54.3 P90 BN90S4	131
26.3	375	2.3	53.1	15000	A412_53.1 S2 M2SB4	134	A412_53.1 P90 BN90S4	135
26.6	372	1.1	52.7	7310	A302_52.7 S2 M2SB4	126	A302_52.7 P90 BN90S4	127
28.5	346	1.7	49.1	11800	A352_49.1 S2 M2SB4	130	A352_49.1 P90 BN90S4	131
29.0	341	1.2	48.3	7220	A302_48.3 S2 M2SB4	126	A302_48.3 P90 BN90S4	127
29.0	341	2.5	48.3	15000	A412_48.3 S2 M2SB4	134	A412_48.3 P90 BN90S4	135
31	323	1.9	45.8	11700	A352_45.8 S2 M2SB4	130	A352_45.8 P90 BN90S4	131
31	318	2.6	45.1	15000	A412_45.1 S2 M2SB4	134	A412_45.1 P90 BN90S4	135
32	306	1.3	43.4	7100	A302_43.4 S2 M2SB4	126	A302_43.4 P90 BN90S4	127
34	295	2.0	41.8	11400	A352_41.8 S2 M2SB4	130	A352_41.8 P90 BN90S4	131
36	277	1.5	39.3	6970	A302_39.3 S2 M2SB4	126	A302_39.3 P90 BN90S4	127
38	259	1.6	36.6	6880	A302_36.6 S2 M2SB4	126	A302_36.6 P90 BN90S4	127
38	258	2.3	36.6	11100	A352_36.6 S2 M2SB4	130	A352_36.6 P90 BN90S4	131
39	253	3.1	35.9	14300	A412_35.9 S2 M2SB4	134	A412_35.9 P90 BN90S4	135
40	250	1.0	35.4	4380	A202_35.4 S2 M2SB4	122	A202_35.4 P90 BN90S4	123
42	236	1.7	33.4	6760	A302_33.4 S2 M2SB4	126	A302_33.4 P90 BN90S4	127
42	234	2.6	33.2	10800	A352_33.2 S2 M2SB4	130	A352_33.2 P90 BN90S4	131
45	221	1.1	31.3	4320	A202_31.3 S2 M2SB4	122	A202_31.3 P90 BN90S4	123
48	207	2.0	29.3	6580	A302_29.3 S2 M2SB4	126	A302_29.3 P90 BN90S4	127
48	206	1.2	29.2	4290	A202_29.2 S2 M2SB4	122	A202_29.2 P90 BN90S4	123
49	201	3.0	28.4	10400	A352_28.4 S2 M2SB4	130	A352_28.4 P90 BN90S4	131
53	187	2.2	26.5	6440	A302_26.5 S2 M2SB4	126	A302_26.5 P90 BN90S4	127
53	187	1.3	26.5	4230	A202_26.5 S2 M2SB4	122	A202_26.5 P90 BN90S4	123
55	181	3.3	25.7	10100	A352_25.7 S2 M2SB4	130	A352_25.7 P90 BN90S4	131
59	168	0.9	23.8	3640	A102_23.8 S2 M2SB4	118	A102_23.8 P90 BN90S4	119
61	163	1.5	23.1	4140	A202_23.1 S2 M2SB4	122	A202_23.1 P90 BN90S4	123
62	161	2.6	22.8	6220	A302_22.8 S2 M2SB4	126	A302_22.8 P90 BN90S4	127
66	151	1.0	21.4	4280	A102_21.4 S2 M2SB4	118	A102_21.4 P90 BN90S4	119
66	150	1.7	21.2	4080	A202_21.2 S2 M2SB4	122	A202_21.2 P90 BN90S4	123
68	145	2.8	20.5	6070	A302_20.5 S2 M2SB4	126	A302_20.5 P90 BN90S4	127
75	131	1.1	18.6	3540	A102_18.6 S2 M2SB4	118	A102_18.6 P90 BN90S4	119
77	128	2.0	18.1	3970	A202_18.1 S2 M2SB4	122	A202_18.1 P90 BN90S4	123
78	127	3.2	18.0	5880	A302_18.0 S2 M2SB4	126	A302_18.0 P90 BN90S4	127
85	116	1.3	16.4	4130	A102_16.4 S2 M2SB4	118	A102_16.4 P90 BN90S4	119
86	115	3.3	16.3	5740	A302_16.3 S2 M2SB4	126	A302_16.3 P90 BN90S4	127
87	114	2.2	16.2	3880	A202_16.2 S2 M2SB4	122	A202_16.2 P90 BN90S4	123
99	99	2.5	14.1	3770	A202_14.1 S2 M2SB4	122	A202_14.1 P90 BN90S4	123
101	98	1.0	13.9	1840	A052_13.9 S2 M2SB4	115		
101	98	1.5	13.9	3380	A102_13.9 S2 M2SB4	118	A102_13.9 P90 BN90S4	119
114	87	1.2	12.3	1850	A052_12.3 S2 M2SB4	115		
114	87	1.6	12.3	3300	A102_12.3 S2 M2SB4	118	A102_12.3 P90 BN90S4	119
117	84	2.5	12.0	3620	A202_12.0 S2 M2SB4	122	A202_12.0 P90 BN90S4	123
133	75	1.3	10.6	1810	A052_10.6 S2 M2SB4	115		
133	75	2.0	10.6	3210	A102_10.6 S2 M2SB4	118	A102_10.6 P90 BN90S4	119
135	73	3.1	10.3	3510	A202_10.3 S2 M2SB4	122	A202_10.3 P90 BN90S4	123
146	68	1.5	9.6	1810	A052_9.6 S2 M2SB4	115		
146	68	2.1	9.6	3140	A102_9.6 S2 M2SB4	118	A102_9.6 P90 BN90S4	119
149	66	3.2	9.4	3420	A202_9.4 S2 M2SB4	122	A202_9.4 P90 BN90S4	123



1.1 kW



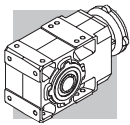

n ₂ min ⁻¹	M ₂ Nm	S	i	R _{n2} N				
164	60	1.7	8.5	1780	A052_8.5 S2 M2SB4	115		
164	60	2.3	8.5	3630	A102_8.5 S2 M2SB4	118	A102_8.5 P90 BN90S4	119
194	51	2.0	7.2	1730	A052_7.2 S2 M2SB4	115		
194	51	2.8	7.2	2940	A102_7.2 S2 M2SB4	118	A102_7.2 P90 BN90S4	119
221	45	2.2	6.3	1690	A052_6.3 S2 M2SB4	115		
221	45	3.1	6.3	3390	A102_6.3 S2 M2SB4	118	A102_6.3 P90 BN90S4	119
228	43	3.2	12.3	2830	A102_12.3 S2 M2SA2	118	A102_12.3 P80 BN80B2	119
256	39	2.5	5.5	1640	A052_5.5 S2 M2SB4	115		
291	34	2.8	9.6	1600	A052_9.6 S2 M2SA2	115	A052_9.6 P80 BN80B2	115
329	30	3.0	8.5	1560	A052_8.5 S2 M2SA2	115	A052_8.5 P80 BN80B2	115
388	25	3.3	7.2	1500	A052_7.2 S2 M2SA2	115	A052_7.2 P80 BN80B2	115
442	22	3.6	6.3	1450	A052_6.3 S2 M2SA2	115	A052_6.3 P80 BN80B2	115
512	19.3	3.9	5.5	1400	A052_5.5 S2 M2SA2	115	A052_5.5 P80 BN80B2	115

1.5 kW

n ₂ min ⁻¹	M ₂ Nm	S	i	R _{n2} N				
0.86	14767	0.9	1632	75000	A904_1632 S3 M3SA4	156	A904_1632 P90 BN90LA4	157
0.94	13631	1.0	1507	75000	A904_1507 S3 M3SA4	156	A904_1507 P90 BN90LA4	157
1.1	11978	1.2	1324	75000	A904_1324 S3 M3SA4	156	A904_1324 P90 BN90LA4	157
1.2	11057	1.3	1222	75000	A904_1222 S3 M3SA4	156	A904_1222 P90 BN90LA4	157
1.3	10047	1.4	1111	75000	A904_1111 S3 M3SA4	156	A904_1111 P90 BN90LA4	157
1.4	9274	1.5	1025	75000	A904_1025 S3 M3SA4	156	A904_1025 P90 BN90LA4	157
1.4	9060	0.9	1001	65000	A804_1001 S3 M3SA4	153	A804_1001 P90 BN90LA4	154
1.5	8478	1.7	937.2	75000	A904_937.2 S3 M3SA4	156	A904_937.2 P90 BN90LA4	157
1.6	8130	1.0	898.7	65000	A804_898.7 S3 M3SA4	153	A804_898.7 P90 BN90LA4	154
1.6	7826	1.8	865.1	75000	A904_865.1 S3 M3SA4	156	A904_865.1 P90 BN90LA4	157
1.7	7505	1.1	829.5	65000	A804_829.5 S3 M3SA4	153	A804_829.5 P90 BN90LA4	154
1.8	6938	2.0	766.9	75000	A904_766.9 S3 M3SA4	156	A904_766.9 P90 BN90LA4	157
1.9	6894	1.2	762.1	65000	A804_762.1 S3 M3SA4	153	A804_762.1 P90 BN90LA4	154
2.0	6404	2.2	707.9	75000	A904_707.9 S3 M3SA4	156	A904_707.9 P90 BN90LA4	157
2.0	6364	1.3	703.5	65000	A804_703.5 S3 M3SA4	153	A804_703.5 P90 BN90LA4	154
2.2	5832	0.9	644.6	50000	A704_644.6 S3 M3SA4	150	A704_644.6 P90 BN90LA4	151
2.3	5493	1.5	607.2	65000	A804_607.2 S3 M3SA4	153	A804_607.2 P90 BN90LA4	154
2.3	5442	2.6	601.6	75000	A904_601.6 S3 M3SA4	156	A904_601.6 P90 BN90LA4	157
2.4	5383	0.9	595.0	50000	A704_595.0 S3 M3SA4	150	A704_595.0 P90 BN90LA4	151
2.5	5070	1.6	560.5	65000	A804_560.5 S3 M3SA4	153	A804_560.5 P90 BN90LA4	154
2.5	5024	2.8	555.3	75000	A904_555.3 S3 M3SA4	156	A904_555.3 P90 BN90LA4	157
2.7	4663	1.1	515.4	50000	A704_515.4 S3 M3SA4	150	A704_515.4 P90 BN90LA4	151
2.9	4402	3.2	486.6	75000	A904_486.6 S3 M3SA4	156	A904_486.6 P90 BN90LA4	157
2.9	4333	1.8	478.9	65000	A804_478.9 S3 M3SA4	153	A804_478.9 P90 BN90LA4	154
3.0	4304	1.2	475.8	50000	A704_475.8 S3 M3SA4	150	A704_475.8 P90 BN90LA4	151
3.1	4063	3.4	449.2	75000	A904_449.2 S3 M3SA4	156	A904_449.2 P90 BN90LA4	157
3.2	3999	2.0	442.1	65000	A804_442.1 S3 M3SA4	153	A804_442.1 P90 BN90LA4	154
3.5	3620	1.4	400.2	50000	A704_400.2 S3 M3SA4	150	A704_400.2 P90 BN90LA4	151
3.7	3469	2.3	383.5	65000	A804_383.5 S3 M3SA4	153	A804_383.5 P90 BN90LA4	154
3.8	3342	1.5	369.4	50000	A704_369.4 S3 M3SA4	150	A704_369.4 P90 BN90LA4	151
4.0	3202	2.5	354.0	65000	A804_354.0 S3 M3SA4	153	A804_354.0 P90 BN90LA4	154
4.0	3177	0.9	351.2	30000	A604_351.2 S3 M3SA4	146	A604_351.2 P90 BN90LA4	147
4.3	2933	1.0	324.2	30000	A604_324.2 S3 M3SA4	146	A604_324.2 P90 BN90LA4	147
4.5	2862	1.7	316.4	50000	A704_316.4 S3 M3SA4	150	A704_316.4 P90 BN90LA4	151
4.7	2718	2.9	300.4	65000	A804_300.4 S3 M3SA4	153	A804_300.4 P90 BN90LA4	154
4.8	2642	1.9	292.0	50000	A704_292.0 S3 M3SA4	150	A704_292.0 P90 BN90LA4	151
4.9	2590	1.1	286.3	30000	A604_286.3 S3 M3SA4	146	A604_286.3 P90 BN90LA4	147
5.1	2509	3.2	277.3	65000	A804_277.3 S3 M3SA4	153	A804_277.3 P90 BN90LA4	154
5.3	2391	1.2	264.3	30000	A604_264.3 S3 M3SA4	146	A604_264.3 P90 BN90LA4	147
5.9	2159	2.3	238.6	50000	A704_238.6 S3 M3SA4	150	A704_238.6 P90 BN90LA4	151
6.2	2046	1.4	226.1	30000	A604_226.1 S3 M3SA4	146	A604_226.1 P90 BN90LA4	147
6.4	1993	2.5	220.3	50000	A704_220.3 S3 M3SA4	150	A704_220.3 P90 BN90LA4	151
6.8	1888	1.5	208.7	30000	A604_208.7 S3 M3SA4	146	A604_208.7 P90 BN90LA4	147
7.3	1796	1.1	194.2	30000	A553_194.2 S3 M3SA4	142	A553_194.2 P90 BN90LA4	142
7.6	1718	1.6	185.8	30000	A603_185.8 S3 M3SA4	146	A603_185.8 P90 BN90LA4	147

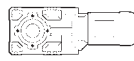



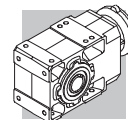

1.5 kW





n ₂ min ⁻¹	M ₂ Nm	S	i	R _{n2} N				
7.7	1664	3.0	183.9	50000	A704_183.9 S3 M3SA4	150	A704_183.9 P90 BN90LA4	151
8.1	1619	1.2	175.0	30000	A553_175.0 S3 M3SA4	142	A553_175.0 P90 BN90LA4	142
8.1	1604	0.9	173.4	20000	A503_173.4 S3 M3SA4	138	A503_173.4 P90 BN90LA4	139
8.2	1586	1.8	171.5	30000	A603_171.5 S3 M3SA4	146	A603_171.5 P90 BN90LA4	147
8.3	1536	3.3	169.8	50000	A704_169.8 S3 M3SA4	150	A704_169.8 P90 BN90LA4	151
8.8	1484	1.3	160.4	30000	A553_160.4 S3 M3SA4	142	A553_160.4 P90 BN90LA4	142
9.0	1443	1.9	156.0	30000	A603_156.0 S3 M3SA4	146	A603_156.0 P90 BN90LA4	147
9.1	1430	1.0	154.6	20000	A503_154.6 S3 M3SA4	138	A503_154.6 P90 BN90LA4	139
9.2	1422	2.8	153.7	50000	A703_153.7 S3 M3SA4	150	A703_153.7 P90 BN90LA4	151
9.6	1358	1.5	146.8	30000	A553_146.8 S3 M3SA4	142	A553_146.8 P90 BN90LA4	142
9.8	1332	2.1	144.0	30000	A603_144.0 S3 M3SA4	146	A603_144.0 P90 BN90LA4	147
10.0	1301	1.2	140.6	20000	A503_140.6 S3 M3SA4	138	A503_140.6 P90 BN90LA4	139
10.6	1233	2.3	133.3	30000	A603_133.3 S3 M3SA4	146	A603_133.3 P90 BN90LA4	147
10.6	1228	1.6	132.7	30000	A553_132.7 S3 M3SA4	142	A553_132.7 P90 BN90LA4	142
10.9	1199	1.3	129.7	20000	A503_129.7 S3 M3SA4	138	A503_129.7 P90 BN90LA4	139
11.4	1146	1.7	123.9	30000	A553_123.9 S3 M3SA4	142	A553_123.9 P90 BN90LA4	142
11.5	1138	2.5	123.0	30000	A603_123.0 S3 M3SA4	146	A603_123.0 P90 BN90LA4	147
12.0	1091	1.4	118.0	20000	A503_118.0 S3 M3SA4	138	A503_118.0 P90 BN90LA4	139
12.9	1012	1.5	109.4	20000	A503_109.4 S3 M3SA4	138	A503_109.4 P90 BN90LA4	139
13.1	997	2.8	107.8	30000	A603_107.8 S3 M3SA4	146	A603_107.8 P90 BN90LA4	147
13.9	938	2.1	101.4	30000	A553_101.4 S3 M3SA4	142	A553_101.4 P90 BN90LA4	142
14.2	921	1.6	99.5	20000	A503_99.5 S3 M3SA4	138	A503_99.5 P90 BN90LA4	139
14.2	920	3.0	99.5	30000	A603_99.5 S3 M3SA4	146	A603_99.5 P90 BN90LA4	147
15.2	858	0.9	92.8	15000	A413_92.8 S3 M3SA4	134	A413_92.8 P90 BN90LA4	135
15.7	828	1.8	89.5	20000	A503_89.5 S3 M3SA4	138	A503_89.5 P90 BN90LA4	139
16.3	799	3.5	86.4	30000	A603_86.4 S3 M3SA4	146	A603_86.4 P90 BN90LA4	147
17.3	753	2.0	81.5	20000	A503_81.5 S3 M3SA4	138	A503_81.5 P90 BN90LA4	139
17.7	736	2.7	79.5	30000	A553_79.5 S3 M3SA4	142	A553_79.5 P90 BN90LA4	142
17.8	757	1.1	79.2	15000	A412_79.2 S3 M3SA4	134	A412_79.2 P90 BN90LA4	135
19.8	681	1.2	71.3	15000	A412_71.3 S3 M3SA4	134	A412_71.3 P90 BN90LA4	135
20.1	650	2.3	70.2	20000	A503_70.2 S3 M3SA4	138	A503_70.2 P90 BN90LA4	139
21.4	629	1.0	65.8	11600	A352_65.8 S3 M3SA4	130	A352_65.8 P90 BN90LA4	131
21.9	595	3.4	64.3	30000	A553_64.3 S3 M3SA4	142	A553_64.3 P90 BN90LA4	142
22.0	613	1.4	64.2	15000	A412_64.2 S3 M3SA4	134	A412_64.2 P90 BN90LA4	135
22.1	591	2.5	63.9	20000	A503_63.9 S3 M3SA4	138	A503_63.9 P90 BN90LA4	139
23.4	577	1.0	60.4	11500	A352_60.4 S3 M3SA4	130	A352_60.4 P90 BN90LA4	131
24.0	562	1.5	58.8	15000	A412_58.8 S3 M3SA4	134	A412_58.8 P90 BN90LA4	135
24.8	526	2.9	56.8	20000	A503_56.8 S3 M3SA4	138	A503_56.8 P90 BN90LA4	139
26.0	519	1.2	54.3	11300	A352_54.3 S3 M3SA4	130	A352_54.3 P90 BN90LA4	131
26.5	508	1.7	53.1	15000	A412_53.1 S3 M3SA4	134	A412_53.1 P90 BN90LA4	135
27.3	478	3.1	51.7	19700	A503_51.7 S3 M3SA4	138	A503_51.7 P90 BN90LA4	139
28.7	469	1.3	49.1	11100	A352_49.1 S3 M3SA4	130	A352_49.1 P90 BN90LA4	131
29.2	461	1.8	48.3	14900	A412_48.3 S3 M3SA4	134	A412_48.3 P90 BN90LA4	135
31	438	1.4	45.8	11000	A352_45.8 S3 M3SA4	130	A352_45.8 P90 BN90LA4	131
31	431	1.9	45.1	14600	A412_45.1 S3 M3SA4	134	A412_45.1 P90 BN90LA4	135
32	415	1.0	43.4	6450	A302_43.4 S3 M3SA4	126	A302_43.4 P90 BN90LA4	127
34	399	1.5	41.8	10800	A352_41.8 S3 M3SA4	130	A352_41.8 P90 BN90LA4	131
36	375	1.1	39.3	6380	A302_39.3 S3 M3SA4	126	A302_39.3 P90 BN90LA4	127
38	350	1.2	36.6	6330	A302_36.6 S3 M3SA4	126	A302_36.6 P90 BN90LA4	127
38	350	1.7	36.6	10500	A352_36.6 S3 M3SA4	130	A352_36.6 P90 BN90LA4	131
39	343	2.3	35.9	13800	A412_35.9 S3 M3SA4	134	A412_35.9 P90 BN90LA4	135
42	319	1.3	33.4	6260	A302_33.4 S3 M3SA4	126	A302_33.4 P90 BN90LA4	127
43	317	1.9	33.2	10300	A352_33.2 S3 M3SA4	130	A352_33.2 P90 BN90LA4	131
48	280	1.5	29.3	6140	A302_29.3 S3 M3SA4	126	A302_29.3 P90 BN90LA4	127
50	272	2.2	28.4	9940	A352_28.4 S3 M3SA4	130	A352_28.4 P90 BN90LA4	131
50	271	2.7	28.3	13000	A412_28.3 S3 M3SA4	134	A412_28.3 P90 BN90LA4	135
53	254	1.6	26.5	6040	A302_26.5 S3 M3SA4	126	A302_26.5 P90 BN90LA4	127
53	253	1.0	26.5	3790	A202_26.5 S3 M3SA4	122	A202_26.5 P90 BN90LA4	123
55	245	2.4	25.7	9710	A352_25.7 S3 M3SA4	130	A352_25.7 P90 BN90LA4	131
61	221	1.1	23.1	3760	A202_23.1 S3 M3SA4	122	A202_23.1 P90 BN90LA4	123
62	217	1.9	22.8	5870	A302_22.8 S3 M3SA4	126	A302_22.8 P90 BN90LA4	127
62	217	3.1	22.7	12200	A412_22.7 S3 M3SA4	134	A412_22.7 P90 BN90LA4	135
63	215	2.8	22.5	9400	A352_22.5 S3 M3SA4	130	A352_22.5 P90 BN90LA4	131
66	203	1.2	21.2	3730	A202_21.2 S3 M3SA4	122	A202_21.2 P90 BN90LA4	123
69	196	2.1	20.5	5760	A302_20.5 S3 M3SA4	126	A302_20.5 P90 BN90LA4	127
69	195	3.1	20.4	9170	A352_20.4 S3 M3SA4	130	A352_20.4 P90 BN90LA4	131



1.5 kW



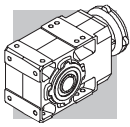

n₂ min ⁻¹	M₂ Nm	S	i	R_{n2} N			 IEC 	
78	173	1.4	18.1	3660	A202_18.1 S3 M3SA4	122	A202_18.1 P90 BN90LA4	123
78	172	2.3	18.0	5600	A302_18.0 S3 M3SA4	126	A302_18.0 P90 BN90LA4	127
86	157	1.0	16.4	3720	A102_16.4 S3 M3SA4	118	A102_16.4 P90 BN90LA4	119
86	156	2.5	16.3	5480	A302_16.3 S3 M3SA4	126	A302_16.3 P90 BN90LA4	127
87	154	1.6	16.2	3600	A202_16.2 S3 M3SA4	122	A202_16.2 P90 BN90LA4	123
100	134	1.8	14.1	3530	A202_14.1 S3 M3SA4	122	A202_14.1 P90 BN90LA4	123
101	133	1.1	13.9	3090	A102_13.9 S3 M3SA4	118	A102_13.9 P90 BN90LA4	119
104	130	2.9	13.6	5250	A302_13.6 S3 M3SA4	126	A302_13.6 P90 BN90LA4	127
115	118	1.2	12.3	3040	A102_12.3 S3 M3SA4	118	A102_12.3 P90 BN90LA4	119
118	114	1.8	12.0	3420	A202_12.0 S3 M3SA4	122	A202_12.0 P90 BN90LA4	123
120	113	2.7	11.8	5060	A302_11.8 S3 M3SA4	126	A302_11.8 P90 BN90LA4	127
123	109	3.2	22.8	5040	A302_22.8 S2 M2SB2	126	A302_22.8 P90 BN90SA2	127
134	101	1.5	10.6	2990	A102_10.6 S3 M3SA4	118	A102_10.6 P90 BN90LA4	119
135	100	3.4	10.5	4930	A302_10.5 S3 M3SA4	126	A302_10.5 P90 BN90LA4	127
136	99	2.3	10.3	3330	A202_10.3 S3 M3SA4	122	A202_10.3 P90 BN90LA4	123
147	92	1.5	9.6	2940	A102_9.6 S3 M3SA4	118	A102_9.6 P90 BN90LA4	119
150	90	2.3	9.4	3250	A202_9.4 S3 M3SA4	122	A202_9.4 P90 BN90LA4	123
151	89	3.4	9.3	4770	A302_9.3 S3 M3SA4	126	A302_9.3 P90 BN90LA4	127
166	81	1.7	8.5	3420	A102_8.5 S3 M3SA4	118	A102_8.5 P90 BN90LA4	119
168	80	2.6	8.4	3180	A202_8.4 S3 M3SA4	122	A202_8.4 P90 BN90LA4	123
193	70	3.0	7.3	3080	A202_7.3 S3 M3SA4	122	A202_7.3 P90 BN90LA4	123
196	69	2.0	7.2	2790	A102_7.2 S3 M3SA4	118	A102_7.2 P90 BN90LA4	119
216	62	3.4	6.5	3000	A202_6.5 S3 M3SA4	122	A202_6.5 P90 BN90LA4	123
223	61	2.3	6.3	3220	A102_6.3 S3 M3SA4	118	A102_6.3 P90 BN90LA4	119
258	52	2.7	5.5	2630	A102_5.5 S3 M3SA4	118	A102_5.5 P90 BN90LA4	119
291	46	3.0	9.6	2560	A102_9.6 S2 M2SB2	118	A102_9.6 P90 BN90SA2	119
329	41	3.4	8.5	2950	A102_8.5 S2 M2SB2	118	A102_8.5 P90 BN90SA2	119
388	35	2.4	7.2	1420	A052_7.2 S2 M2SB2	115		
442	30	2.6	6.3	1380	A052_6.3 S2 M2SB2	115		
512	26	2.9	5.5	1340	A052_5.5 S2 M2SB2	115		

2.2 kW

n₂ min ⁻¹	M₂ Nm	S	i	R_{n2} N			 IEC 	
1.2	16217	0.9	1222	75000	A904_1222 S3 M3LA4	156	A904_1222 P100 BN100LA4	157
1.3	14736	1.0	1111	75000	A904_1111 S3 M3LA4	156	A904_1111 P100 BN100LA4	157
1.4	13602	1.0	1025	75000	A904_1025 S3 M3LA4	156	A904_1025 P100 BN100LA4	157
1.5	12435	1.1	937.2	75000	A904_937.2 S3 M3LA4	156	A904_937.2 P100 BN100LA4	157
1.6	11479	1.2	865.1	75000	A904_865.1 S3 M3LA4	156	A904_865.1 P100 BN100LA4	157
1.8	10176	1.4	766.9	75000	A904_766.9 S3 M3LA4	156	A904_766.9 P100 BN100LA4	157
2.0	9393	1.5	707.9	75000	A904_707.9 S3 M3LA4	156	A904_707.9 P100 BN100LA4	157
2.0	9334	0.9	703.5	65000	A804_703.5 S3 M3LA4	153	A804_703.5 P100 BN100LA4	154
2.3	8056	1.0	607.2	65000	A804_607.2 S3 M3LA4	153	A804_607.2 P100 BN100LA4	154
2.3	7982	1.8	601.6	75000	A904_601.6 S3 M3LA4	156	A904_601.6 P100 BN100LA4	157
2.5	7436	1.1	560.5	65000	A804_560.5 S3 M3LA4	153	A804_560.5 P100 BN100LA4	154
2.5	7368	1.9	555.3	75000	A904_555.3 S3 M3LA4	156	A904_555.3 P100 BN100LA4	157
2.9	6456	2.2	486.6	75000	A904_486.6 S3 M3LA4	156	A904_486.6 P100 BN100LA4	157
2.9	6355	1.3	478.9	65000	A804_478.9 S3 M3LA4	153	A804_478.9 P100 BN100LA4	154
3.1	5960	2.3	449.2	75000	A904_449.2 S3 M3LA4	156	A904_449.2 P100 BN100LA4	157
3.2	5866	1.4	442.1	65000	A804_442.1 S3 M3LA4	153	A804_442.1 P100 BN100LA4	154
3.5	5310	0.9	400.2	50000	A704_400.2 S3 M3LA4	150	A704_400.2 P100 BN100LA4	151
3.7	5114	2.7	385.4	75000	A904_385.4 S3 M3LA4	156	A904_385.4 P100 BN100LA4	157
3.7	5088	1.6	383.5	65000	A804_383.5 S3 M3LA4	153	A804_383.5 P100 BN100LA4	154
3.8	4901	1.0	369.4	50000	A704_369.4 S3 M3LA4	150	A704_369.4 P100 BN100LA4	151
4.0	4721	3.0	355.8	75000	A904_355.8 S3 M3LA4	156	A904_355.8 P100 BN100LA4	157
4.0	4697	1.7	354.0	65000	A804_354.0 S3 M3LA4	153	A804_354.0 P100 BN100LA4	154
4.5	4198	1.2	316.4	50000	A704_316.4 S3 M3LA4	150	A704_316.4 P100 BN100LA4	151
4.6	4045	3.5	304.9	75000	A904_304.9 S3 M3LA4	156	A904_304.9 P100 BN100LA4	157
4.7	3986	2.0	300.4	65000	A804_300.4 S3 M3LA4	153	A804_300.4 P100 BN100LA4	154
4.8	3875	1.3	292.0	50000	A704_292.0 S3 M3LA4	150	A704_292.0 P100 BN100LA4	151
5.1	3679	2.2	277.3	65000	A804_277.3 S3 M3LA4	153	A804_277.3 P100 BN100LA4	154
5.9	3166	1.6	238.6	50000	A704_238.6 S3 M3LA4	150	A704_238.6 P100 BN100LA4	151





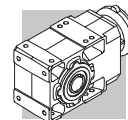

2.2 kW



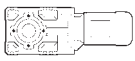

n ₂ min-1	M ₂ Nm	S	i	R _{n2} N				
6.1	3087	2.6	232.6	65000	A804_232.6 S3 M3LA4	153	A804_232.6 P100 BN100LA4	154
6.2	3000	0.9	226.1	30000	A604_226.1 S3 M3LA4	146	A604_226.1 P100 BN100LA4	147
6.4	2922	1.7	220.3	50000	A704_220.3 S3 M3LA4	150	A704_220.3 P100 BN100LA4	151
6.6	2849	2.8	214.7	65000	A804_214.7 S3 M3LA4	153	A804_214.7 P100 BN100LA4	154
6.8	2770	1.0	208.7	30000	A604_208.7 S3 M3LA4	146	A604_208.7 P100 BN100LA4	147
7.6	2520	1.1	185.8	30000	A603_185.8 S3 M3LA4	146	A603_185.8 P100 BN100LA4	147
7.7	2440	2.0	183.9	50000	A704_183.9 S3 M3LA4	150	A704_183.9 P100 BN100LA4	151
8.2	2326	1.2	171.5	30000	A603_171.5 S3 M3LA4	146	A603_171.5 P100 BN100LA4	147
8.2	2273	3.5	171.3	65000	A804_171.3 S3 M3LA4	153	A804_171.3 P100 BN100LA4	154
8.3	2252	2.2	169.8	50000	A704_169.8 S3 M3LA4	150	A704_169.8 P100 BN100LA4	151
8.8	2177	0.9	160.4	30000	A553_160.4 S3 M3LA4	142	A553_160.4 P100 BN100LA4	142
9.0	2117	1.3	156.0	30000	A603_156.0 S3 M3LA4	146	A603_156.0 P100 BN100LA4	147
9.2	2085	1.9	153.7	50000	A703_153.7 S3 M3LA4	150	A703_153.7 P100 BN100LA4	151
9.6	1992	1.0	146.8	30000	A553_146.8 S3 M3LA4	142	A553_146.8 P100 BN100LA4	142
9.8	1954	1.4	144.0	30000	A603_144.0 S3 M3LA4	146	A603_144.0 P100 BN100LA4	147
9.9	1925	2.6	141.9	50000	A703_141.9 S3 M3LA4	150	A703_141.9 P100 BN100LA4	151
10.6	1808	1.5	133.3	30000	A603_133.3 S3 M3LA4	146	A603_133.3 P100 BN100LA4	147
10.6	1801	1.1	132.7	30000	A553_132.7 S3 M3LA4	142	A553_132.7 P100 BN100LA4	142
10.8	1773	2.8	130.7	50000	A703_130.7 S3 M3LA4	150	A703_130.7 P100 BN100LA4	151
11.4	1681	1.2	123.9	30000	A553_123.9 S3 M3LA4	142	A553_123.9 P100 BN100LA4	142
11.5	1669	1.7	123.0	30000	A603_123.0 S3 M3LA4	146	A603_123.0 P100 BN100LA4	147
11.7	1636	3.1	120.6	50000	A703_120.6 S3 M3LA4	150	A703_120.6 P100 BN100LA4	151
12.0	1600	0.9	118.0	20000	A503_118.0 S3 M3LA4	138	A503_118.0 P100 BN100LA4	139
12.9	1485	1.0	109.4	20000	A503_109.4 S3 M3LA4	138	A503_109.4 P100 BN100LA4	139
13.1	1463	1.9	107.8	30000	A603_107.8 S3 M3LA4	146	A603_107.8 P100 BN100LA4	147
13.5	1414	3.5	104.2	50000	A703_104.2 S3 M3LA4	150	A703_104.2 P100 BN100LA4	151
13.9	1375	1.5	101.4	30000	A553_101.4 S3 M3LA4	142	A553_101.4 P100 BN100LA4	142
14.2	1350	1.1	99.5	20000	A503_99.5 S3 M3LA4	138	A503_99.5 P100 BN100LA4	139
14.2	1350	2.1	99.5	30000	A603_99.5 S3 M3LA4	146	A603_99.5 P100 BN100LA4	147
15.7	1215	1.2	89.5	19800	A503_89.5 S3 M3LA4	138	A503_89.5 P100 BN100LA4	139
16.3	1172	2.4	86.4	30000	A603_86.4 S3 M3LA4	146	A603_86.4 P100 BN100LA4	147
17.3	1105	1.4	81.5	19600	A503_81.5 S3 M3LA4	138	A503_81.5 P100 BN100LA4	139
17.7	1082	2.6	79.7	30000	A603_79.7 S3 M3LA4	146	A603_79.7 P100 BN100LA4	147
17.7	1079	1.9	79.5	30000	A553_79.5 S3 M3LA4	142	A553_79.5 P100 BN100LA4	142
20.0	955	2.9	70.4	30000	A603_70.4 S3 M3LA4	146	A603_70.4 P100 BN100LA4	147
20.1	953	1.6	70.2	19300	A503_70.2 S3 M3LA4	138	A503_70.2 P100 BN100LA4	139
21.7	882	3.2	65.0	30000	A603_65.0 S3 M3LA4	146	A603_65.0 P100 BN100LA4	147
21.9	873	2.3	64.3	30000	A553_64.3 S3 M3LA4	142	A553_64.3 P100 BN100LA4	142
22.0	899	0.9	64.2	14500	A412_64.2 S3 M3LA4	134	A412_64.2 P100 BN100LA4	135
22.1	867	1.7	63.9	19000	A503_63.9 S3 M3LA4	138	A503_63.9 P100 BN100LA4	139
24.0	824	1.0	58.8	14400	A412_58.8 S3 M3LA4	134	A412_58.8 P100 BN100LA4	135
24.8	771	1.9	56.8	18600	A503_56.8 S3 M3LA4	138	A503_56.8 P100 BN100LA4	139
26.5	745	1.1	53.1	14100	A412_53.1 S3 M3LA4	134	A412_53.1 P100 BN100LA4	135
27.3	701	2.1	51.7	18300	A503_51.7 S3 M3LA4	138	A503_51.7 P100 BN100LA4	139
27.7	691	2.9	51.0	30000	A553_51.0 S3 M3LA4	142	A553_51.0 P100 BN100LA4	142
28.7	688	0.9	49.1	9900	A352_49.1 S3 M3LA4	130	A352_49.1 P100 BN100LA4	131
29.2	677	1.3	48.3	13900	A412_48.3 S3 M3LA4	134	A412_48.3 P100 BN100LA4	135
31	642	0.9	45.8	9840	A352_45.8 S3 M3LA4	130	A352_45.8 P100 BN100LA4	131
31	632	1.3	45.1	13700	A412_45.1 S3 M3LA4	134	A412_45.1 P100 BN100LA4	135
31	611	2.5	45.0	17900	A503_45.0 S3 M3LA4	138	A503_45.0 P100 BN100LA4	139
34	586	1.0	41.8	9750	A352_41.8 S3 M3LA4	130	A352_41.8 P100 BN100LA4	131
34	555	2.7	40.9	17500	A503_40.9 S3 M3LA4	138	A503_40.9 P100 BN100LA4	139
38	513	1.2	36.6	9600	A352_36.6 S3 M3LA4	130	A352_36.6 P100 BN100LA4	131
39	503	1.6	35.9	13100	A412_35.9 S3 M3LA4	134	A412_35.9 P100 BN100LA4	135
40	483	3.1	35.6	17000	A503_35.6 S3 M3LA4	138	A503_35.6 P100 BN100LA4	139
43	465	1.3	33.2	9460	A352_33.2 S3 M3LA4	130	A352_33.2 P100 BN100LA4	131
44	439	3.4	32.4	16600	A503_32.4 S3 M3LA4	138	A503_32.4 P100 BN100LA4	139
48	411	1.0	29.3	5380	A302_29.3 S3 M3LA4	126	A302_29.3 P100 BN100LA4	127
50	399	1.5	28.4	9230	A352_28.4 S3 M3LA4	130	A352_28.4 P100 BN100LA4	131
50	397	1.8	28.3	12400	A412_28.3 S3 M3LA4	134	A412_28.3 P100 BN100LA4	135
53	372	1.1	26.5	5350	A302_26.5 S3 M3LA4	126	A302_26.5 P100 BN100LA4	127
55	360	1.7	25.7	9070	A352_25.7 S3 M3LA4	130	A352_25.7 P100 BN100LA4	131
62	319	1.3	22.8	5290	A302_22.8 S3 M3LA4	126	A302_22.8 P100 BN100LA4	127
62	318	2.1	22.7	11700	A412_22.7 S3 M3LA4	134	A412_22.7 P100 BN100LA4	135
63	315	1.9	22.5	8840	A352_22.5 S3 M3LA4	130	A352_22.5 P100 BN100LA4	131
69	288	1.4	20.5	5230	A302_20.5 S3 M3LA4	126	A302_20.5 P100 BN100LA4	127



2.2 kW

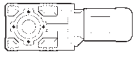

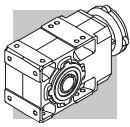

n ₂ min ⁻¹	M ₂ Nm	S	i	R _{n2} N			 IEC 	
69	286	2.1	20.4	8660	A352_20.4 S3 M3LA4	130	A352_20.4 P100 BN100LA4	131
78	254	1.0	18.1	3140	A202_18.1 S3 M3LA4	122	A202_18.1 P100 BN100LA4	123
78	252	1.6	18.0	5140	A302_18.0 S3 M3LA4	126	A302_18.0 P100 BN100LA4	127
79	249	2.5	17.8	11000	A412_17.8 S3 M3LA4	134	A412_17.8 P100 BN100LA4	135
83	238	2.5	17.0	8320	A352_17.0 S3 M3LA4	130	A352_17.0 P100 BN100LA4	131
86	229	1.7	16.3	5060	A302_16.3 S3 M3LA4	126	A302_16.3 P100 BN100LA4	127
87	227	1.1	16.2	3140	A202_16.2 S3 M3LA4	122	A202_16.2 P100 BN100LA4	123
88	226	2.7	16.1	10800	A412_16.1 S3 M3LA4	134	A412_16.1 P100 BN100LA4	135
91	217	2.8	15.5	8150	A352_15.5 S3 M3LA4	130	A352_15.5 P100 BN100LA4	131
100	197	1.2	14.1	3120	A202_14.1 S3 M3LA4	122	A202_14.1 P100 BN100LA4	123
102	193	3.0	13.8	10300	A412_13.8 S3 M3LA4	134	A412_13.8 P100 BN100LA4	135
104	190	1.9	13.6	4900	A302_13.6 S3 M3LA4	126	A302_13.6 P100 BN100LA4	127
108	183	3.3	13.1	7820	A352_13.1 S3 M3LA4	130	A352_13.1 P100 BN100LA4	131
118	168	1.3	12.0	3070	A202_12.0 S3 M3LA4	122	A202_12.0 P100 BN100LA4	123
120	165	1.8	11.8	4750	A302_11.8 S3 M3LA4	126	A302_11.8 P100 BN100LA4	127
120	165	2.4	11.8	7710	A352_11.8 S3 M3LA4	130	A352_11.8 P100 BN100LA4	131
120	165	3.3	11.7	9870	A412_11.7 S3 M3LA4	134	A412_11.7 P100 BN100LA4	135
123	160	2.0	23.1	3070	A202_23.1 S3 M3SA2	122	A202_23.1 P90 BN90L2	123
133	149	2.7	10.6	7510	A352_10.6 S3 M3LA4	130	A352_10.6 P100 BN100LA4	131
134	148	1.0	10.6	2600	A102_10.6 S3 M3LA4	118	A102_10.6 P100 BN100LA4	119
135	147	2.3	10.5	4660	A302_10.5 S3 M3LA4	126	A302_10.5 P100 BN100LA4	127
136	145	1.6	10.3	3030	A202_10.3 S3 M3LA4	122	A202_10.3 P100 BN100LA4	123
147	135	1.0	9.6	2580	A102_9.6 S3 M3LA4	118	A102_9.6 P100 BN100LA4	119
150	131	1.6	9.4	2980	A202_9.4 S3 M3LA4	122	A202_9.4 P100 BN100LA4	123
151	130	2.3	9.3	4530	A302_9.3 S3 M3LA4	126	A302_9.3 P100 BN100LA4	127
151	130	3.1	9.3	7240	A352_9.3 S3 M3LA4	130	A352_9.3 P100 BN100LA4	131
166	119	1.2	8.5	3050	A102_8.5 S3 M3LA4	118	A102_8.5 P100 BN100LA4	119
167	119	2.5	8.5	4430	A302_8.5 S3 M3LA4	126	A302_8.5 P100 BN100LA4	127
167	119	3.2	8.5	7060	A352_8.5 S3 M3LA4	130	A352_8.5 P100 BN100LA4	131
168	117	1.8	8.4	2930	A202_8.4 S3 M3LA4	122	A202_8.4 P100 BN100LA4	123
193	102	2.1	7.3	2860	A202_7.3 S3 M3LA4	122	A202_7.3 P100 BN100LA4	123
196	101	1.4	7.2	2520	A102_7.2 S3 M3LA4	118	A102_7.2 P100 BN100LA4	119
201	98	3.0	7.0	4240	A302_7.0 S3 M3LA4	126	A302_7.0 P100 BN100LA4	127
216	92	2.3	6.5	2810	A202_6.5 S3 M3LA4	122	A202_6.5 P100 BN100LA4	123
220	90	3.3	6.4	4150	A302_6.4 S3 M3LA4	126	A302_6.4 P100 BN100LA4	127
223	89	1.6	6.3	2950	A102_6.3 S3 M3LA4	118	A102_6.3 P100 BN100LA4	119
258	77	1.8	5.5	2430	A102_5.5 S3 M3LA4	118	A102_5.5 P100 BN100LA4	119
263	75	2.8	5.4	2700	A202_5.4 S3 M3LA4	122	A202_5.4 P100 BN100LA4	123
304	65	3.2	9.4	2620	A202_9.4 S3 M3SA2	122	A202_9.4 P90 BN90L2	123

3.0 kW

n ₂ min ⁻¹	M ₂ Nm	S	i	R _{n2} N			 IEC 	
1.6	15653	0.9	865.1	75000	A904_865.1 S3 M3LB4	156	A904_865.1 P100 BN100LB4	157
1.8	13876	1.0	766.9	75000	A904_766.9 S3 M3LB4	156	A904_766.9 P100 BN100LB4	157
2.0	12809	1.1	707.9	75000	A904_707.9 S3 M3LB4	156	A904_707.9 P100 BN100LB4	157
2.3	10885	1.3	601.6	75000	A904_601.6 S3 M3LB4	156	A904_601.6 P100 BN100LB4	157
2.5	10047	1.4	555.3	75000	A904_555.3 S3 M3LB4	156	A904_555.3 P100 BN100LB4	157
2.9	8804	1.6	486.6	75000	A904_486.6 S3 M3LB4	156	A904_486.6 P100 BN100LB4	157
2.9	8665	0.9	478.9	65000	A804_478.9 S3 M3LB4	153	A804_478.9 P100 BN100LB4	154
3.1	8127	1.7	449.2	75000	A904_449.2 S3 M3LB4	156	A904_449.2 P100 BN100LB4	157
3.2	7999	1.0	442.1	65000	A804_442.1 S3 M3LB4	153	A804_442.1 P100 BN100LB4	154
3.7	6974	2.0	385.4	75000	A904_385.4 S3 M3LB4	156	A904_385.4 P100 BN100LB4	157
3.7	6938	1.2	383.5	65000	A804_383.5 S3 M3LB4	153	A804_383.5 P100 BN100LB4	154
4.0	6438	2.2	355.8	75000	A904_355.8 S3 M3LB4	156	A904_355.8 P100 BN100LB4	157
4.0	6405	1.2	354.0	65000	A804_354.0 S3 M3LB4	153	A804_354.0 P100 BN100LB4	154
4.5	5724	0.9	316.4	50000	A704_316.4 S3 M3LB4	150	A704_316.4 P100 BN100LB4	151
4.6	5517	2.5	304.9	75000	A904_304.9 S3 M3LB4	156	A904_304.9 P100 BN100LB4	157
4.7	5435	1.5	300.4	65000	A804_300.4 S3 M3LB4	153	A804_300.4 P100 BN100LB4	154
4.8	5284	0.9	292.0	50000	A704_292.0 S3 M3LB4	150	A704_292.0 P100 BN100LB4	151
5.0	5092	2.7	281.4	75000	A904_281.4 S3 M3LB4	156	A904_281.4 P100 BN100LB4	157
5.1	5017	1.6	277.3	65000	A804_277.3 S3 M3LB4	153	A804_277.3 P100 BN100LB4	154





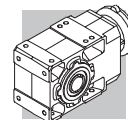

3.0 kW





n ₂ min ⁻¹	M ₂ Nm	S	i	R _{n2} N				
5.9	4317	1.2	238.6	50000	A704_238.6 S3 M3LB4	150	A704_238.6 P100 BN100LB4	151
6.1	4209	1.9	232.6	65000	A804_232.6 S3 M3LB4	153	A804_232.6 P100 BN100LB4	154
6.2	4097	3.4	226.4	75000	A904_226.4 S3 M3LB4	156	A904_226.4 P100 BN100LB4	157
6.4	3985	1.3	220.3	50000	A704_220.3 S3 M3LB4	150	A704_220.3 P100 BN100LB4	151
6.6	3885	2.1	214.7	65000	A804_214.7 S3 M3LB4	153	A804_214.7 P100 BN100LB4	154
7.7	3327	1.5	183.9	50000	A704_183.9 S3 M3LB4	150	A704_183.9 P100 BN100LB4	151
8.2	3172	0.9	171.5	30000	A603_171.5 S3 M3LB4	146	A603_171.5 P100 BN100LB4	147
8.2	3099	2.6	171.3	65000	A804_171.3 S3 M3LB4	153	A804_171.3 P100 BN100LB4	154
8.3	3071	1.6	169.8	50000	A704_169.8 S3 M3LB4	150	A704_169.8 P100 BN100LB4	151
9.0	2901	2.8	156.8	65000	A803_156.8 S3 M3LB4	153	A803_156.8 P100 BN100LB4	154
9.0	2887	1.0	156.0	30000	A603_156.0 S3 M3LB4	146	A603_156.0 P100 BN100LB4	147
9.2	2843	1.4	153.7	50000	A703_153.7 S3 M3LB4	150	A703_153.7 P100 BN100LB4	151
9.7	2678	3.0	144.7	65000	A803_144.7 S3 M3LB4	153	A803_144.7 P100 BN100LB4	154
9.8	2665	1.1	144.0	30000	A603_144.0 S3 M3LB4	146	A603_144.0 P100 BN100LB4	147
9.9	2624	1.9	141.9	50000	A703_141.9 S3 M3LB4	150	A703_141.9 P100 BN100LB4	151
10.6	2466	1.1	133.3	30000	A603_133.3 S3 M3LB4	146	A603_133.3 P100 BN100LB4	147
10.8	2417	2.1	130.7	50000	A703_130.7 S3 M3LB4	150	A703_130.7 P100 BN100LB4	151
11.2	2324	3.4	125.6	65000	A803_125.6 S3 M3LB4	153	A803_125.6 P100 BN100LB4	154
11.5	2276	1.2	123.0	30000	A603_123.0 S3 M3LB4	146	A603_123.0 P100 BN100LB4	147
11.7	2231	2.2	120.6	50000	A703_120.6 S3 M3LB4	150	A703_120.6 P100 BN100LB4	151
13.1	1994	1.4	107.8	30000	A603_107.8 S3 M3LB4	146	A603_107.8 P100 BN100LB4	147
13.5	1928	2.6	104.2	50000	A703_104.2 S3 M3LB4	150	A703_104.2 P100 BN100LB4	151
13.9	1876	1.1	101.4	30000	A553_101.4 S3 M3LB4	142	A553_101.4 P100 BN100LB4	142
14.2	1841	1.5	99.5	30000	A603_99.5 S3 M3LB4	146	A603_99.5 P100 BN100LB4	147
14.7	1780	2.8	96.2	50000	A703_96.2 S3 M3LB4	150	A703_96.2 P100 BN100LB4	151
15.7	1657	0.9	89.5	17100	A503_89.5 S3 M3LB4	138	A503_89.5 P100 BN100LB4	139
16.3	1598	1.8	86.4	30000	A603_86.4 S3 M3LB4	146	A603_86.4 P100 BN100LB4	147
16.4	1590	3.1	85.9	50000	A703_85.9 S3 M3LB4	150	A703_85.9 P100 BN100LB4	151
17.3	1507	1.0	81.5	17200	A503_81.5 S3 M3LB4	138	A503_81.5 P100 BN100LB4	139
17.7	1475	1.9	79.7	30000	A603_79.7 S3 M3LB4	146	A603_79.7 P100 BN100LB4	147
17.7	1471	1.4	79.5	30000	A553_79.5 S3 M3LB4	142	A553_79.5 P100 BN100LB4	142
17.8	1468	3.4	79.3	50000	A703_79.3 S3 M3LB4	150	A703_79.3 P100 BN100LB4	151
20.0	1303	2.1	70.4	30000	A603_70.4 S3 M3LB4	146	A603_70.4 P100 BN100LB4	147
20.1	1299	1.2	70.2	17200	A503_70.2 S3 M3LB4	138	A503_70.2 P100 BN100LB4	139
21.7	1202	2.3	65.0	30000	A603_65.0 S3 M3LB4	146	A603_65.0 P100 BN100LB4	147
21.9	1190	1.7	64.3	30000	A553_64.3 S3 M3LB4	142	A553_64.3 P100 BN100LB4	142
22.1	1182	1.3	63.9	17100	A503_63.9 S3 M3LB4	138	A503_63.9 P100 BN100LB4	139
24.8	1051	1.4	56.8	17000	A503_56.8 S3 M3LB4	138	A503_56.8 P100 BN100LB4	139
25.4	1029	2.7	55.6	30000	A603_55.6 S3 M3LB4	146	A603_55.6 P100 BN100LB4	147
27.3	956	1.6	51.7	16800	A503_51.7 S3 M3LB4	138	A503_51.7 P100 BN100LB4	139
27.5	950	2.9	51.3	30000	A603_51.3 S3 M3LB4	146	A603_51.3 P100 BN100LB4	147
27.7	943	2.1	51.0	30000	A553_51.0 S3 M3LB4	142	A553_51.0 P100 BN100LB4	142
29.2	923	0.9	48.3	12700	A412_48.3 S3 M3LB4	134	A412_48.3 P100 BN100LB4	135
31	861	1.0	45.1	12600	A412_45.1 S3 M3LB4	134	A412_45.1 P100 BN100LB4	135
31	836	3.3	45.2	30000	A603_45.2 S3 M3LB4	146	A603_45.2 P100 BN100LB4	147
31	833	1.8	45.0	16500	A503_45.0 S3 M3LB4	138	A503_45.0 P100 BN100LB4	139
34	757	2.0	40.9	16300	A503_40.9 S3 M3LB4	138	A503_40.9 P100 BN100LB4	139
35	746	2.7	40.3	30000	A553_40.3 S3 M3LB4	142	A553_40.3 P100 BN100LB4	142
38	700	0.9	36.6	8550	A352_36.6 S3 M3LB4	130	A352_36.6 P100 BN100LB4	131
39	686	1.1	35.9	12200	A412_35.9 S3 M3LB4	134	A412_35.9 P100 BN100LB4	135
40	659	2.3	35.6	16000	A503_35.6 S3 M3LB4	138	A503_35.6 P100 BN100LB4	139
43	634	0.9	33.2	8520	A352_33.2 S3 M3LB4	130	A352_33.2 P100 BN100LB4	131
44	599	2.5	32.4	15700	A503_32.4 S3 M3LB4	138	A503_32.4 P100 BN100LB4	139
50	543	1.1	28.4	8420	A352_28.4 S3 M3LB4	130	A352_28.4 P100 BN100LB4	131
50	541	1.3	28.3	11700	A412_28.3 S3 M3LB4	134	A412_28.3 P100 BN100LB4	135
53	489	3.1	26.4	15100	A503_26.4 S3 M3LB4	138	A503_26.4 P100 BN100LB4	139
55	491	1.2	25.7	8330	A352_25.7 S3 M3LB4	130	A352_25.7 P100 BN100LB4	131
59	445	3.4	24.0	14800	A503_24.0 S3 M3LB4	138	A503_24.0 P100 BN100LB4	139
62	435	0.9	22.8	4610	A302_22.8 S3 M3LB4	126	A302_22.8 P100 BN100LB4	127
62	433	1.6	22.7	11200	A412_22.7 S3 M3LB4	134	A412_22.7 P100 BN100LB4	135
63	430	1.4	22.5	8190	A352_22.5 S3 M3LB4	130	A352_22.5 P100 BN100LB4	131
67	400	3.0	20.9	15500	A502_20.9 S3 M3LB4	138	A502_20.9 P100 BN100LB4	139
69	392	1.0	20.5	4620	A302_20.5 S3 M3LB4	126	A302_20.5 P100 BN100LB4	127
69	390	1.5	20.4	8080	A352_20.4 S3 M3LB4	130	A352_20.4 P100 BN100LB4	131
78	344	1.2	18.0	4600	A302_18.0 S3 M3LB4	126	A302_18.0 P100 BN100LB4	127
79	339	1.9	17.8	10600	A412_17.8 S3 M3LB4	134	A412_17.8 P100 BN100LB4	135



3.0 kW

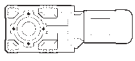

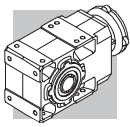

n ₂ min ⁻¹	M ₂ Nm	S	i	R _{n2} N				
83	324	1.9	17.0	7830	A352_17.0 S3 M3LB4	130	A352_17.0 P100 BN100LB4	131
86	312	1.2	16.3	4580	A302_16.3 S3 M3LB4	126	A302_16.3 P100 BN100LB4	127
88	308	2.0	16.1	10400	A412_16.1 S3 M3LB4	134	A412_16.1 P100 BN100LB4	135
91	296	2.0	15.5	7700	A352_15.5 S3 M3LB4	130	A352_15.5 P100 BN100LB4	131
100	269	0.9	14.1	2650	A202_14.1 S3 M3LB4	122	A202_14.1 P100 BN100LB4	123
102	263	2.2	13.8	9990	A412_13.8 S3 M3LB4	134	A412_13.8 P100 BN100LB4	135
104	259	1.4	13.6	4500	A302_13.6 S3 M3LB4	126	A302_13.6 P100 BN100LB4	127
108	250	2.4	13.1	7450	A352_13.1 S3 M3LB4	130	A352_13.1 P100 BN100LB4	131
118	229	0.9	12.0	2670	A202_12.0 S3 M3LB4	122	A202_12.0 P100 BN100LB4	123
120	225	1.3	11.8	4400	A302_11.8 S3 M3LB4	126	A302_11.8 P100 BN100LB4	127
120	225	1.8	11.8	7410	A352_11.8 S3 M3LB4	130	A352_11.8 P100 BN100LB4	131
120	224	2.5	11.7	9580	A412_11.7 S3 M3LB4	134	A412_11.7 P100 BN100LB4	135
124	218	1.5	23.1	2690	A202_23.1 S3 M3LA2	122	A202_23.1 P100 BN100L2	123
133	203	2.0	10.6	7230	A352_10.6 S3 M3LB4	130	A352_10.6 P100 BN100LB4	131
135	200	1.7	10.5	4350	A302_10.5 S3 M3LB4	126	A302_10.5 P100 BN100LB4	127
136	198	1.1	10.3	2690	A202_10.3 S3 M3LB4	122	A202_10.3 P100 BN100LB4	123
139	194	2.8	10.1	9230	A412_10.1 S3 M3LB4	134	A412_10.1 P100 BN100LB4	135
150	179	1.2	9.4	2670	A202_9.4 S3 M3LB4	122	A202_9.4 P100 BN100LB4	123
151	178	1.7	9.3	4240	A302_9.3 S3 M3LB4	126	A302_9.3 P100 BN100LB4	127
151	178	2.2	9.3	7000	A352_9.3 S3 M3LB4	130	A352_9.3 P100 BN100LB4	131
153	176	3.1	9.2	8980	A412_9.2 S3 M3LB4	134	A412_9.2 P100 BN100LB4	135
167	162	1.9	8.5	4170	A302_8.5 S3 M3LB4	126	A302_8.5 P100 BN100LB4	127
167	162	2.4	8.5	6840	A352_8.5 S3 M3LB4	130	A352_8.5 P100 BN100LB4	131
168	160	1.3	8.4	2650	A202_8.4 S3 M3LB4	122	A202_8.4 P100 BN100LB4	123
169	159	3.5	8.3	8740	A412_8.3 S3 M3LB4	134	A412_8.3 P100 BN100LB4	135
193	139	1.5	7.3	2620	A202_7.3 S3 M3LB4	122	A202_7.3 P100 BN100LB4	123
196	138	1.0	7.2	2220	A102_7.2 S3 M3LB4	118	A102_7.2 P100 BN100LB4	119
201	134	2.2	7.0	4030	A302_7.0 S3 M3LB4	126	A302_7.0 P100 BN100LB4	127
201	134	2.8	7.0	6520	A352_7.0 S3 M3LB4	130	A352_7.0 P100 BN100LB4	131
216	125	1.7	6.5	2590	A202_6.5 S3 M3LB4	122	A202_6.5 P100 BN100LB4	123
220	123	2.4	6.4	3950	A302_6.4 S3 M3LB4	126	A302_6.4 P100 BN100LB4	127
220	123	2.9	6.4	6360	A352_6.4 S3 M3LB4	130	A352_6.4 P100 BN100LB4	131
223	121	1.2	6.3	2640	A102_6.3 S3 M3LB4	118	A102_6.3 P100 BN100LB4	119
243	111	2.7	11.8	3870	A302_11.8 S3 M3LA2	126	A302_11.8 P100 BN100L2	127
258	104	1.3	5.5	2200	A102_5.5 S3 M3LB4	118	A102_5.5 P100 BN100LB4	119
260	103	2.9	5.4	3810	A302_5.4 S3 M3LB4	126	A302_5.4 P100 BN100LB4	127
260	103	3.3	5.4	6070	A352_5.4 S3 M3LB4	130	A352_5.4 P100 BN100LB4	131
263	102	2.1	5.4	2520	A202_5.4 S3 M3LB4	122	A202_5.4 P100 BN100LB4	123
277	97	1.9	10.3	2500	A202_10.3 S3 M3LA2	122	A202_10.3 P100 BN100L2	123
307	88	3.4	9.3	3670	A302_9.3 S3 M3LA2	126	A302_9.3 P100 BN100L2	127
342	79	2.7	8.4	2410	A202_8.4 S3 M3LA2	122	A202_8.4 P100 BN100L2	123
397	68	2.1	7.2	2090	A102_7.2 S3 M3LA2	118	A102_7.2 P100 BN100L2	119
451	60	2.3	6.3	2430	A102_6.3 S3 M3LA2	118	A102_6.3 P100 BN100L2	119
523	51	2.6	5.5	1990	A102_5.5 S3 M3LA2	118	A102_5.5 P100 BN100L2	119

4.0 kW

n ₂ min ⁻¹	M ₂ Nm	S	i	R _{n2} N				
2.3	14616	1.0	601.6	75000	A904_601.6 S3 M3LC4	156	A904_601.6 P112 BN112M4	157
2.5	13492	1.0	555.3	75000	A904_555.3 S3 M3LC4	156	A904_555.3 P112 BN112M4	157
2.9	11823	1.2	486.6	75000	A904_486.6 S3 M3LC4	156	A904_486.6 P112 BN112M4	157
3.1	10913	1.3	449.2	75000	A904_449.2 S3 M3LC4	156	A904_449.2 P112 BN112M4	157
3.6	9365	1.5	385.4	75000	A904_385.4 S3 M3LC4	156	A904_385.4 P112 BN112M4	157
3.7	9317	0.9	383.5	65000	A804_383.5 S3 M3LC4	153	A804_383.5 P112 BN112M4	154
3.9	8645	1.6	355.8	75000	A904_355.8 S3 M3LC4	156	A904_355.8 P112 BN112M4	157
4.0	8600	0.9	354.0	65000	A804_354.0 S3 M3LC4	153	A804_354.0 P112 BN112M4	154
4.6	7408	1.9	304.9	75000	A904_304.9 S3 M3LC4	156	A904_304.9 P112 BN112M4	157
4.7	7299	1.1	300.4	65000	A804_300.4 S3 M3LC4	153	A804_300.4 P112 BN112M4	154
5.0	6838	2.0	281.4	75000	A904_281.4 S3 M3LC4	156	A904_281.4 P112 BN112M4	157
5.0	6737	1.2	277.3	65000	A804_277.3 S3 M3LC4	153	A804_277.3 P112 BN112M4	154
5.9	5797	0.9	238.6	50000	A704_238.6 S3 M3LC4	150	A704_238.6 P112 BN112M4	151
6.0	5652	1.4	232.6	65000	A804_232.6 S3 M3LC4	153	A804_232.6 P112 BN112M4	154





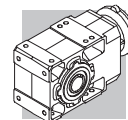

4.0 kW



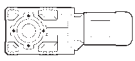

n ₂ min ⁻¹	M ₂ Nm	S	i	R _{n2} N				
6.2	5502	2.5	226.4	75000	A904_226.4 S3 M3LC4	156	A904_226.4 P112 BN112M4	157
6.4	5352	0.9	220.3	50000	A704_220.3 S3 M3LC4	150	A704_220.3 P112 BN112M4	151
6.5	5217	1.5	214.7	65000	A804_214.7 S3 M3LC4	153	A804_214.7 P112 BN112M4	154
6.7	5078	2.8	209.0	75000	A904_209.0 S3 M3LC4	156	A904_209.0 P112 BN112M4	157
7.6	4468	1.1	183.9	50000	A704_183.9 S3 M3LC4	150	A704_183.9 P112 BN112M4	151
7.8	4373	3.2	180.0	75000	A904_180.0 S3 M3LC4	156	A904_180.0 P112 BN112M4	157
8.2	4162	1.9	171.3	65000	A804_171.3 S3 M3LC4	153	A804_171.3 P112 BN112M4	154
8.2	4125	1.2	169.8	50000	A704_169.8 S3 M3LC4	150	A704_169.8 P112 BN112M4	151
8.4	4036	3.5	166.1	75000	A904_166.1 S3 M3LC4	156	A904_166.1 P112 BN112M4	157
8.9	3895	2.1	156.8	65000	A803_156.8 S3 M3LC4	153	A803_156.8 P112 BN112M4	154
9.1	3818	1.1	153.7	50000	A703_153.7 S3 M3LC4	150	A703_153.7 P112 BN112M4	151
9.7	3596	2.2	144.7	65000	A803_144.7 S3 M3LC4	153	A803_144.7 P112 BN112M4	154
9.9	3524	1.4	141.9	50000	A703_141.9 S3 M3LC4	150	A703_141.9 P112 BN112M4	151
10.7	3246	1.5	130.7	50000	A703_130.7 S3 M3LC4	150	A703_130.7 P112 BN112M4	151
11.1	3121	2.6	125.6	65000	A803_125.6 S3 M3LC4	153	A803_125.6 P112 BN112M4	154
11.4	3056	0.9	123.0	30000	A603_123.0 S3 M3LC4	146	A603_123.0 P112 BN112M4	147
11.6	2996	1.7	120.6	50000	A703_120.6 S3 M3LC4	150	A703_120.6 P112 BN112M4	151
12.1	2881	2.8	116.0	65000	A803_116.0 S3 M3LC4	153	A803_116.0 P112 BN112M4	154
13.0	2678	1.0	107.8	30000	A603_107.8 S3 M3LC4	146	A603_107.8 P112 BN112M4	147
13.4	2590	1.9	104.2	50000	A703_104.2 S3 M3LC4	150	A703_104.2 P112 BN112M4	151
13.5	2584	3.1	104.0	65000	A803_104.0 S3 M3LC4	153	A803_104.0 P112 BN112M4	154
14.1	2472	1.1	99.5	30000	A603_99.5 S3 M3LC4	146	A603_99.5 P112 BN112M4	147
14.6	2390	2.1	96.2	50000	A703_96.2 S3 M3LC4	150	A703_96.2 P112 BN112M4	151
14.6	2386	3.4	96.0	65000	A803_96.0 S3 M3LC4	153	A803_96.0 P112 BN112M4	154
16.2	2146	1.3	86.4	30000	A603_86.4 S3 M3LC4	146	A603_86.4 P112 BN112M4	147
16.3	2135	2.3	85.9	50000	A703_85.9 S3 M3LC4	150	A703_85.9 P112 BN112M4	151
17.6	1980	1.4	79.7	30000	A603_79.7 S3 M3LC4	146	A603_79.7 P112 BN112M4	147
17.6	1976	1.0	79.5	30000	A553_79.5 S3 M3LC4	142	A553_79.5 P112 BN112M4	142
17.6	1971	2.5	79.3	50000	A703_79.3 S3 M3LC4	150	A703_79.3 P112 BN112M4	151
19.3	1802	2.8	72.5	50000	A703_72.5 S3 M3LC4	150	A703_72.5 P112 BN112M4	151
19.9	1749	1.6	70.4	30000	A603_70.4 S3 M3LC4	146	A603_70.4 P112 BN112M4	147
20.9	1663	3.0	66.9	50000	A703_66.9 S3 M3LC4	150	A703_66.9 P112 BN112M4	151
21.5	1615	1.7	65.0	30000	A603_65.0 S3 M3LC4	146	A603_65.0 P112 BN112M4	147
21.8	1598	1.3	64.3	30000	A553_64.3 S3 M3LC4	142	A553_64.3 P112 BN112M4	142
21.9	1587	0.9	63.9	14700	A503_63.9 S3 M3LC4	138	A503_63.9 P112 BN112M4	139
24.6	1411	1.1	56.8	14800	A503_56.8 S3 M3LC4	138	A503_56.8 P112 BN112M4	139
25.2	1381	2.0	55.6	30000	A603_55.6 S3 M3LC4	146	A603_55.6 P112 BN112M4	147
27.1	1284	1.2	51.7	14900	A503_51.7 S3 M3LC4	138	A503_51.7 P112 BN112M4	139
27.3	1275	2.2	51.3	30000	A603_51.3 S3 M3LC4	146	A603_51.3 P112 BN112M4	147
28	1266	1.6	51.0	30000	A553_51.0 S3 M3LC4	142	A553_51.0 P112 BN112M4	142
31	1123	2.5	45.2	30000	A603_45.2 S3 M3LC4	146	A603_45.2 P112 BN112M4	147
31	1118	1.3	45.0	14900	A503_45.0 S3 M3LC4	138	A503_45.0 P112 BN112M4	139
34	1036	2.7	41.7	30000	A603_41.7 S3 M3LC4	146	A603_41.7 P112 BN112M4	147
34	1017	1.5	40.9	14800	A503_40.9 S3 M3LC4	138	A503_40.9 P112 BN112M4	139
35	1001	2.0	40.3	30000	A553_40.3 S3 M3LC4	142	A553_40.3 P112 BN112M4	142
39	884	1.7	35.6	14700	A503_35.6 S3 M3LC4	138	A503_35.6 P112 BN112M4	139
41	852	3.3	34.3	30000	A603_34.3 S3 M3LC4	146	A603_34.3 P112 BN112M4	147
43	804	1.9	32.4	14500	A503_32.4 S3 M3LC4	138	A503_32.4 P112 BN112M4	139
47	744	2.7	29.9	30000	A553_29.9 S3 M3LC4	142	A553_29.9 P112 BN112M4	142
49	727	1.0	28.3	10900	A412_28.3 S3 M3LC4	134	A412_28.3 P112 BN112M4	135
53	657	2.3	26.4	14100	A503_26.4 S3 M3LC4	138	A503_26.4 P112 BN112M4	139
55	659	0.9	25.7	7420	A352_25.7 S3 M3LC4	130	A352_25.7 P112 BN112M4	131
58	597	2.5	24.0	13900	A503_24.0 S3 M3LC4	138	A503_24.0 P112 BN112M4	139
59	591	3.3	23.8	30000	A553_23.8 S3 M3LC4	142	A553_23.8 P112 BN112M4	142
62	582	1.2	22.7	10500	A412_22.7 S3 M3LC4	134	A412_22.7 P112 BN112M4	135
62	577	1.0	22.5	7400	A352_22.5 S3 M3LC4	130	A352_22.5 P112 BN112M4	131
67	537	2.2	20.9	15100	A502_20.9 S3 M3LC4	138	A502_20.9 P112 BN112M4	139
69	524	1.1	20.4	7360	A352_20.4 S3 M3LC4	130	A352_20.4 P112 BN112M4	131
78	462	0.9	18.0	3930	A302_18.0 S3 M3LC4	126	A302_18.0 P112 BN112M4	127
79	456	1.4	17.8	10100	A412_17.8 S3 M3LC4	134	A412_17.8 P112 BN112M4	135
83	435	1.4	17.0	7240	A352_17.0 S3 M3LC4	130	A352_17.0 P112 BN112M4	131
84	425	2.8	16.6	14200	A502_16.6 S3 M3LC4	138	A502_16.6 P112 BN112M4	139
86	419	0.9	16.3	3970	A302_16.3 S3 M3LC4	126	A302_16.3 P112 BN112M4	127
87	413	1.5	16.1	9940	A412_16.1 S3 M3LC4	134	A412_16.1 P112 BN112M4	135
90	397	1.5	15.5	7160	A352_15.5 S3 M3LC4	130	A352_15.5 P112 BN112M4	131
102	353	1.7	13.8	9610	A412_13.8 S3 M3LC4	134	A412_13.8 P112 BN112M4	135



4.0 kW



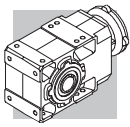

n_2 min ⁻¹	M_2 Nm	S	i	R_{n2} N			 IEC 	
103	348	1.1	13.6	4000	A302_13.6 S3 M3LC4	126	A302_13.6 P112 BN112M4	127
107	336	3.3	13.1	13300	A502_13.1 S3 M3LC4	138	A502_13.1 P112 BN112M4	139
107	335	1.8	13.1	7000	A352_13.1 S3 M3LC4	130	A352_13.1 P112 BN112M4	131
119	302	1.0	11.8	3960	A302_11.8 S3 M3LC4	126	A302_11.8 P112 BN112M4	127
119	302	1.3	11.8	7050	A352_11.8 S3 M3LC4	130	A352_11.8 P112 BN112M4	131
119	301	1.8	11.7	9260	A412_11.7 S3 M3LC4	134	A412_11.7 P112 BN112M4	135
126	285	1.2	22.8	3980	A302_22.8 S3 M3LB2	126	A302_22.8 P112 BN112M2	127
132	273	1.5	10.6	6910	A352_10.6 S3 M3LC4	130	A352_10.6 P112 BN112M4	131
134	268	1.3	10.5	3970	A302_10.5 S3 M3LC4	126	A302_10.5 P112 BN112M4	127
138	260	2.1	10.1	8960	A412_10.1 S3 M3LC4	134	A412_10.1 P112 BN112M4	135
150	239	1.3	9.3	3900	A302_9.3 S3 M3LC4	126	A302_9.3 P112 BN112M4	127
150	239	1.7	9.3	6730	A352_9.3 S3 M3LC4	130	A352_9.3 P112 BN112M4	131
152	236	2.3	9.2	8740	A412_9.2 S3 M3LC4	134	A412_9.2 P112 BN112M4	135
165	217	1.4	8.5	3860	A302_8.5 S3 M3LC4	126	A302_8.5 P112 BN112M4	127
165	217	1.8	8.5	6590	A352_8.5 S3 M3LC4	130	A352_8.5 P112 BN112M4	131
167	215	1.0	8.4	2300	A202_8.4 S3 M3LC4	122	A202_8.4 P112 BN112M4	123
168	214	2.6	8.3	8520	A412_8.3 S3 M3LC4	134	A412_8.3 P112 BN112M4	135
192	187	1.1	7.3	2310	A202_7.3 S3 M3LC4	122	A202_7.3 P112 BN112M4	123
197	183	3.0	7.1	8180	A412_7.1 S3 M3LC4	134	A412_7.1 P112 BN112M4	135
199	180	1.7	7.0	3770	A302_7.0 S3 M3LC4	126	A302_7.0 P112 BN112M4	127
199	180	2.1	7.0	6310	A352_7.0 S3 M3LC4	130	A352_7.0 P112 BN112M4	131
214	168	1.3	6.5	2310	A202_6.5 S3 M3LC4	122	A202_6.5 P112 BN112M4	123
218	165	1.8	6.4	3720	A302_6.4 S3 M3LC4	126	A302_6.4 P112 BN112M4	127
218	165	2.1	6.4	6180	A352_6.4 S3 M3LC4	130	A352_6.4 P112 BN112M4	131
256	140	1.0	5.5	1910	A102_5.5 S3 M3LC4	118	A102_5.5 P112 BN112M4	119
259	139	2.2	5.4	3610	A302_5.4 S3 M3LC4	126	A302_5.4 P112 BN112M4	127
259	139	2.4	5.4	5920	A352_5.4 S3 M3LC4	130	A352_5.4 P112 BN112M4	131
262	137	1.5	5.4	2300	A202_5.4 S3 M3LC4	122	A202_5.4 P112 BN112M4	123
270	133	3.0	10.6	5850	A352_10.6 S3 M3LB2	130	A352_10.6 P112 BN112M2	131
308	117	3.4	9.3	5650	A352_9.3 S3 M3LB2	130	A352_9.3 P112 BN112M2	131
343	105	2.1	8.4	2230	A202_8.4 S3 M3LB2	122	A202_8.4 P112 BN112M2	123
409	88	3.4	7.0	3280	A302_7.0 S3 M3LB2	126	A302_7.0 P112 BN112M2	127
453	79	1.7	6.3	2240	A102_6.3 S3 M3LB2	118	A102_6.3 P112 BN112M2	119
536	67	2.8	5.4	2080	A202_5.4 S3 M3LB2	122	A202_5.4 P112 BN112M2	123

5.5 kW

n_2 min ⁻¹	M_2 Nm	S	i	R_{n2} N			 IEC 	
3.0	15805	0.9	486.6	75000	A904_486.6 S4 M4SA4	156	A904_486.6 P132 BN132S4	157
3.2	14589	1.0	449.2	75000	A904_449.2 S4 M4SA4	156	A904_449.2 P132 BN132S4	157
3.7	12519	1.1	385.4	75000	A904_385.4 S4 M4SA4	156	A904_385.4 P132 BN132S4	157
4.0	11556	1.2	355.8	75000	A904_355.8 S4 M4SA4	156	A904_355.8 P132 BN132S4	157
4.7	9903	1.4	304.9	75000	A904_304.9 S4 M4SA4	156	A904_304.9 P132 BN132S4	157
5.1	9141	1.5	281.4	75000	A904_281.4 S4 M4SA4	156	A904_281.4 P132 BN132S4	157
5.2	9006	0.9	277.3	65000	A804_277.3 S4 M4SA4	153	A804_277.3 P132 BN132S4	154
6.2	7556	1.1	232.6	65000	A804_232.6 S4 M4SA4	153	A804_232.6 P132 BN132S4	154
6.4	7354	1.9	226.4	75000	A904_226.4 S4 M4SA4	156	A904_226.4 P132 BN132S4	157
6.7	6975	1.1	214.7	65000	A804_214.7 S4 M4SA4	153	A804_214.7 P132 BN132S4	154
6.9	6789	2.1	209.0	75000	A904_209.0 S4 M4SA4	156	A904_209.0 P132 BN132S4	157
8.0	5846	2.4	180.0	75000	A904_180.0 S4 M4SA4	156	A904_180.0 P132 BN132S4	157
8.4	5564	1.4	171.3	65000	A804_171.3 S4 M4SA4	153	A804_171.3 P132 BN132S4	154
8.5	5514	0.9	169.8	50000	A704_169.8 S4 M4SA4	150	A704_169.8 P132 BN132S4	151
8.7	5396	2.6	166.1	75000	A904_166.1 S4 M4SA4	156	A904_166.1 P132 BN132S4	157
9.2	5207	1.5	156.8	65000	A803_156.8 S4 M4SA4	153	A803_156.8 P132 BN132S4	154
9.5	5015	2.8	151.0	75000	A903_151.0 S4 M4SA4	156	A903_151.0 P132 BN132S4	157
9.9	4807	1.7	144.7	65000	A803_144.7 S4 M4SA4	153	A803_144.7 P132 BN132S4	154
10.2	4711	1.1	141.9	50000	A703_141.9 S4 M4SA4	150	A703_141.9 P132 BN132S4	151
10.3	4629	2.8	139.4	75000	A903_139.4 S4 M4SA4	156	A903_139.4 P132 BN132S4	157
11.0	4339	1.2	130.7	50000	A703_130.7 S4 M4SA4	150	A703_130.7 P132 BN132S4	151
11.4	4206	3.1	126.6	75000	A903_126.6 S4 M4SA4	156	A903_126.6 P132 BN132S4	157
11.5	4172	1.9	125.6	65000	A803_125.6 S4 M4SA4	153	A803_125.6 P132 BN132S4	154
11.9	4006	1.2	120.6	50000	A703_120.6 S4 M4SA4	150	A703_120.6 P132 BN132S4	151





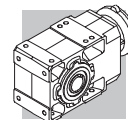

5.5 kW

n ₂ min ⁻¹	M ₂ Nm	S	i	R _{n2} N				
12.4	3851	2.1	116.0	65000	A803_116.0 S4 M4SA4	153	A803_116.0 P132 BN132SA4	154
13.8	3462	1.4	104.2	50000	A703_104.2 S4 M4SA4	150	A703_104.2 P132 BN132SA4	151
13.8	3455	2.3	104.0	65000	A803_104.0 S4 M4SA4	153	A803_104.0 P132 BN132SA4	154
15.0	3195	1.6	96.2	50000	A703_96.2 S4 M4SA4	150	A703_96.2 P132 BN132SA4	151
15.0	3189	2.5	96.0	65000	A803_96.0 S4 M4SA4	153	A803_96.0 P132 BN132SA4	154
16.1	2962	2.7	89.2	65000	A803_89.2 S4 M4SA4	153	A803_89.2 P132 BN132SA4	154
16.7	2868	1.0	86.4	30000	A603_86.4 S4 M4SA4	146	A603_86.4 P132 BN132SA4	147
16.8	2854	1.8	85.9	50000	A703_85.9 S4 M4SA4	150	A703_85.9 P132 BN132SA4	151
17.5	2734	2.9	82.3	65000	A803_82.3 S4 M4SA4	153	A803_82.3 P132 BN132SA4	154
18.1	2648	1.1	79.7	30000	A603_79.7 S4 M4SA4	146	A603_79.7 P132 BN132SA4	147
18.2	2635	1.9	79.3	50000	A703_79.3 S4 M4SA4	150	A703_79.3 P132 BN132SA4	151
19.9	2408	2.1	72.5	50000	A703_72.5 S4 M4SA4	150	A703_72.5 P132 BN132SA4	151
19.9	2403	3.3	72.4	65000	A803_72.4 S4 M4SA4	153	A803_72.4 P132 BN132SA4	154
20.5	2338	1.2	70.4	30000	A603_70.4 S4 M4SA4	146	A603_70.4 P132 BN132SA4	147
21.5	2223	2.2	66.9	50000	A703_66.9 S4 M4SA4	150	A703_66.9 P132 BN132SA4	151
22.2	2158	1.3	65.0	30000	A603_65.0 S4 M4SA4	146	A603_65.0 P132 BN132SA4	147
22.4	2136	0.9	64.3	30000	A553_64.3 S4 M4SA4	142	A553_64.3 P132 BN132SA4	142
25.0	1915	2.6	57.7	50000	A703_57.7 S4 M4SA4	150	A703_57.7 P132 BN132SA4	151
25.9	1847	1.5	55.6	30000	A603_55.6 S4 M4SA4	146	A603_55.6 P132 BN132SA4	147
27.1	1768	2.8	53.2	50000	A703_53.2 S4 M4SA4	150	A703_53.2 P132 BN132SA4	151
28.1	1705	1.6	51.3	30000	A603_51.3 S4 M4SA4	146	A603_51.3 P132 BN132SA4	147
28.3	1692	1.2	51.0	30000	A553_51.0 S4 M4SA4	142	A553_51.0 P132 BN132SA4	142
29.4	1627	3.1	49.0	50000	A703_49.0 S4 M4SA4	150	A703_49.0 P132 BN132SA4	151
32	1502	3.2	45.2	50000	A703_45.2 S4 M4SA4	150	A703_45.2 P132 BN132SA4	151
32	1501	1.9	45.2	30000	A603_45.2 S4 M4SA4	146	A603_45.2 P132 BN132SA4	147
32	1495	1.0	45.0	12400	A503_45.0 S4 M4SA4	138	A503_45.0 P132 BN132SA4	139
35	1385	2.0	41.7	30000	A603_41.7 S4 M4SA4	146	A603_41.7 P132 BN132SA4	147
35	1360	1.1	40.9	12600	A503_40.9 S4 M4SA4	138	A503_40.9 P132 BN132SA4	139
36	1338	1.5	40.3	30000	A553_40.3 S4 M4SA4	142	A553_40.3 P132 BN132SA4	142
40	1182	1.3	35.6	12700	A503_35.6 S4 M4SA4	138	A503_35.6 P132 BN132SA4	139
42	1139	2.5	34.3	30000	A603_34.3 S4 M4SA4	146	A603_34.3 P132 BN132SA4	147
44	1075	1.4	32.4	12700	A503_32.4 S4 M4SA4	138	A503_32.4 P132 BN132SA4	139
45	1051	2.7	31.7	30000	A603_31.7 S4 M4SA4	146	A603_31.7 P132 BN132SA4	147
48	994	2.0	29.9	30000	A553_29.9 S4 M4SA4	142	A553_29.9 P132 BN132SA4	142
52	925	3.0	27.9	30000	A603_27.9 S4 M4SA4	146	A603_27.9 P132 BN132SA4	147
54	878	1.7	26.4	12600	A503_26.4 S4 M4SA4	138	A503_26.4 P132 BN132SA4	139
56	854	3.3	25.7	30000	A603_25.7 S4 M4SA4	146	A603_25.7 P132 BN132SA4	147
60	799	1.9	24.0	12500	A503_24.0 S4 M4SA4	138	A503_24.0 P132 BN132SA4	139
61	790	2.5	23.8	29800	A553_23.8 S4 M4SA4	142	A553_23.8 P132 BN132SA4	142
69	718	1.7	20.9	14400	A502_20.9 S4 M4SA4	138	A502_20.9 P132 BN132SA4	139
70	706	2.8	20.6	30000	A602_20.6 S4 M4SA4	146	A602_20.6 P132 BN132SA4	147
75	660	2.7	19.2	29300	A552_19.2 S4 M4SA4	142	A552_19.2 P132 BN132SA4	142
81	609	1.0	17.8	9280	A412_17.8 S4 M4SA4	134	A412_17.8 P132 BN132SA4	135
86	574	3.5	16.7	30000	A602_16.7 S4 M4SA4	146	A602_16.7 P132 BN132SA4	147
87	568	2.1	16.6	13600	A502_16.6 S4 M4SA4	138	A502_16.6 P132 BN132SA4	139
89	552	1.1	16.1	9160	A412_16.1 S4 M4SA4	134	A412_16.1 P132 BN132SA4	135
92	538	3.3	15.7	27700	A552_15.7 S4 M4SA4	142	A552_15.7 P132 BN132SA4	142
105	472	1.2	13.8	8940	A412_13.8 S4 M4SA4	134	A412_13.8 P132 BN132SA4	135
110	450	2.4	13.1	12800	A502_13.1 S4 M4SA4	138	A502_13.1 P132 BN132SA4	139
122	404	1.0	11.8	6450	A352_11.8 S4 M4SA4	130	A352_11.8 P132 BN132SA4	131
123	403	1.4	11.7	8670	A412_11.7 S4 M4SA4	134	A412_11.7 P132 BN132SA4	135
135	365	1.1	10.6	6360	A352_10.6 S4 M4SA4	130	A352_10.6 P132 BN132SA4	131
142	348	1.5	10.1	8440	A412_10.1 S4 M4SA4	134	A412_10.1 P132 BN132SA4	135
148	334	3.0	9.7	11800	A502_9.7 S4 M4SA4	138	A502_9.7 P132 BN132SA4	139
155	319	1.3	9.3	6240	A352_9.3 S4 M4SA4	130	A352_9.3 P132 BN132SA4	131
157	316	1.7	9.2	8250	A412_9.2 S4 M4SA4	134	A412_9.2 P132 BN132SA4	135
170	290	1.3	8.5	6140	A352_8.5 S4 M4SA4	130	A352_8.5 P132 BN132SA4	131
173	286	1.9	8.3	8080	A412_8.3 S4 M4SA4	134	A412_8.3 P132 BN132SA4	135
202	244	2.3	7.1	7790	A412_7.1 S4 M4SA4	134	A412_7.1 P132 BN132SA4	135
205	241	1.5	7.0	5930	A352_7.0 S4 M4SA4	130	A352_7.0 P132 BN132SA4	131
225	220	1.6	6.4	5820	A352_6.4 S4 M4SA4	130	A352_6.4 P132 BN132SA4	131
246	201	2.7	11.7	7430	A412_11.7 S4 M4SA2	134	A412_11.7 P132 BN132SA2	135
266	186	1.8	5.4	5610	A352_5.4 S4 M4SA4	130	A352_5.4 P132 BN132SA4	131
275	180	3.1	5.2	7230	A412_5.2 S4 M4SA4	134	A412_5.2 P132 BN132SA4	135
285	173	2.5	10.1	7170	A412_10.1 S4 M4SA2	134	A412_10.1 P132 BN132SA2	135
411	120	3.1	7.0	5060	A352_7.0 S4 M4SA2	130	A352_7.0 P132 BN132SA2	131

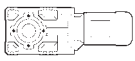



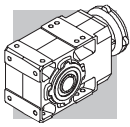

7.5 kW





n ₂ min ⁻¹	M ₂ Nm	S	i	R _{n2} N			 IEC 	
4.0	15759	0.9	355.8	75000	A904_355.8 S4 M4LA4	156	A904_355.8 P132 BN132MA4	157
4.7	13504	1.0	304.9	75000	A904_304.9 S4 M4LA4	156	A904_304.9 P132 BN132MA4	157
5.1	12465	1.1	281.4	75000	A904_281.4 S4 M4LA4	156	A904_281.4 P132 BN132MA4	157
6.4	10029	1.4	226.4	75000	A904_226.4 S4 M4LA4	156	A904_226.4 P132 BN132MA4	157
6.9	9257	1.5	209.0	75000	A904_209.0 S4 M4LA4	156	A904_209.0 P132 BN132MA4	157
8.0	7971	1.8	180.0	75000	A904_180.0 S4 M4LA4	156	A904_180.0 P132 BN132MA4	157
8.4	7587	1.1	171.3	65000	A804_171.3 S4 M4LA4	153	A804_171.3 P132 BN132MA4	154
8.7	7358	1.9	166.1	75000	A904_166.1 S4 M4LA4	156	A904_166.1 P132 BN132MA4	157
9.2	7101	1.1	156.8	65000	A803_156.8 S4 M4LA4	153	A803_156.8 P132 BN132MA4	154
9.5	6839	2.0	151.0	75000	A903_151.0 S4 M4LA4	156	A903_151.0 P132 BN132MA4	157
9.9	6555	1.2	144.7	65000	A803_144.7 S4 M4LA4	153	A803_144.7 P132 BN132MA4	154
10.3	6313	2.0	139.4	75000	A903_139.4 S4 M4LA4	156	A903_139.4 P132 BN132MA4	157
11.4	5735	2.3	126.6	75000	A903_126.6 S4 M4LA4	156	A903_126.6 P132 BN132MA4	157
11.5	5689	1.4	125.6	65000	A803_125.6 S4 M4LA4	153	A803_125.6 P132 BN132MA4	154
11.9	5462	0.9	120.6	50000	A703_120.6 S4 M4LA4	150	A703_120.6 P132 BN132MA4	151
12.3	5294	2.6	116.9	75000	A903_116.9 S4 M4LA4	156	A903_116.9 P132 BN132MA4	157
12.4	5251	1.5	116.0	65000	A803_116.0 S4 M4LA4	153	A803_116.0 P132 BN132MA4	154
13.5	4838	2.9	106.8	75000	A903_106.8 S4 M4LA4	156	A903_106.8 P132 BN132MA4	157
13.8	4721	1.1	104.2	50000	A703_104.2 S4 M4LA4	150	A703_104.2 P132 BN132MA4	151
13.8	4711	1.7	104.0	65000	A803_104.0 S4 M4LA4	153	A803_104.0 P132 BN132MA4	154
14.6	4465	3.1	98.6	75000	A903_98.6 S4 M4LA4	156	A903_98.6 P132 BN132MA4	157
15.0	4357	1.1	96.2	50000	A703_96.2 S4 M4LA4	150	A703_96.2 P132 BN132MA4	151
15.0	4349	1.8	96.0	65000	A803_96.0 S4 M4LA4	153	A803_96.0 P132 BN132MA4	154
16.1	4039	2.0	89.2	65000	A803_89.2 S4 M4LA4	153	A803_89.2 P132 BN132MA4	154
16.8	3892	1.3	85.9	50000	A703_85.9 S4 M4LA4	150	A703_85.9 P132 BN132MA4	151
17.5	3728	2.1	82.3	65000	A803_82.3 S4 M4LA4	153	A803_82.3 P132 BN132MA4	154
18.2	3593	1.4	79.3	50000	A703_79.3 S4 M4LA4	150	A703_79.3 P132 BN132MA4	151
19.9	3284	1.5	72.5	50000	A703_72.5 S4 M4LA4	150	A703_72.5 P132 BN132MA4	151
19.9	3277	2.4	72.4	65000	A803_72.4 S4 M4LA4	153	A803_72.4 P132 BN132MA4	154
20.5	3188	0.9	70.4	30000	A603_70.4 S4 M4LA4	146	A603_70.4 P132 BN132MA4	147
21.5	3032	1.6	66.9	50000	A703_66.9 S4 M4LA4	150	A703_66.9 P132 BN132MA4	151
21.6	3025	2.6	66.8	65000	A803_66.8 S4 M4LA4	153	A803_66.8 P132 BN132MA4	154
22.2	2943	1.0	65.0	30000	A603_65.0 S4 M4LA4	146	A603_65.0 P132 BN132MA4	147
24.1	2707	3.0	59.8	63800	A803_59.8 S4 M4LA4	153	A803_59.8 P132 BN132MA4	154
25.0	2612	1.9	57.7	50000	A703_57.7 S4 M4LA4	150	A703_57.7 P132 BN132MA4	151
25.9	2518	1.1	55.6	30000	A603_55.6 S4 M4LA4	146	A603_55.6 P132 BN132MA4	147
26.1	2499	3.2	55.2	62600	A803_55.2 S4 M4LA4	153	A803_55.2 P132 BN132MA4	154
27.1	2411	2.1	53.2	50000	A703_53.2 S4 M4LA4	150	A703_53.2 P132 BN132MA4	151
28.1	2324	1.2	51.3	30000	A603_51.3 S4 M4LA4	146	A603_51.3 P132 BN132MA4	147
29.4	2219	2.3	49.0	50000	A703_49.0 S4 M4LA4	150	A703_49.0 P132 BN132MA4	151
32	2048	2.3	45.2	50000	A703_45.2 S4 M4LA4	150	A703_45.2 P132 BN132MA4	151
32	2046	1.4	45.2	30000	A603_45.2 S4 M4LA4	146	A603_45.2 P132 BN132MA4	147
35	1889	1.5	41.7	30000	A603_41.7 S4 M4LA4	146	A603_41.7 P132 BN132MA4	147
36	1825	1.1	40.3	30000	A553_40.3 S4 M4LA4	142	A553_40.3 P132 BN132MA4	142
38	1738	2.8	38.4	50000	A703_38.4 S4 M4LA4	150	A703_38.4 P132 BN132MA4	151
40	1612	0.9	35.6	10100	A503_35.6 S4 M4LA4	138	A503_35.6 P132 BN132MA4	139
41	1605	2.8	35.4	50000	A703_35.4 S4 M4LA4	150	A703_35.4 P132 BN132MA4	151
42	1553	1.8	34.3	30000	A603_34.3 S4 M4LA4	146	A603_34.3 P132 BN132MA4	147
44	1466	1.0	32.4	10300	A503_32.4 S4 M4LA4	138	A503_32.4 P132 BN132MA4	139
45	1434	2.0	31.7	30000	A603_31.7 S4 M4LA4	146	A603_31.7 P132 BN132MA4	147
48	1355	1.5	29.9	30000	A553_29.9 S4 M4LA4	142	A553_29.9 P132 BN132MA4	142
52	1261	2.2	27.9	30000	A603_27.9 S4 M4LA4	146	A603_27.9 P132 BN132MA4	147
54	1197	1.3	26.4	10700	A503_26.4 S4 M4LA4	138	A503_26.4 P132 BN132MA4	139
56	1164	2.4	25.7	30000	A603_25.7 S4 M4LA4	146	A603_25.7 P132 BN132MA4	147
60	1089	1.4	24.0	10800	A503_24.0 S4 M4LA4	138	A503_24.0 P132 BN132MA4	139
61	1077	1.8	23.8	28800	A553_23.8 S4 M4LA4	142	A553_23.8 P132 BN132MA4	142
69	979	1.2	20.9	13700	A502_20.9 S4 M4LA4	138	A502_20.9 P132 BN132MA4	139
70	963	2.1	20.6	30000	A602_20.6 S4 M4LA4	146	A602_20.6 P132 BN132MA4	147
75	900	2.0	19.2	28800	A552_19.2 S4 M4LA4	142	A552_19.2 P132 BN132MA4	142
86	783	2.6	16.7	30000	A602_16.7 S4 M4LA4	146	A602_16.7 P132 BN132MA4	147
87	775	1.5	16.6	13000	A502_16.6 S4 M4LA4	138	A502_16.6 P132 BN132MA4	139
92	734	2.5	15.7	27300	A552_15.7 S4 M4LA4	142	A552_15.7 P132 BN132MA4	142
105	644	0.9	13.8	8130	A412_13.8 S4 M4LA4	134	A412_13.8 P132 BN132MA4	135
110	613	1.8	13.1	12300	A502_13.1 S4 M4LA4	138	A502_13.1 P132 BN132MA4	139
110	612	2.9	13.1	26100	A552_13.1 S4 M4LA4	142	A552_13.1 P132 BN132MA4	142
113	594	3.4	12.7	30000	A602_12.7 S4 M4LA4	146	A602_12.7 P132 BN132MA4	147



7.5 kW



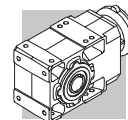

n₂ min ⁻¹	M₂ Nm	S	i	R_{n2} N			 IEC 	
123	549	1.0	11.7	7970	A412_11.7 S4 M4LA4	134	A412_11.7 P132 BN132MA4	135
142	474	1.1	10.1	7850	A412_10.1 S4 M4LA4	134	A412_10.1 P132 BN132MA4	135
148	455	2.2	9.7	11500	A502_9.7 S4 M4LA4	138	A502_9.7 P132 BN132MA4	139
155	436	0.9	9.3	5650	A352_9.3 S4 M4LA4	130	A352_9.3 P132 BN132MA4	131
157	430	1.3	9.2	7710	A412_9.2 S4 M4LA4	134	A412_9.2 P132 BN132MA4	135
170	396	1.0	8.5	5600	A352_8.5 S4 M4LA4	130	A352_8.5 P132 BN132MA4	131
173	390	1.4	8.3	7590	A412_8.3 S4 M4LA4	134	A412_8.3 P132 BN132MA4	135
186	362	2.6	7.7	10800	A502_7.7 S4 M4LA4	138	A502_7.7 P132 BN132MA4	139
202	333	1.7	7.1	7370	A412_7.1 S4 M4LA4	134	A412_7.1 P132 BN132MA4	135
205	329	1.1	7.0	5490	A352_7.0 S4 M4LA4	130	A352_7.0 P132 BN132MA4	131
225	300	1.2	6.4	5420	A352_6.4 S4 M4LA4	130	A352_6.4 P132 BN132MA4	131
266	253	1.3	5.4	5270	A352_5.4 S4 M4LA4	130	A352_5.4 P132 BN132MA4	131
275	245	2.2	5.2	6920	A412_5.2 S4 M4LA4	134	A412_5.2 P132 BN132MA4	135
315	214	2.5	9.2	6710	A412_9.2 S4 M4SB2	134	A412_9.2 P132 BN132SB2	135
348	194	2.6	8.3	6550	A412_8.3 S4 M4SB2	134	A412_8.3 P132 BN132SB2	135
413	163	2.3	7.0	4830	A352_7.0 S4 M4SB2	130	A352_7.0 P132 BN132SB2	131
536	126	2.7	5.4	4550	A352_5.4 S4 M4SB2	130	A352_5.4 P132 BN132SB2	131

9.2 kW





n₂ min ⁻¹	M₂ Nm	S	i	R_{n2} N			 IEC 	
5.1	15291	0.9	281.4	75000	A904_281.4 S4 M4LB4	156	A904_281.4 P132 BN132MB4	157
6.4	12302	1.1	226.4	75000	A904_226.4 S4 M4LB4	156	A904_226.4 P132 BN132MB4	157
6.9	11356	1.2	209.0	75000	A904_209.0 S4 M4LB4	156	A904_209.0 P132 BN132MB4	157
8.0	9778	1.4	180.0	75000	A904_180.0 S4 M4LB4	156	A904_180.0 P132 BN132MB4	157
8.4	9307	0.9	171.3	65000	A804_171.3 S4 M4LB4	153	A804_171.3 P132 BN132MB4	154
8.7	9026	1.6	166.1	75000	A904_166.1 S4 M4LB4	156	A904_166.1 P132 BN132MB4	157
9.2	8711	0.9	156.8	65000	A803_156.8 S4 M4LB4	153	A803_156.8 P132 BN132MB4	154
9.5	8389	1.6	151.0	75000	A903_151.0 S4 M4LB4	156	A903_151.0 P132 BN132MB4	157
9.9	8040	1.0	144.7	65000	A803_144.7 S4 M4LB4	153	A803_144.7 P132 BN132MB4	154
10.3	7744	1.6	139.4	75000	A903_139.4 S4 M4LB4	156	A903_139.4 P132 BN132MB4	157
11.4	7035	1.9	126.6	75000	A903_126.6 S4 M4LB4	156	A903_126.6 P132 BN132MB4	157
11.5	6978	1.1	125.6	65000	A803_125.6 S4 M4LB4	153	A803_125.6 P132 BN132MB4	154
12.3	6494	2.2	116.9	75000	A903_116.9 S4 M4LB4	156	A903_116.9 P132 BN132MB4	157
12.4	6442	1.2	116.0	65000	A803_116.0 S4 M4LB4	153	A803_116.0 P132 BN132MB4	154
13.5	5934	2.4	106.8	75000	A903_106.8 S4 M4LB4	156	A903_106.8 P132 BN132MB4	157
13.8	5779	1.4	104.0	65000	A803_104.0 S4 M4LB4	153	A803_104.0 P132 BN132MB4	154
14.6	5478	2.6	98.6	75000	A903_98.6 S4 M4LB4	156	A903_98.6 P132 BN132MB4	157
15.0	5345	0.9	96.2	50000	A703_96.2 S4 M4LB4	150	A703_96.2 P132 BN132MB4	151
15.0	5335	1.5	96.0	65000	A803_96.0 S4 M4LB4	153	A803_96.0 P132 BN132MB4	154
16.1	4954	1.6	89.2	65000	A803_89.2 S4 M4LB4	153	A803_89.2 P132 BN132MB4	154
16.5	4837	2.9	87.1	75000	A903_87.1 S4 M4LB4	156	A903_87.1 P132 BN132MB4	157
16.8	4774	1.0	85.9	50000	A703_85.9 S4 M4LB4	150	A703_85.9 P132 BN132MB4	151
17.5	4573	1.7	82.3	65000	A803_82.3 S4 M4LB4	153	A803_82.3 P132 BN132MB4	154
17.9	4465	3.1	80.4	75000	A903_80.4 S4 M4LB4	156	A903_80.4 P132 BN132MB4	157
18.2	4407	1.1	79.3	50000	A703_79.3 S4 M4LB4	150	A703_79.3 P132 BN132MB4	151
19.3	4137	3.4	74.5	75000	A903_74.5 S4 M4LB4	156	A903_74.5 P132 BN132MB4	157
19.9	4029	1.2	72.5	50000	A703_72.5 S4 M4LB4	150	A703_72.5 P132 BN132MB4	151
19.9	4020	2.0	72.4	65000	A803_72.4 S4 M4LB4	153	A803_72.4 P132 BN132MB4	154
21.5	3719	1.3	66.9	50000	A703_66.9 S4 M4LB4	150	A703_66.9 P132 BN132MB4	151
21.6	3711	2.2	66.8	63800	A803_66.8 S4 M4LB4	153	A803_66.8 P132 BN132MB4	154
24.1	3321	2.4	59.8	62400	A803_59.8 S4 M4LB4	153	A803_59.8 P132 BN132MB4	154
25.0	3204	1.6	57.7	50000	A703_57.7 S4 M4LB4	150	A703_57.7 P132 BN132MB4	151
25.9	3089	0.9	55.6	30000	A603_55.6 S4 M4LB4	146	A603_55.6 P132 BN132MB4	147
26.1	3065	2.6	55.2	61300	A803_55.2 S4 M4LB4	153	A803_55.2 P132 BN132MB4	154
27.1	2957	1.7	53.2	50000	A703_53.2 S4 M4LB4	150	A703_53.2 P132 BN132MB4	151
28.1	2851	1.0	51.3	30000	A603_51.3 S4 M4LB4	146	A603_51.3 P132 BN132MB4	147
29.4	2722	1.8	49.0	50000	A703_49.0 S4 M4LB4	150	A703_49.0 P132 BN132MB4	151
30	2677	3.0	48.2	59500	A803_48.2 S4 M4LB4	153	A803_48.2 P132 BN132MB4	154
32	2513	1.9	45.2	50000	A703_45.2 S4 M4LB4	150	A703_45.2 P132 BN132MB4	151
32	2510	1.1	45.2	30000	A603_45.2 S4 M4LB4	146	A603_45.2 P132 BN132MB4	147
32	2471	3.0	44.5	58400	A803_44.5 S4 M4LB4	153	A803_44.5 P132 BN132MB4	154



9.2 kW

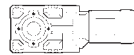

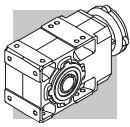

n₂ min ⁻¹	M₂ Nm	S	i	R_{n2} N				
35	2317	1.2	41.7	30000	A603_41.7 S4 M4LB4	146	A603_41.7 P132 BN132MB4	147
38	2132	2.3	38.4	50000	A703_38.4 S4 M4LB4	150	A703_38.4 P132 BN132MB4	151
41	1968	2.3	35.4	50000	A703_35.4 S4 M4LB4	150	A703_35.4 P132 BN132MB4	151
42	1905	1.5	34.3	30000	A603_34.3 S4 M4LB4	146	A603_34.3 P132 BN132MB4	147
45	1759	1.6	31.7	30000	A603_31.7 S4 M4LB4	146	A603_31.7 P132 BN132MB4	147
48	1663	1.2	29.9	29100	A553_29.9 S4 M4LB4	142	A553_29.9 P132 BN132MB4	142
52	1547	1.8	27.9	30000	A603_27.9 S4 M4LB4	146	A603_27.9 P132 BN132MB4	147
54	1469	1.0	26.4	9130	A503_26.4 S4 M4LB4	138	A503_26.4 P132 BN132MB4	139
56	1428	2.0	25.7	30000	A603_25.7 S4 M4LB4	146	A603_25.7 P132 BN132MB4	147
60	1336	1.1	24.0	9370	A503_24.0 S4 M4LB4	138	A503_24.0 P132 BN132MB4	139
61	1322	1.5	23.8	27900	A553_23.8 S4 M4LB4	142	A553_23.8 P132 BN132MB4	142
68	1183	3.4	21.3	46000	A703_21.3 S4 M4LB4	150	A703_21.3 P132 BN132MB4	151
69	1200	1.0	20.9	13000	A502_20.9 S4 M4LB4	138	A502_20.9 P132 BN132MB4	139
70	1182	1.7	20.6	30000	A602_20.6 S4 M4LB4	146	A602_20.6 P132 BN132MB4	147
73	1092	3.4	19.7	45100	A703_19.7 S4 M4LB4	150	A703_19.7 P132 BN132MB4	151
75	1104	1.6	19.2	28400	A552_19.2 S4 M4LB4	142	A552_19.2 P132 BN132MB4	142
86	960	2.1	16.7	30000	A602_16.7 S4 M4LB4	146	A602_16.7 P132 BN132MB4	147
87	951	1.3	16.6	12500	A502_16.6 S4 M4LB4	138	A502_16.6 P132 BN132MB4	139
92	900	2.0	15.7	27000	A552_15.7 S4 M4LB4	142	A552_15.7 P132 BN132MB4	142
110	752	1.5	13.1	11900	A502_13.1 S4 M4LB4	138	A502_13.1 P132 BN132MB4	139
110	750	2.4	13.1	25800	A552_13.1 S4 M4LB4	142	A552_13.1 P132 BN132MB4	142
113	729	2.7	12.7	30000	A602_12.7 S4 M4LB4	146	A602_12.7 P132 BN132MB4	147
123	650	2.5	23.8	24100	A553_23.8 S4 M4LA2	142	A553_23.8 P132 BN132M2	142
139	594	3.0	10.4	24200	A552_10.4 S4 M4LB4	142	A552_10.4 P132 BN132MB4	142
140	592	3.4	10.3	30000	A602_10.3 S4 M4LB4	146	A602_10.3 P132 BN132MB4	147
142	581	0.9	10.1	7340	A412_10.1 S4 M4LB4	134	A412_10.1 P132 BN132MB4	135
148	559	1.8	9.7	11200	A502_9.7 S4 M4LB4	138	A502_9.7 P132 BN132MB4	139
157	528	1.0	9.2	7250	A412_9.2 S4 M4LB4	134	A412_9.2 P132 BN132MB4	135
173	478	1.2	8.3	7170	A412_8.3 S4 M4LB4	134	A412_8.3 P132 BN132MB4	135
186	444	2.1	7.7	10600	A502_7.7 S4 M4LB4	138	A502_7.7 P132 BN132MB4	139
202	409	1.3	7.1	7020	A412_7.1 S4 M4LB4	134	A412_7.1 P132 BN132MB4	135
205	403	0.9	7.0	5110	A352_7.0 S4 M4LB4	130	A352_7.0 P132 BN132MB4	131
225	368	1.0	6.4	5070	A352_6.4 S4 M4LB4	130	A352_6.4 P132 BN132MB4	131
266	311	1.1	5.4	4980	A352_5.4 S4 M4LB4	130	A352_5.4 P132 BN132MB4	131
275	301	1.8	5.2	6660	A412_5.2 S4 M4LB4	134	A412_5.2 P132 BN132MB4	135
319	259	2.0	9.2	6480	A412_9.2 S4 M4LA2	134	A412_9.2 P132 BN132M2	135
379	218	3.4	7.7	8780	A502_7.7 S4 M4LA2	138	A502_7.7 P132 BN132M2	139
541	153	2.2	5.4	4410	A352_5.4 S4 M4LA2	130	A352_5.4 P132 BN132M2	131
559	148	3.0	5.2	5690	A412_5.2 S4 M4LA2	134	A412_5.2 P132 BN132M2	135

11 kW





n₂ min ⁻¹	M₂ Nm	S	i	R_{n2} N				
6.4	14709	1.0	226.4	75000	A904_226.4 S4 M4LC4	156	A904_226.4 P160 BN160MR4	157
6.9	13577	1.0	209.0	75000	A904_209.0 S4 M4LC4	156	A904_209.0 P160 BN160MR4	157
8.0	11691	1.2	180.0	75000	A904_180.0 S4 M4LC4	156	A904_180.0 P160 BN160MR4	157
8.7	10792	1.3	166.1	75000	A904_166.1 S4 M4LC4	156	A904_166.1 P160 BN160MR4	157
9.5	10030	1.4	151.0	75000	A903_151.0 S4 M4LC4	156	A903_151.0 P160 BN160MR4	157
10.3	9259	1.4	139.4	75000	A903_139.4 S4 M4LC4	156	A903_139.4 P160 BN160MR4	157
11.4	8412	1.6	126.6	75000	A903_126.6 S4 M4LC4	156	A903_126.6 P160 BN160MR4	157
11.5	8344	1.0	125.6	65000	A803_125.6 S4 M4LC4	153	A803_125.6 P160 BN160MR4	154
12.3	7765	1.8	116.9	75000	A903_116.9 S4 M4LC4	156	A903_116.9 P160 BN160MR4	157
12.4	7702	1.0	116.0	65000	A803_116.0 S4 M4LC4	153	A803_116.0 P160 BN160MR4	154
13.5	7095	2.0	106.8	75000	A903_106.8 S4 M4LC4	156	A903_106.8 P160 BN160MR4	157
13.8	6910	1.2	104.0	65000	A803_104.0 S4 M4LC4	153	A803_104.0 P160 BN160MR4	154
14.6	6549	2.1	98.6	75000	A903_98.6 S4 M4LC4	156	A903_98.6 P160 BN160MR4	157
15.0	6378	1.3	96.0	65000	A803_96.0 S4 M4LC4	153	A803_96.0 P160 BN160MR4	154
16.1	5923	1.4	89.2	65000	A803_89.2 S4 M4LC4	153	A803_89.2 P160 BN160MR4	154
16.5	5783	2.4	87.1	75000	A903_87.1 S4 M4LC4	156	A903_87.1 P160 BN160MR4	157
17.5	5468	1.5	82.3	64500	A803_82.3 S4 M4LC4	153	A803_82.3 P160 BN160MR4	154
17.9	5338	2.6	80.4	75000	A903_80.4 S4 M4LC4	156	A903_80.4 P160 BN160MR4	157
18.2	5269	0.9	79.3	50000	A703_79.3 S4 M4LC4	150	A703_79.3 P160 BN160MR4	151
19.3	4947	2.8	74.5	75000	A903_74.5 S4 M4LC4	156	A903_74.5 P160 BN160MR4	157



11 kW



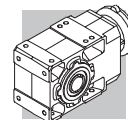

n₂ min ⁻¹	M₂ Nm	S	i	R_{n2} N			 IEC 	
19.9	4817	1.0	72.5	50000	A703_72.5 S4 M4LC4	150	A703_72.5 P160 BN160MR4	151
19.9	4807	1.7	72.4	63200	A803_72.4 S4 M4LC4	153	A803_72.4 P160 BN160MR4	154
20.9	4566	3.1	68.8	75000	A903_68.8 S4 M4LC4	156	A903_68.8 P160 BN160MR4	157
21.5	4446	1.1	66.9	50000	A703_66.9 S4 M4LC4	150	A703_66.9 P160 BN160MR4	151
21.6	4437	1.8	66.8	62200	A803_66.8 S4 M4LC4	153	A803_66.8 P160 BN160MR4	154
24.1	3971	2.0	59.8	60900	A803_59.8 S4 M4LC4	153	A803_59.8 P160 BN160MR4	154
24.2	3960	3.5	59.6	75000	A903_59.6 S4 M4LC4	156	A903_59.6 P160 BN160MR4	157
25.0	3830	1.3	57.7	50000	A703_57.7 S4 M4LC4	150	A703_57.7 P160 BN160MR4	151
26.1	3665	2.2	55.2	59900	A803_55.2 S4 M4LC4	153	A803_55.2 P160 BN160MR4	154
27.1	3536	1.4	53.2	50000	A703_53.2 S4 M4LC4	150	A703_53.2 P160 BN160MR4	151
29.4	3255	1.5	49.0	50000	A703_49.0 S4 M4LC4	150	A703_49.0 P160 BN160MR4	151
30	3200	2.5	48.2	58300	A803_48.2 S4 M4LC4	153	A803_48.2 P160 BN160MR4	154
32	3004	1.6	45.2	50000	A703_45.2 S4 M4LC4	150	A703_45.2 P160 BN160MR4	151
32	3001	0.9	45.2	30000	A603_45.2 S4 M4LC4	146	A603_45.2 P160 BN160MR4	147
32	2954	2.5	44.5	57300	A803_44.5 S4 M4LC4	153	A803_44.5 P160 BN160MR4	154
35	2771	1.0	41.7	30000	A603_41.7 S4 M4LC4	146	A603_41.7 P160 BN160MR4	147
37	2557	3.0	38.5	55500	A803_38.5 P160 BN160MR4	156	A803_38.5 P160 BN160MR4	157
38	2549	1.9	38.4	50000	A703_38.4 S4 M4LC4	150	A703_38.4 P160 BN160MR4	151
41	2360	3.0	35.5	54500	A803_35.5 P160 BN160MR4	156	A803_35.5 P160 BN160MR4	157
41	2353	1.9	35.4	50000	A703_35.4 S4 M4LC4	150	A703_35.4 P160 BN160MR4	151
42	2278	1.2	34.3	30000	A603_34.3 S4 M4LC4	146	A603_34.3 P160 BN160MR4	147
45	2103	1.3	31.7	30000	A603_31.7 S4 M4LC4	146	A603_31.7 P160 BN160MR4	147
47	2031	3.2	30.6	52600	A803_30.6 P160 BN160MR4	156	A803_30.6 P160 BN160MR4	157
48	1999	2.3	30.1	49400	A703_30.1 P160 BN160MR4	150	A703_30.1 P160 BN160MR4	151
51	1875	3.5	28.2	51600	A803_28.2 P160 BN160MR4	156	A803_28.2 P160 BN160MR4	157
52	1850	1.5	27.9	30000	A603_27.9 S4 M4LC4	146	A603_27.9 P160 BN160MR4	147
52	1845	2.3	27.8	48500	A703_27.8 P160 BN160MR4	150	A703_27.8 P160 BN160MR4	151
56	1708	1.6	25.7	30000	A603_25.7 S4 M4LC4	146	A603_25.7 P160 BN160MR4	147
60	1597	0.9	24.0	7800	A503_24.0 P160 BN160MR4	138	A503_24.0 P160 BN160MR4	139
61	1562	2.8	23.5	46600	A703_23.5 P160 BN160MR4	150	A703_23.5 P160 BN160MR4	151
68	1415	2.8	21.3	45500	A703_21.3 S4 M4LC4	150	A703_21.3 P160 BN160MR4	151
70	1413	1.4	20.6	30000	A602_20.6 S4 M4LC4	146	A602_20.6 P160 BN160MR4	147
73	1306	2.8	19.7	44500	A703_19.7 S4 M4LC4	150	A703_19.7 P160 BN160MR4	151
75	1319	1.4	19.2	27900	A552_19.2 S4 M4LC4	142	A552_19.2 P160 BN160MR4	142
86	1148	1.7	16.7	30000	A602_16.7 S4 M4LC4	146	A602_16.7 P160 BN160MR4	147
87	1137	1.1	16.6	12000	A502_16.6 S4 M4LC4	138	A502_16.6 P160 BN160MR4	139
92	1076	1.7	15.7	26600	A552_15.7 S4 M4LC4	142	A552_15.7 P160 BN160MR4	142
110	899	1.2	13.1	11500	A502_13.1 S4 M4LC4	138	A502_13.1 P160 BN160MR4	139
110	897	2.0	13.1	25400	A552_13.1 S4 M4LC4	142	A552_13.1 P160 BN160MR4	142
113	872	2.3	12.7	30000	A602_12.7 S4 M4LC4	146	A602_12.7 P160 BN160MR4	147
123	779	2.1	23.8	23600	A553_23.8 S4 M4LC2	142	A553_23.8 P160 BN160MR2	142
139	710	2.5	10.4	24000	A552_10.4 S4 M4LC4	142	A552_10.4 P160 BN160MR4	142
140	708	2.8	10.3	30000	A602_10.3 S4 M4LC4	146	A602_10.3 P160 BN160MR4	147
148	668	1.5	9.7	10800	A502_9.7 S4 M4LC4	138	A502_9.7 P160 BN160MR4	139
170	581	3.1	8.5	22800	A552_8.5 S4 M4LC4	142	A552_8.5 P160 BN160MR4	142
186	531	1.8	7.7	10300	A502_7.7 S4 M4LC4	138	A502_7.7 P160 BN160MR4	139
202	489	1.1	7.1	6640	A412_7.1 S4 M4LC4	134		
223	443	2.0	13.1	9920	A502_13.1 S4 M4LC2	138	A502_13.1 P160 BN160MR2	139
248	399	1.0	11.8	4690	A352_11.8 S4 M4LC2	130		
275	360	1.1	10.6	4660	A352_10.6 S4 M4LC2	130		
317	311	1.7	9.2	6230	A412_9.2 S4 M4LC2	134		
377	262	2.8	7.7	8650	A502_7.7 S4 M4LC2	138	A502_7.7 P160 BN160MR2	139
416	238	1.6	7.0	4440	A352_7.0 S4 M4LC2	130		
456	217	1.6	6.4	4380	A352_6.4 S4 M4LC2	130		
539	183	1.9	5.4	4250	A352_5.4 S4 M4LC2	130		

15 kW

n₂ min ⁻¹	M₂ Nm	S	i	R_{n2} N			 IEC 	
8.1	15724	0.9	180.0	75000			A904_180.0 P160 BN160L4	157
8.8	14514	1.0	166.1	75000			A904_166.1 P160 BN160L4	157
9.7	13490	1.0	151.0	75000	A903_151.0 S5 M5SB4	156	A903_151.0 P160 BN160L4	157
10.5	12452	1.0	139.4	75000	A903_139.4 S5 M5SB4	156	A903_139.4 P160 BN160L4	157
11.5	11314	1.2	126.6	75000	A903_126.6 S5 M5SB4	156	A903_126.6 P160 BN160L4	157
12.5	10443	1.3	116.9	75000	A903_116.9 S5 M5SB4	156	A903_116.9 P160 BN160L4	157





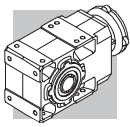

15 kW





n₂ min ⁻¹	M₂ Nm	S	i	R_{n2} N				
13.7	9543	1.5	106.8	75000	A903_106.8 S5 M5SB4	156	A903_106.8 P160 BN160L4	157
14.8	8808	1.6	98.6	75000	A903_98.6 S5 M5SB4	156	A903_98.6 P160 BN160L4	157
15.2	8578	0.9	96.0	60600	A803_96.0 S5 M5SB4	153	A803_96.0 P160 BN160L4	154
16.4	7967	1.0	89.2	60400	A803_89.2 S5 M5SB4	153	A803_89.2 P160 BN160L4	154
16.8	7778	1.8	87.1	75000	A903_87.1 S5 M5SB4	156	A903_87.1 P160 BN160L4	157
17.7	7354	1.1	82.3	59800	A803_82.3 S5 M5SB4	153	A803_82.3 P160 BN160L4	154
18.2	7180	1.9	80.4	75000	A903_80.4 S5 M5SB4	156	A903_80.4 P160 BN160L4	157
19.6	6654	2.1	74.5	75000	A903_74.5 S5 M5SB4	156	A903_74.5 P160 BN160L4	157
20.2	6465	1.2	72.4	59100	A803_72.4 S5 M5SB4	153	A803_72.4 P160 BN160L4	154
21.2	6142	2.3	68.8	75000	A903_68.8 S5 M5SB4	156	A903_68.8 P160 BN160L4	157
21.9	5968	1.3	66.8	58300	A803_66.8 S5 M5SB4	153	A803_66.8 P160 BN160L4	154
24.4	5340	1.5	59.8	57500	A803_59.8 S5 M5SB4	153	A803_59.8 P160 BN160L4	154
24.5	5326	2.6	59.6	75000	A903_59.6 S5 M5SB4	156	A903_59.6 P160 BN160L4	157
25.3	5152	1.0	57.7	50000	A703_57.7 S5 M5SB4	150	A703_57.7 P160 BN160L4	151
26.5	4930	1.6	55.2	56700	A803_55.2 S5 M5SB4	153	A803_55.2 P160 BN160L4	154
26.5	4916	2.8	55.0	75000	A903_55.0 S5 M5SB4	156	A903_55.0 P160 BN160L4	157
27.4	4755	1.1	53.2	50000	A703_53.2 S5 M5SB4	150	A703_53.2 P160 BN160L4	151
29.8	4377	1.1	49.0	50000	A703_49.0 S5 M5SB4	150	A703_49.0 P160 BN160L4	151
30	4315	3.2	48.3	74900			A903_48.3 P160 BN160L4	157
30	4304	1.9	48.2	55500	A803_48.2 S5 M5SB4	153	A803_48.2 P160 BN160L4	154
32	4041	1.2	45.2	50000	A703_45.2 S5 M5SB4	150	A703_45.2 P160 BN160L4	151
33	3983	3.5	44.6	73500			A903_44.6 P160 BN160L4	157
33	3973	1.9	44.5	54700	A803_44.5 S5 M5SB4	153	A803_44.5 P160 BN160L4	154
38	3439	2.2	38.5	53200			A803_38.5 P160 BN160L4	154
38	3429	1.4	38.4	49900	A703_38.4 S5 M5SB4	150	A703_38.4 P160 BN160L4	151
41	3175	2.2	35.5	52300			A803_35.5 P160 BN160L4	154
41	3165	1.4	35.4	49100	A703_35.4 S5 M5SB4	150	A703_35.4 P160 BN160L4	151
43	3064	0.9	34.3	30000	A603_34.3 S5 M5SB4	146	A603_34.3 P160 BN160L4	147
46	2828	1.0	31.7	30000	A603_31.7 S5 M5SB4	146	A603_31.7 P160 BN160L4	147
48	2731	2.4	30.6	50800			A803_30.6 P160 BN160L4	154
49	2689	1.7	30.1	47600			A703_30.1 P160 BN160L4	151
52	2521	2.6	28.2	49900			A803_28.2 P160 BN160L4	154
52	2488	1.1	27.9	30000	A603_27.9 S5 M5SB4	146	A603_27.9 P160 BN160L4	147
53	2482	1.7	27.8	46700			A703_27.8 P160 BN160L4	151
57	2297	1.2	25.7	30000	A603_25.7 S5 M5SB4	146	A603_25.7 P160 BN160L4	147
61	2125	0.9	23.8	25000	A553_23.8 S5 M5SB4	142	A553_23.8 P160 BN160L4	142
62	2101	2.0	23.5	45100	A703_23.5 S5 M5SB4	150	A703_23.5 P160 BN160L4	151
69	1903	2.1	21.3	44100	A703_21.3 S5 M5SB4	150	A703_21.3 P160 BN160L4	151
70	1871	3.5	20.9	46600	A803_20.9 S5 M5SB4	153	A803_20.9 P160 BN160L4	154
71	1900	1.1	20.6	30000	A602_20.6 S5 M5SB4	146	A602_20.6 P160 BN160L4	147
74	1757	2.1	19.7	43300	A703_19.7 S5 M5SB4	150	A703_19.7 P160 BN160L4	151
75	1728	3.5	19.3	45700	A803_19.3 S5 M5SB4	153	A803_19.3 P160 BN160L4	154
76	1775	1.0	19.2	26800	A552_19.2 S5 M5SB4	142	A552_19.2 P160 BN160L4	142
87	1544	1.3	16.7	30000	A602_16.7 S5 M5SB4	146	A602_16.7 P160 BN160L4	147
87	1491	2.7	16.7	41600	A703_16.7 S5 M5SB4	150	A703_16.7 P160 BN160L4	151
93	1447	1.2	15.7	25700	A552_15.7 S5 M5SB4	142	A552_15.7 P160 BN160L4	142
95	1376	2.7	15.4	40800	A703_15.4 S5 M5SB4	150	A703_15.4 P160 BN160L4	151
111	1209	0.9	13.1	10500			A502_13.1 P160 BN160L4	139
112	1207	1.5	13.1	24700	A552_13.1 S5 M5SB4	142	A552_13.1 P160 BN160L4	142
112	1169	3.3	13.1	39200	A703_13.1 S5 M5SB4	150	A703_13.1 P160 BN160L4	151
115	1172	1.7	12.7	30000	A602_12.7 S5 M5SB4	146	A602_12.7 P160 BN160L4	147
121	1079	3.3	12.1	38400	A703_12.1 S5 M5SB4	150	A703_12.1 P160 BN160L4	151
123	1059	1.5	23.8	22600	A553_23.8 S5 M5SB4	142	A553_23.8 P160 BN160L4	142
141	956	1.9	10.4	23400	A552_10.4 S5 M5SB4	142	A552_10.4 P160 BN160L4	142
142	952	2.1	10.3	30000	A602_10.3 S5 M5SB4	146	A602_10.3 P160 BN160L4	147
150	898	1.1	9.7	10100			A502_9.7 P160 BN160L4	139
173	781	2.3	8.5	22200	A552_8.5 S5 M5SB4	142	A552_8.5 P160 BN160L4	142
186	726	2.8	7.9	28300	A602_7.9 S5 M5SB4	146	A602_7.9 P160 BN160L4	147
189	714	1.3	7.7	9750		138	A502_7.7 P160 BN160L4	139
228	592	2.9	6.4	20700	A552_6.4 S5 M5SB4	142	A552_6.4 P160 BN160L4	142
295	456	3.5	4.9	19400	A552_4.9 S5 M5SB4	142	A552_4.9 P160 BN160L4	142
301	448	1.8	9.7	8830			A502_9.7 P160 BN160MB2	139
352	383	1.3	8.3	5630			A412_8.3 P160 BN160MB2	135
379	356	2.1	7.7	8350			A502_7.7 P160 BN160MB2	139



18.5 kW



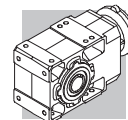

n ₂ min ⁻¹	M ₂ Nm	S	i	R _{n2} N				
11.5	13954	0.9	126.6	75000	A903_126.6 S5 M5LA4	156	A903_126.6 P180 BN180M4	157
12.5	12880	1.1	116.9	75000	A903_116.9 S5 M5LA4	156	A903_116.9 P180 BN180M4	157
13.7	11769	1.2	106.8	75000	A903_106.8 S5 M5LA4	156	A903_106.8 P180 BN180M4	157
14.8	10864	1.3	98.6	75000	A903_98.6 S5 M5LA4	156	A903_98.6 P180 BN180M4	157
16.8	9593	1.5	87.1	75000	A903_87.1 S5 M5LA4	156	A903_87.1 P180 BN180M4	157
18.2	8855	1.6	80.4	75000	A903_80.4 S5 M5LA4	156	A903_80.4 P180 BN180M4	157
19.6	8206	1.7	74.5	75000	A903_74.5 S5 M5LA4	156	A903_74.5 P180 BN180M4	157
20.2	7973	1.0	72.4	55600	A803_72.4 S5 M5LA4	153	A803_72.4 P180 BN180M4	154
21.2	7575	1.8	68.8	75000	A903_68.8 S5 M5LA4	156	A903_68.8 P180 BN180M4	157
21.9	7360	1.1	66.8	55100			A803_66.8 P180 BN180M4	154
24.4	6586	1.2	59.8	54700	A803_59.8 S5 M5LA4	153	A803_59.8 P180 BN180M4	154
24.5	6568	2.1	59.6	75000	A903_59.6 S5 M5LA4	156	A903_59.6 P180 BN180M4	157
26.5	6080	1.3	55.2	54100	A803_55.2 S5 M5LA4	153	A803_55.2 P180 BN180M4	154
26.5	6063	2.3	55.0	74900	A903_55.0 S5 M5LA4	156	A903_55.0 P180 BN180M4	157
29.8	5399	0.9	49.0	49600	A703_49.0 S5 M5LA4	150	A703_49.0 P180 BN180M4	151
30	5322	2.6	48.3	73100			A903_48.3 P180 BN180M4	157
30	5309	1.5	48.2	53200	A803_48.2 S5 M5LA4	153	A803_48.2 P180 BN180M4	154
32	4983	1.0	45.2	49000	A703_45.2 S5 M5LA4	150	A703_45.2 P180 BN180M4	151
33	4912	2.9	44.6	71800			A903_44.6 P180 BN180M4	157
33	4900	1.5	44.5	52500	A803_44.5 S5 M5LA4	153	A803_44.5 P180 BN180M4	154
38	4276	3.3	38.8	69700			A903_38.8 P180 BN180M4	157
38	4242	1.8	38.5	51400			A803_38.5 P180 BN180M4	154
38	4229	1.1	38.4	48000	A703_38.4 S5 M5LA4	150	A703_38.4 P180 BN180M4	151
41	3947	3.5	35.8	68500			A903_35.8 P180 BN180M4	157
41	3916	1.8	35.5	50600			A803_35.5 P180 BN180M4	154
41	3904	1.2	35.4	47300	A703_35.4 S5 M5LA4	150	A703_35.4 P180 BN180M4	151
48	3369	1.9	30.6	49300			A803_30.6 P180 BN180M4	154
49	3316	1.4	30.1	46100			A703_30.1 P180 BN180M4	151
52	3110	2.1	28.2	48500			A803_28.2 P180 BN180M4	154
52	3069	0.9	27.9	30000	A603_27.9 S5 M5LA4	146	A603_27.9 P180 BN180M4	147
53	3061	1.4	27.8	45300			A703_27.8 P180 BN180M4	151
57	2833	1.0	25.7	30000	A603_25.7 S5 M5LA4	146	A603_25.7 P180 BN180M4	147
60	2699	2.5	24.5	47200			A803_24.5 P180 BN180M4	154
62	2591	1.7	23.5	43900			A703_23.5 P180 BN180M4	151
65	2492	2.5	22.6	46300			A803_22.6 P180 BN180M4	154
69	2347	1.7	21.3	43000	A703_21.3 S5 M5LA4	150	A703_21.3 P180 BN180M4	151
70	2308	2.8	20.9	45600	A803_20.9 S5 M5LA4	153	A803_20.9 P180 BN180M4	154
74	2167	1.7	19.7	42300	A703_19.7 S5 M5LA4	150	A703_19.7 P180 BN180M4	151
75	2131	2.8	19.3	44800	A803_19.3 S5 M5LA4	153	A803_19.3 P180 BN180M4	154
87	1905	1.0	16.7	30000	A602_16.7 S5 M5LA4	146	A602_16.7 P180 BN180M4	147
87	1839	2.2	16.7	40800	A703_16.7 S5 M5LA4	150	A703_16.7 P180 BN180M4	151
93	1785	1.0	15.7	25000	A552_15.7 S5 M5LA4	142	A552_15.7 P180 BN180M4	142
95	1697	2.2	15.4	40100	A703_15.4 S5 M5LA4	150	A703_15.4 P180 BN180M4	151
112	1488	1.2	13.1	24100	A552_13.1 S5 M5LA4	142	A552_13.1 P180 BN180M4	142
112	1442	2.7	13.1	38600	A703_13.1 S5 M5LA4	150	A703_13.1 P180 BN180M4	151
115	1446	1.4	12.7	30000	A602_12.7 S5 M5LA4	146	A602_12.7 P180 BN180M4	147
121	1331	2.7	12.1	37800	A703_12.1 S5 M5LA4	150	A703_12.1 P180 BN180M4	151
123	1306	1.2	23.8	21600	A553_23.8 S5 M5SC2	142	A553_23.8 P160 BN160L2	142
141	1179	1.5	10.4	22900	A552_10.4 S5 M5LA4	142	A552_10.4 P180 BN180M4	142
142	1174	1.7	10.3	29900	A602_10.3 S5 M5LA4	146	A602_10.3 P180 BN180M4	147
143	1127	2.9	10.2	36300	A703_10.2 S5 M5LA4	150	A703_10.2 P180 BN180M4	151
150	1108	0.9	9.7	9530	A502_9.7 S5 M5LA4	138	A502_9.7 P180 BN180M4	139
155	1040	2.9	9.4	35600	A703_9.4 S5 M5LA4	150	A703_9.4 P180 BN180M4	151
173	963	1.9	8.5	21900	A552_8.5 S5 M5LA4	142	A552_8.5 P180 BN180M4	142
186	895	2.2	7.9	27900	A602_7.9 S5 M5LA4	146	A602_7.9 P180 BN180M4	147
189	881	1.1	7.7	9260			A502_7.7 P180 BN180M4	139
228	730	2.3	6.4	20400	A552_6.4 S5 M5LA4	142	A552_6.4 P180 BN180M4	142
295	563	2.8	4.9	19100	A552_4.9 S5 M5LA4	142	A552_4.9 P180 BN180M4	142
379	439	1.7	7.7	8100			A502_7.7 P160 BN160L2	139

22 kW



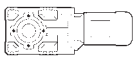

n ₂ min ⁻¹	M ₂ Nm	S	i	R _{n2} N				
12.5	15317	0.9	116.9	75000			A903_116.9 P180 BN180L4	157
13.7	13996	1.0	106.8	75000			A903_106.8 P180 BN180L4	157
14.8	12919	1.1	98.6	75000			A903_98.6 P180 BN180L4	157



22 kW

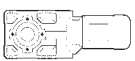

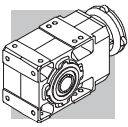

n₂ min ⁻¹	M₂ Nm	S	i	R_{n2} N				
16.8	11408	1.2	87.1	75000			A903_87.1 P180 BN180L4	157
18.2	10530	1.3	80.4	75000			A903_80.4 P180 BN180L4	157
19.6	9758	1.4	74.5	75000			A903_74.5 P180 BN180L4	157
21.2	9008	1.6	68.8	75000			A903_68.8 P180 BN180L4	157
21.9	8753	0.9	66.8	51900			A803_66.8 P180 BN180L4	154
24.4	7832	1.0	59.8	51800			A803_59.8 P180 BN180L4	154
24.5	7811	1.8	59.6	73800			A903_59.6 P180 BN180L4	157
26.5	7230	1.1	55.2	51400			A803_55.2 P180 BN180L4	154
26.5	7210	1.9	55.0	72700			A903_55.0 P180 BN180L4	157
30	6328	2.2	48.3	71100			A903_48.3 P180 BN180L4	157
30	6313	1.3	48.2	50900			A803_48.2 P180 BN180L4	154
33	5842	2.4	44.6	70000			A903_44.6 P180 BN180L4	157
33	5827	1.3	44.5	50300			A803_44.5 P180 BN180L4	154
38	5085	2.8	38.8	68100			A903_38.8 P180 BN180L4	157
38	5044	1.5	38.5	49500			A803_38.5 P180 BN180L4	154
38	5029	1.0	38.4	46000			A703_38.4 P180 BN180L4	151
41	4694	2.9	35.8	67000			A903_35.8 P180 BN180L4	157
41	4656	1.5	35.5	48900			A803_35.5 P180 BN180L4	154
41	4642	1.0	35.4	45500			A703_35.4 P180 BN180L4	151
46	4127	3.4	31.5	65200			A903_31.5 P180 BN180L4	157
48	4006	1.6	30.6	47800			A803_30.6 P180 BN180L4	154
49	3944	1.2	30.1	44500			A703_30.1 P180 BN180L4	151
50	3810	3.4	29.1	64000			A903_29.1 P180 BN180L4	157
52	3698	1.8	28.2	47100			A803_28.2 P180 BN180L4	154
53	3640	1.2	27.8	43900			A703_27.8 P180 BN180L4	151
60	3210	2.1	24.5	45900			A803_24.5 P180 BN180L4	154
62	3082	1.4	23.5	42700			A703_23.5 P180 BN180L4	151
65	2963	2.1	22.6	45200			A803_22.6 P180 BN180L4	154
69	2791	1.4	21.3	41900			A703_21.3 P180 BN180L4	151
70	2745	2.4	20.9	44600			A803_20.9 P180 BN180L4	154
74	2577	1.4	19.7	41200			A703_19.7 P180 BN180L4	151
75	2534	2.4	19.3	43800			A803_19.3 P180 BN180L4	154
87	2193	3.0	16.7	42500			A803_16.7 P180 BN180L4	154
87	2187	1.8	16.7	39900			A703_16.7 P180 BN180L4	151
94	2024	3.0	15.5	41700			A803_15.5 P180 BN180L4	154
95	2018	1.8	15.4	39200			A703_15.4 P180 BN180L4	151
112	1770	1.0	13.1	23500			A552_13.1 P180 BN180L4	142
112	1715	2.2	13.1	37900			A703_13.1 P180 BN180L4	151
115	1719	1.2	12.7	30000			A602_12.7 P180 BN180L4	147
121	1583	2.2	12.1	37200			A703_12.1 P180 BN180L4	151
123	1553	1.0	23.8	20900	A553_23.8 S5 M5LA2	142	A553_23.8 P180 BN180M2	142
141	1401	1.3	10.4	22400			A552_10.4 P180 BN180L4	142
142	1396	1.4	10.3	29300			A602_10.3 P180 BN180L4	147
143	1340	2.4	10.2	35800			A703_10.2 P180 BN180L4	151
155	1237	2.4	9.4	35100			A703_9.4 P180 BN180L4	151
173	1145	1.6	8.5	21400			A552_8.5 P180 BN180L4	142
186	1064	1.9	7.9	27500			A602_7.9 P180 BN180L4	147
189	1047	0.9	7.7	8760			A502_7.7 P180 BN180L4	139
228	868	2.0	6.4	20100			A552_6.4 P180 BN180L4	142
283	698	2.6	10.4	19100	A552_10.4 S5 M5LA2	142	A552_10.4 P180 BN180M2	142
295	669	2.4	4.9	18900			A552_4.9 P180 BN180L4	142
346	571	3.0	8.5	18200	A552_8.5 S5 M5LA2	142	A552_8.5 P180 BN180M2	142
379	522	1.4	7.7	7860			A502_7.7 P180 BN180M2	139

30 kW





n₂ min ⁻¹	M₂ Nm	S	i	R_{n2} N				
16.8	15556	0.9	87.1	70100			A903_87.1 P200 BN200L4	157
18.2	14360	1.0	80.4	70000			A903_80.4 P200 BN200L4	157
19.6	13307	1.1	74.5	69700			A903_74.5 P200 BN200L4	157
21.2	12283	1.1	68.8	69200			A903_68.8 P200 BN200L4	157
24.5	10651	1.3	59.6	68500			A903_59.6 P200 BN200L4	157
26.5	9832	1.4	55.0	67800			A903_55.0 P200 BN200L4	157
30.0	8630	1.6	48.3	66900			A903_48.3 P200 BN200L4	157
30	8609	0.9	48.2	45700			A803_48.2 P200 BN200L4	154
33	7966	1.8	44.6	66000			A903_44.6 P200 BN200L4	157



30 kW



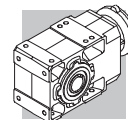

n₂ min ⁻¹	M₂ Nm	S	i	R_{n2} N				
33	7946	0.9	44.5	45500			A803_44.5 P200 BN200L4	154
38	6934	2.0	38.8	64700			A903_38.8 P200 BN200L4	157
38	6879	1.1	38.5	45300			A803_38.5 P200 BN200L4	154
41	6400	2.1	35.8	63800			A903_35.8 P200 BN200L4	157
41	6349	1.1	35.5	45000			A803_35.5 P200 BN200L4	154
46	5628	2.5	31.5	62400			A903_31.5 P200 BN200L4	157
48	5463	1.2	30.6	44500			A803_30.6 P200 BN200L4	154
50	5195	2.5	29.1	61400			A903_29.1 P200 BN200L4	157
52	5043	1.3	28.2	44000			A803_28.2 P200 BN200L4	154
60	4377	1.5	24.5	43300			A803_24.5 P200 BN200L4	154
61	4307	3.1	24.1	59200			A903_24.1 P200 BN200L4	157
62	4202	1.0	23.5	40100			A703_23.5 P200 BN200L4	151
65	4041	1.5	22.6	42700			A803_22.6 P200 BN200L4	154
66	3976	3.1	22.3	58200			A903_22.3 P200 BN200L4	157
70	3752	3.3	21.0	57500			A903_21.0 P200 BN200L4	157
70	3743	1.7	20.9	42300			A803_20.9 P200 BN200L4	154
75	3463	3.3	19.4	56500			A903_19.4 P200 BN200L4	157
75	3455	1.8	19.3	41700			A803_19.3 P200 BN200L4	154
87	2991	2.2	16.7	40700			A803_16.7 P200 BN200L4	154
87	2982	1.3	16.7	38100			A703_16.7 P200 BN200L4	151
94	2761	2.2	15.5	40000			A803_15.5 P200 BN200L4	154
95	2752	1.3	15.4	37500			A703_15.4 P200 BN200L4	151
110	2375	2.8	13.3	38900			A803_13.3 P200 BN200L4	154
112	2338	1.6	13.1	36400			A703_13.1 P200 BN200L4	151
119	2192	2.8	12.3	38200			A803_12.3 P200 BN200L4	154
121	2158	1.6	12.1	35800			A703_12.1 P200 BN200L4	151
125	2094	1.7	23.5	35600			A703_23.5 P200 BN200LA2	151
137	1903	3.4	10.7	37100			A803_10.7 P200 BN200L4	154
143	1827	1.8	10.2	34600			A703_10.2 P200 BN200L4	151
148	1757	3.4	9.8	36500			A803_9.8 P200 BN200L4	154
155	1687	1.8	9.4	34000			A703_9.4 P200 BN200L4	151
176	1486	2.3	16.7	33100			A703_16.7 P200 BN200LA2	151
190	1371	2.3	15.4	32500			A703_15.4 P200 BN200LA2	151
224	1165	2.7	13.1	31300			A703_13.1 P200 BN200LA2	151
243	1075	2.7	12.1	30600			A703_12.1 P200 BN200LA2	151
287	910	3.2	10.2	29400			A703_10.2 P200 BN200LA2	151
310	840	3.2	9.4	28800			A703_9.4 P200 BN200LA2	151

37 kW





n₂ min ⁻¹	M₂ Nm	S	i	R_{n2} N				
21.5	14945	0.9	68.8	63900			A903_68.8 P225 BN225S4	157
24.8	12959	1.1	59.6	63900			A903_59.6 P225 BN225S4	157
26.9	11962	1.2	55.0	63600			A903_55.0 P225 BN225S4	157
31	10499	1.3	48.3	63100			A903_48.3 P225 BN225S4	157
33	9692	1.4	44.6	62500			A903_44.6 P225 BN225S4	157
38	8436	1.7	38.8	61700			A903_38.8 P225 BN225S4	157
38	8369	0.9	38.5	41700			A803_38.5 P225 BN225S4	154
41	7787	1.8	35.8	61000			A903_35.8 P225 BN225S4	157
42	7725	0.9	35.5	41600			A803_35.5 P225 BN225S4	154
47	6847	2.0	31.5	59900			A903_31.5 P225 BN225S4	157
48	6647	1.0	30.6	41600			A803_30.6 P225 BN225S4	154
51	6321	2.1	29.1	59100			A903_29.1 P225 BN225S4	157
52	6135	1.1	28.2	41300			A803_28.2 P225 BN225S4	154
60	5326	1.3	24.5	40900			A803_24.5 P225 BN225S4	154
61	5241	2.5	24.1	57300			A903_24.1 P225 BN225S4	157
65	4916	1.3	22.6	40500			A803_22.6 P225 BN225S4	154
67	4837	2.5	22.3	56400			A903_22.3 P225 BN225S4	157
70	4565	2.7	21.0	55900			A903_21.0 P225 BN225S4	157
71	4554	1.4	20.9	40300			A803_20.9 P225 BN225S4	154
76	4214	2.7	19.4	54900			A903_19.4 P225 BN225S4	157
77	4204	1.4	19.3	39800			A803_19.3 P225 BN225S4	154
88	3668	3.2	16.9	53400			A903_16.9 P225 BN225S4	157
88	3639	1.8	16.7	39100			A803_16.7 P225 BN225S4	154
95	3386	3.2	15.6	52500			A903_15.6 P225 BN225S4	157
96	3359	1.8	15.5	38500			A803_15.5 P225 BN225S4	154







37 kW

n₂ min ⁻¹	M₂ Nm	S	i	R_{n2} N			 IEC 	
111	2890	2.3	13.3	37600			A803_13.3 P225 BN225S4	154
121	2667	2.3	12.3	37000			A803_12.3 P225 BN225S4	154
139	2316	2.8	10.7	36100			A803_10.7 P225 BN225S4	154
151	2137	2.8	9.8	35500			A803_9.8 P225 BN225S4	154

45 kW

n₂ min ⁻¹	M₂ Nm	S	i	R_{n2} N			 IEC 	
26.9	14549	1.0	55.0	58700			A903_55.0 P225 BN225M4	157
31	12769	1.1	48.3	58900			A903_48.3 P225 BN225M4	157
33	11787	1.2	44.6	58600			A903_44.6 P225 BN225M4	157
38	10260	1.4	38.8	58300			A903_38.8 P225 BN225M4	157
41	9471	1.5	35.8	57800			A903_35.8 P225 BN225M4	157
47	8328	1.7	31.5	57200			A903_31.5 P225 BN225M4	157
51	7687	1.7	29.1	56600			A903_29.1 P225 BN225M4	157
60	6477	1.0	24.5	38300			A803_24.5 P225 BN225M4	154
61	6374	2.1	24.1	55200			A903_24.1 P225 BN225M4	157
65	5979	1.0	22.6	38100			A803_22.6 P225 BN225M4	154
67	5883	2.1	22.3	54500			A903_22.3 P225 BN225M4	157
70	5552	2.2	21.0	54000			A903_21.0 P225 BN225M4	157
71	5539	1.2	20.9	38000			A803_20.9 P225 BN225M4	154
76	5125	2.3	19.4	53200			A903_19.4 P225 BN225M4	157
77	5112	1.2	19.3	37700			A803_19.3 P225 BN225M4	154
88	4461	2.7	16.9	52000			A903_16.9 P225 BN225M4	157
88	4425	1.5	16.7	37300			A803_16.7 P225 BN225M4	154
95	4118	2.7	15.6	51100			A903_15.6 P225 BN225M4	157
96	4085	1.5	15.5	36900			A803_15.5 P225 BN225M4	154
108	3621	3.1	13.7	49900			A903_13.7 P225 BN225M4	157
111	3515	1.9	13.3	36200			A803_13.3 P225 BN225M4	154
117	3342	3.1	12.6	49000			A903_12.6 P225 BN225M4	157
121	3244	1.9	12.3	35700			A803_12.3 P225 BN225M4	154
139	2816	2.3	10.7	34900			A803_10.7 P225 BN225M4	154
141	2771	3.5	10.5	47100			A903_10.5 P225 BN225M4	157
151	2600	2.3	9.8	34400			A803_9.8 P225 BN225M4	154
153	2558	3.5	9.7	46200			A903_9.7 P225 BN225M4	157

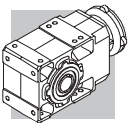

55 kW

n₂ min ⁻¹	M₂ Nm	S	i	R_{n2} N			 IEC 	
33	14406	1.0	44.6	53900			A903_44.6 P250 BN250M4	157
38	12540	1.1	38.8	54100			A903_38.8 P250 BN250M4	157
41	11575	1.2	35.8	54000			A903_35.8 P250 BN250M4	157
47	10179	1.4	31.5	53800			A903_31.5 P250 BN250M4	157
51	9396	1.4	29.1	53400			A903_29.1 P250 BN250M4	157
61	7790	1.7	24.1	52600			A903_24.1 P250 BN250M4	157
67	7191	1.7	22.3	52000			A903_22.3 P250 BN250M4	157
70	6786	1.8	21.0	51700			A903_21.0 P250 BN250M4	157
76	6264	1.8	19.4	51100			A903_19.4 P250 BN250M4	157
88	5452	2.2	16.9	50100			A903_16.9 P250 BN250M4	157
95	5033	2.2	15.6	49400			A903_15.6 P250 BN250M4	157
108	4425	2.5	13.7	48400			A903_13.7 P250 BN250M4	157
117	4085	2.6	12.6	47600			A903_12.6 P250 BN250M4	157
141	3387	2.9	10.5	45900			A903_10.5 P250 BN250M4	157
153	3126	2.9	9.7	45100			A903_9.7 P250 BN250M4	157

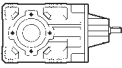

A 10

150 Nm

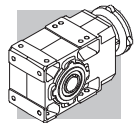

	i	n ₁ = 2800 min ⁻¹					n ₁ = 1400 min ⁻¹					
		n ₂ min ⁻¹	M _{n2} Nm	P _{n1} kW	R _{n1} N	R _{n2} N	n ₂ min ⁻¹	M _{n2} Nm	P _{n1} kW	R _{n1} N	R _{n2} N	
A 10 2_5.5	5.5	512	73	4.2	—	1830	256	73	2.1	960	2460	119
A 10 2_6.3	6.3	442	80	3.9	—	1900	221	80	2.0	830	2560	
A 10 2_7.2	7.2	388	92	4.0	—	1910	194	93	2.0	630	2600	
A 10 2_8.5	8.5	329	92	3.4	—	2060	164	93	1.7	720	2790	
A 10 2_9.6	9.6	291	102	3.3	—	2090	146	128	2.1	—	2650	
A 10 2_10.6	10.6	265	125	3.7	540	2010	133	150	2.2	810	2590	
A 10 2_12.3	12.3	228	110	2.8	—	2280	114	138	1.7	—	2880	
A 10 2_13.9	13.9	201	135	3.0	620	2220	101	150	1.7	1080	2960	
A 10 2_16.4	16.4	170	140	2.7	610	2370	85	150	1.4	1140	3200	
A 10 2_18.6	18.6	151	147	2.5	650	2460	75	150	1.3	1180	3380	
A 10 2_21.4	21.4	131	150	2.2	650	2610	66	150	1.1	1200	3600	
A 10 2_23.8	23.8	118	150	2.0	750	2750	59	150	0.98	1220	3780	
A 10 2_25.5	25.5	110	150	1.8	750	2840	55	150	0.92	1220	3900	
A 10 2_28.6	28.6	98	150	1.6	830	3000	49	150	0.82	1250	4100	
A 10 2_32.2	32.2	87	150	1.5	880	3170	43	150	0.73	1270	4310	
A 10 2_35.1	35.1	80	150	1.3	880	3300	40	150	0.67	1270	4470	
A 10 2_40.9	40.9	69	150	1.1	910	3530	34	150	0.57	1300	4770	
A 10 2_45.4	45.4	62	150	1.0	910	3700	31	150	0.52	1300	4980	
A 10 2_51.3	51.3	55	150	0.91	910	3910	27.3	150	0.46	1290	5240	
A 10 2_58.6	58.6	48	150	0.80	920	4140	23.9	150	0.40	1300	5500	
A 10 2_65.9	65.9	42	150	0.71	920	4360	21.2	150	0.35	1300	5500	
A 10 2_76.4	76.4	37	150	0.61	930	4640	18.3	150	0.31	1300	5500	
A 10 2_91.6	91.6	31	130	0.44	1020	5160	15.3	130	0.22	1300	5500	

(—) Interpellare il ns. servizio tecnico comunicando i dati relativi al carico radiale (senso di rotazione, orientamento, posizione)
 (—) Contact our technical service department advising radial load data (rotation direction, orientation, position)
 (—) Nehmen Sie bitte Kontakt mit unserem Applikationsdienst und Querkraftsdaten angeben (Drehrichtung, Orientierung, Anordnung)
 (—) Consulter notre service technique en donnant les détails concernant la charge radiale (sens de rotation, indexage, position)



A 10

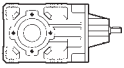

150 Nm

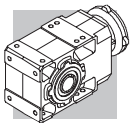
	i	n ₁ = 900 min ⁻¹					n ₁ = 500 min ⁻¹					
		n ₂ min ⁻¹	M _{n2} Nm	P _{n1} kW	R _{n1} N	R _{n2} N	n ₂ min ⁻¹	M _{n2} Nm	P _{n1} kW	R _{n1} N	R _{n2} N	
A 10 2_5.5	5.5	165	73	1.3	1300	2950	91	73	0.74	1300	3720	119
A 10 2_6.3	6.3	142	80	1.3	1300	3070	79	80	0.70	1300	4100	
A 10 2_7.2	7.2	125	93	1.3	1160	3130	69	93	0.72	1300	3970	
A 10 2_8.5	8.5	106	95	1.1	1200	3330	59	110	0.72	1300	4100	
A 10 2_9.6	9.6	94	128	1.3	500	3230	52	128	0.74	1300	4160	
A 10 2_10.6	10.6	85	150	1.4	1300	3200	47	150	0.79	1300	4160	
A 10 2_12.3	12.3	73	150	1.2	180	3420	41	150	0.68	1030	4430	
A 10 2_13.9	13.9	65	150	1.1	1300	3630	36	150	0.60	1300	4680	
A 10 2_16.4	16.4	55	150	0.91	1300	3900	30	150	0.51	1300	5010	
A 10 2_18.6	18.6	48	150	0.81	1300	4120	26.9	150	0.45	1300	5270	
A 10 2_21.4	21.4	42	150	0.70	1300	4370	23.4	150	0.39	1300	5500	
A 10 2_23.8	23.8	38	150	0.63	1300	4570	21.0	150	0.35	1300	5500	
A 10 2_25.5	25.5	35	150	0.59	1300	4710	19.6	150	0.33	1300	5500	
A 10 2_28.6	28.6	31	150	0.53	1300	4940	17.5	150	0.29	1300	5500	
A 10 2_32.2	32.2	28.0	150	0.47	1300	5190	15.5	150	0.26	1300	5500	
A 10 2_35.1	35.1	25.6	150	0.43	1300	5380	14.2	150	0.24	1300	5500	
A 10 2_40.9	40.9	22.0	150	0.37	1300	5500	12.2	150	0.20	1300	5500	
A 10 2_45.4	45.4	19.8	150	0.33	1300	5500	11.0	150	0.18	1300	5500	
A 10 2_51.3	51.3	17.6	150	0.29	1300	5500	9.8	150	0.16	1300	5500	
A 10 2_58.6	58.6	15.4	150	0.26	1300	5500	8.5	150	0.14	1300	5500	
A 10 2_65.9	65.9	13.7	150	0.23	1300	5500	7.6	150	0.13	1300	5500	
A 10 2_76.4	76.4	11.8	150	0.20	1300	5500	6.5	150	0.11	1300	5500	
A 10 2_91.6	91.6	9.8	130	0.14	1300	5500	5.5	130	0.08	1300	5500	



A 20

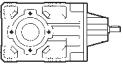

250 Nm

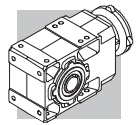
	i	n ₁ = 2800 min ⁻¹					n ₁ = 1400 min ⁻¹					
		n ₂ min ⁻¹	M _{n2} Nm	P _{n1} kW	R _{n1} N	R _{n2} N	n ₂ min ⁻¹	M _{n2} Nm	P _{n1} kW	R _{n1} N	R _{n2} N	
A 20 2_5.4	5.4	523	96	5.6	610	1910	262	121	3.5	770	2400	123
A 20 2_6.5	6.5	428	107	5.1	490	2010	214	135	3.2	610	2530	
A 20 2_7.3	7.3	384	113	4.8	510	2070	192	143	3.1	630	2600	
A 20 2_8.4	8.4	334	116	4.3	510	2180	167	146	2.7	650	2750	
A 20 2_9.4	9.4	299	122	4.1	530	2260	149	154	2.6	660	2840	
A 20 2_10.3	10.3	271	183	5.5	650	1970	135	225	3.4	890	2520	
A 20 2_12.0	12.0	234	128	3.3	550	2280	117	161	2.1	690	3120	
A 20 2_14.1	14.1	199	199	4.4	750	2210	99	245	2.7	960	2820	
A 20 2_16.2	16.2	173	209	4.0	700	2310	87	250	2.4	1040	2990	
A 20 2_18.1	18.1	155	216	3.7	760	2400	77	250	2.2	1210	3170	
A 20 2_21.2	21.2	132	226	3.3	710	2540	66	250	1.8	1290	3430	
A 20 2_23.1	23.1	121	232	3.1	710	2620	61	250	1.7	1360	3580	
A 20 2_26.5	26.5	106	241	2.8	660	2750	53	250	1.5	1410	3820	
A 20 2_29.2	29.2	96	249	2.7	670	2850	48	250	1.3	1510	4000	
A 20 2_31.3	31.3	89	250	2.5	660	2940	45	250	1.2	1510	4130	
A 20 2_35.4	35.4	79	250	2.2	800	3140	40	250	1.1	1650	4380	
A 20 2_39.6	39.6	71	250	2.0	880	3320	35	250	0.98	1710	4600	
A 20 2_43.2	43.2	65	250	1.8	880	3460	32	250	0.90	1710	4790	
A 20 2_48.3	48.3	58	250	1.6	920	3650	29.0	250	0.81	1720	5030	
A 20 2_53.7	53.7	52	250	1.5	920	3840	26.1	250	0.73	1720	5270	
A 20 2_63.1	63.1	44	245	1.2	1040	4180	22.2	245	0.61	1740	5680	
A 20 2_71.0	71.0	39	210	0.92	1360	4640	19.7	210	0.46	1790	6200	
A 20 2_79.9	79.9	35	210	0.82	1360	4880	17.5	210	0.41	1790	6200	
A 20 2_92.3	92.3	30	200	0.68	1380	5250	15.2	200	0.34	1810	6200	
A 20 3_109.2	109.2	25.6	165	0.49	1180	5900	12.8	205	0.30	1300	6200	
A 20 3_120.5	120.5	23.2	168	0.45	1130	6110	11.6	210	0.28	1300	6200	
A 20 3_129.1	129.1	21.7	175	0.44	1210	6200	10.8	215	0.27	1300	6200	
A 20 3_146.1	146.1	19.2	183	0.40	1160	6200	9.6	230	0.25	1300	6200	
A 20 3_163.4	163.4	17.1	190	0.37	1240	6200	8.6	235	0.23	1300	6200	
A 20 3_178.3	178.3	15.7	195	0.35	1200	6200	7.9	245	0.22	1300	6200	
A 20 3_199.2	199.2	14.1	200	0.32	1270	6200	7.0	250	0.20	1300	6200	
A 20 3_221.3	221.3	12.7	203	0.30	1240	6200	6.3	250	0.18	1300	6200	
A 20 3_260.5	260.5	10.8	214	0.26	1270	6200	5.4	250	0.15	1300	6200	
A 20 3_292.8	292.8	9.6	218	0.24	1300	6200	4.8	250	0.14	1300	6200	
A 20 3_329.4	329.4	8.5	221	0.22	1300	6200	4.3	250	0.12	1300	6200	
A 20 3_380.8	380.8	7.4	226	0.19	1300	6200	3.7	250	0.11	1300	6200	



A 20

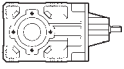

250 Nm

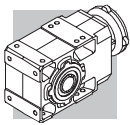
	i	n ₁ = 900 min ⁻¹					n ₁ = 500 min ⁻¹					
		n ₂ min ⁻¹	M _{n2} Nm	P _{n1} kW	R _{n1} N	R _{n2} N	n ₂ min ⁻¹	M _{n2} Nm	P _{n1} kW	R _{n1} N	R _{n2} N	
A 20 2_5.4	5.4	168	140	2.6	900	2780	93	170	1.8	1100	3390	123
A 20 2_6.5	6.5	138	156	2.4	720	2930	76	190	1.6	860	3570	
A 20 2_7.3	7.3	123	165	2.3	740	3020	69	201	1.5	890	3670	
A 20 2_8.4	8.4	108	170	2.0	730	3180	60	206	1.4	910	3870	
A 20 2_9.4	9.4	96	179	1.9	760	3290	53	210	1.2	1090	4050	
A 20 2_10.3	10.3	87	250	2.4	1190	2990	48	250	1.3	2200	3980	
A 20 2_12.0	12.0	75	187	1.6	790	2990	42	210	0.98	1336	4510	
A 20 2_14.1	14.1	64	250	1.8	1610	3490	36	250	0.99	2200	4590	
A 20 2_16.2	16.2	56	250	1.6	1690	3730	31	250	0.86	2200	4880	
A 20 2_18.1	18.1	50	250	1.4	1860	3930	27.6	250	0.77	2200	5140	
A 20 2_21.2	21.2	42	250	1.2	1940	4230	23.6	250	0.66	2200	5500	
A 20 2_23.1	23.1	39	250	1.1	1970	4400	21.6	250	0.60	2200	5710	
A 20 2_26.5	26.5	34	250	0.95	1980	4680	18.9	250	0.53	2200	6050	
A 20 2_29.2	29.2	31	250	0.86	2000	4890	17.1	250	0.48	2200	6200	
A 20 2_31.3	31.3	28.7	250	0.80	2000	5040	16.0	250	0.44	2200	6200	
A 20 2_35.4	35.4	25.4	250	0.71	2020	5330	14.1	250	0.39	2200	6200	
A 20 2_39.6	39.6	22.7	250	0.63	2040	5590	12.6	250	0.35	2200	6200	
A 20 2_43.2	43.2	20.8	250	0.58	2040	5800	11.6	250	0.32	2200	6200	
A 20 2_48.3	48.3	18.6	250	0.52	2040	6080	10.4	250	0.29	2200	6200	
A 20 2_53.7	53.7	16.8	250	0.47	2050	6200	9.3	250	0.26	2200	6200	
A 20 2_63.1	63.1	14.3	245	0.39	2060	6200	7.9	245	0.22	2200	6200	
A 20 2_71.0	71.0	12.7	210	0.30	2120	6200	7.0	210	0.16	2200	6200	
A 20 2_79.9	79.9	11.3	210	0.26	2120	6200	6.3	210	0.15	2200	6200	
A 20 2_92.3	92.3	9.7	200	0.22	2140	6200	5.4	200	0.12	2200	6200	
A 20 3_109.2	109.2	8.2	240	0.23	1300	6200	4.6	250	0.13	1300	6200	
A 20 3_120.5	120.5	7.5	245	0.21	1300	6200	4.1	250	0.12	1300	6200	
A 20 3_129.1	129.1	7.0	250	0.20	1300	6200	3.9	250	0.11	1300	6200	
A 20 3_146.1	146.1	6.2	250	0.18	1300	6200	3.4	250	0.10	1300	6200	
A 20 3_163.4	163.4	5.5	250	0.16	1300	6200	3.1	250	0.09	1300	6200	
A 20 3_178.3	178.3	5.0	250	0.15	1300	6200	2.8	250	0.08	1300	6200	
A 20 3_199.2	199.2	4.5	250	0.13	1300	6200	2.5	250	0.07	1300	6200	
A 20 3_221.3	221.3	4.1	250	0.12	1300	6200	2.3	250	0.06	1300	6200	
A 20 3_260.5	260.5	3.5	250	0.10	1300	6200	1.9	250	0.06	1300	6200	
A 20 3_292.8	292.8	3.1	250	0.09	1300	6200	1.7	250	0.05	1300	6200	
A 20 3_329.4	329.4	2.7	250	0.08	1300	6200	1.5	250	0.04	1300	6200	
A 20 3_380.8	380.8	2.4	250	0.07	1300	6200	1.3	250	0.04	1300	6200	



A 30

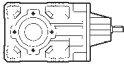

410 Nm

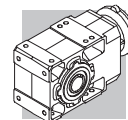
	i	n ₁ = 2800 min ⁻¹					n ₁ = 1400 min ⁻¹					
		n ₂ min ⁻¹	M _{n2} Nm	P _{n1} kW	R _{n1} N	R _{n2} N	n ₂ min ⁻¹	M _{n2} Nm	P _{n1} kW	R _{n1} N	R _{n2} N	
A 30 2_5.4	5.4	517	175	10.1	1130	2480	259	220	6.3	1430	3130	127
A 30 2_6.4	6.4	437	185	9.0	1120	2630	218	230	5.6	1470	3330	
A 30 2_7.0	7.0	399	194	8.6	1140	2690	199	245	5.4	1430	3380	
A 30 2_8.5	8.5	331	200	7.4	1220	2900	165	250	4.6	1570	3660	
A 30 2_9.3	9.3	301	214	7.2	1140	2950	150	270	4.5	1440	3710	
A 30 2_10.5	10.5	268	278	8.3	1800	2770	134	340	5.1	2200	3550	
A 30 2_11.8	11.8	238	230	6.1	1130	3200	119	290	3.8	1420	4030	
A 30 2_13.6	13.6	206	301	6.9	1830	3030	103	370	4.3	2200	3870	
A 30 2_16.3	16.3	171	318	6.1	1830	3240	86	385	3.7	2200	4170	
A 30 2_18.0	18.0	156	327	5.7	1840	3350	78	400	3.5	2200	4290	
A 30 2_20.5	20.5	136	340	5.2	1830	3510	68	410	3.1	2200	4530	
A 30 2_22.8	22.8	123	351	4.8	1850	3640	62	410	2.8	2200	4770	
A 30 2_26.5	26.5	106	367	4.3	1840	3850	53	410	2.4	2200	5150	
A 30 2_29.3	29.3	96	378	4.0	1847	3980	48	410	2.2	2200	5400	
A 30 2_33.4	33.4	84	393	3.7	1840	4170	42	410	1.9	2200	5750	
A 30 2_36.6	36.6	76	404	3.4	1840	4310	38	410	1.7	2200	6010	
A 30 2_39.3	39.3	71	410	3.3	1810	4430	36	410	1.6	2200	6200	
A 30 2_43.4	43.4	64	410	2.9	1850	4660	32	410	1.5	2200	6490	
A 30 2_48.3	48.3	58	410	2.6	1860	4920	29.0	410	1.3	2200	6810	
A 30 2_52.7	52.7	53	410	2.4	1860	5130	26.6	410	1.2	2200	7080	
A 30 2_59.4	59.4	47	400	2.1	1890	5500	23.6	400	1.0	2200	7530	
A 30 2_66.0	66.0	42	390	1.8	1900	5840	21.2	390	0.92	2200	7940	
A 30 2_76.5	76.5	37	350	1.4	1950	6480	18.3	350	0.71	2200	8690	
A 30 2_86.7	86.7	32	320	1.2	2000	7010	16.2	320	0.58	2200	9310	
A 30 2_97.5	97.5	28.7	300	0.96	2020	7480	14.4	300	0.48	2200	9600	
A 30 3_109.1	109.1	25.7	240	0.71	1300	8240	12.8	300	0.44	1300	9600	
A 30 3_120.5	120.5	23.2	243	0.65	1120	8540	11.6	300	0.40	1300	9600	
A 30 3_137.4	137.4	20.4	250	0.59	1300	8950	10.2	315	0.37	1300	9600	
A 30 3_150.7	150.7	18.6	261	0.56	1170	9210	9.3	330	0.35	1300	9600	
A 30 3_161.4	161.4	17.3	270	0.54	1300	9410	8.7	340	0.34	1300	9600	
A 30 3_178.6	178.5	15.7	274	0.49	1210	9600	7.8	345	0.31	1300	9600	
A 30 3_198.5	198.5	14.1	280	0.45	1300	9600	7.1	350	0.28	1300	9600	
A 30 3_216.6	216.6	12.9	287	0.43	1240	9600	6.5	360	0.27	1300	9600	
A 30 3_244.3	244.3	11.5	295	0.39	1300	9600	5.7	370	0.24	1300	9600	
A 30 3_271.5	271.5	10.3	301	0.36	1280	9600	5.2	380	0.23	1300	9600	
A 30 3_314.6	314.5	8.9	309	0.32	1300	9600	4.5	390	0.20	1300	9600	
A 30 3_356.3	356.3	7.9	320	0.29	1300	9600	3.9	370	0.17	1300	9600	
A 30 3_400.8	400.8	7.0	320	0.26	1300	9600	3.5	360	0.14	1300	9600	



A 30

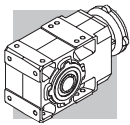

410 Nm

	i	n ₁ = 900 min ⁻¹					n ₁ = 500 min ⁻¹					
		n ₂ min ⁻¹	M _{n2} Nm	P _{n1} kW	R _{n1} N	R _{n2} N	n ₂ min ⁻¹	M _{n2} Nm	P _{n1} kW	R _{n1} N	R _{n2} N	
A 30 2_5.4	5.4	166	255	4.7	1660	3630	92	300	3.1	2200	4470	127
A 30 2_6.4	6.4	140	270	4.2	1630	3830	78	300	2.6	2200	4830	
A 30 2_7.0	7.0	128	284	4.1	1650	3920	71	300	2.4	2200	5040	
A 30 2_8.5	8.5	106	290	3.4	1810	4240	59	300	2.0	2200	5470	
A 30 2_9.3	9.3	97	300	3.2	1900	4380	54	300	1.8	2200	5710	
A 30 2_10.5	10.5	86	391	3.7	2200	4130	48	410	2.2	2200	5400	
A 30 2_11.8	11.8	76	300	2.6	2200	4880	42	300	1.4	2200	6320	
A 30 2_13.6	13.6	66	410	3.0	2200	4600	37	410	1.7	2200	6110	
A 30 2_16.3	16.3	55	410	2.5	2200	5044	31	410	1.4	2200	6650	
A 30 2_18.0	18.0	50	410	2.3	2200	5280	27.8	410	1.3	2200	6940	
A 30 2_20.5	20.5	44	410	2.0	2200	5630	24.3	410	1.1	2200	7360	
A 30 2_22.8	22.8	40	410	1.8	2200	5910	22.0	410	1.0	2200	7700	
A 30 2_26.5	26.5	34	410	1.5	2200	6340	18.8	410	0.86	2200	8230	
A 30 2_29.3	29.3	31	410	1.4	2200	6640	17.1	410	0.78	2200	8590	
A 30 2_33.4	33.4	26.9	410	1.2	2200	7040	15.0	410	0.68	2200	9080	
A 30 2_36.6	36.6	24.6	410	1.1	2200	7340	13.6	410	0.62	2200	9440	
A 30 2_39.3	39.3	22.9	410	1.0	2200	7560	12.7	410	0.58	2200	9600	
A 30 2_43.4	43.4	20.7	410	0.95	2200	7900	11.5	410	0.53	2200	9600	
A 30 2_48.3	48.3	18.6	410	0.85	2200	8270	10.4	410	0.47	2200	9600	
A 30 2_52.7	52.7	17.1	410	0.78	2200	8590	9.5	410	0.43	2200	9600	
A 30 2_59.4	59.4	15.1	400	0.67	2200	9090	8.4	400	0.37	2200	9600	
A 30 2_66.0	66.0	13.6	390	0.59	2200	9560	7.6	390	0.33	2200	9600	
A 30 2_76.5	76.5	11.8	350	0.46	2200	9600	6.5	350	0.25	2200	9600	
A 30 2_86.7	86.7	10.4	320	0.37	2200	9600	5.8	320	0.21	2200	9600	
A 30 2_97.5	97.5	9.2	300	0.31	2200	9600	5.1	300	0.17	2200	9600	
A 30 3_109.1	109.1	8.3	350	0.33	1300	9600	4.6	370	0.20	1300	9600	
A 30 3_120.5	120.5	7.5	354	0.30	1300	9600	4.2	410	0.20	1300	9600	
A 30 3_137.4	137.4	6.5	370	0.28	1300	9600	3.6	410	0.17	1300	9600	
A 30 3_150.7	150.7	6.0	381	0.26	1300	9600	3.3	410	0.16	1300	9600	
A 30 3_161.4	161.4	5.6	390	0.25	1300	9600	3.1	410	0.15	1300	9600	
A 30 3_178.6	178.5	5.0	400	0.23	1300	9600	2.8	410	0.13	1300	9600	
A 30 3_198.5	198.5	4.5	410	0.21	1300	9600	2.5	410	0.12	1300	9600	
A 30 3_216.6	216.6	4.2	410	0.20	1300	9600	2.3	410	0.11	1300	9600	
A 30 3_244.3	244.3	3.7	410	0.17	1300	9600	2.0	410	0.10	1300	9600	
A 30 3_271.5	271.5	3.3	410	0.16	1300	9600	1.8	410	0.09	1300	9600	
A 30 3_314.6	314.5	2.9	410	0.13	1300	9600	1.6	410	0.07	1300	9600	
A 30 3_356.3	356.3	2.5	380	0.11	1300	9600	1.4	380	0.06	1300	9600	
A 30 3_400.8	400.8	2.2	360	0.09	1300	9600	1.2	360	0.05	1300	9600	



A 35

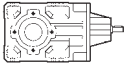

600 Nm

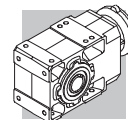
	i	n ₁ = 2800 min ⁻¹					n ₁ = 1400 min ⁻¹					
		n ₂ min ⁻¹	M _{n2} Nm	P _{n1} kW	R _{n1} N	R _{n2} N	n ₂ min ⁻¹	M _{n2} Nm	P _{n1} kW	R _{n1} N	R _{n2} N	
A 35 2_5.4	5.4	517	246	14.2	1420	4000	259	310	8.9	1790	5050	131
A 35 2_6.4	6.4	437	262	12.7	1420	4230	218	330	8.0	1790	5330	
A 35 2_7.0	7.0	399	278	12.3	1410	4320	199	350	7.8	1790	5440	
A 35 2_8.5	8.5	331	286	10.5	1450	4650	165	360	6.6	1830	5850	
A 35 2_9.3	9.3	301	302	10.1	1450	4760	150	380	6.4	1830	6000	
A 35 2_10.6	10.6	263	310	9.1	1440	5010	132	390	5.7	1830	6310	
A 35 2_11.8	11.8	238	317	8.4	1480	5200	119	400	5.3	1860	6550	
A 35 2_13.1	13.1	214	400	10.9	1630	4470	107	550	6.6	2100	5780	
A 35 2_15.5	15.5	181	430	10.0	1620	4670	90	570	5.7	2120	6190	
A 35 2_17.0	17.0	165	465	9.7	1620	4730	83	600	5.5	2130	6310	
A 35 2_20.4	20.4	137	500	8.4	1630	5080	69	600	4.6	2170	6930	
A 35 2_22.5	22.5	125	540	7.8	1660	5290	62	600	4.2	2200	7260	
A 35 2_25.7	25.7	109	585	7.1	1640	5540	55	600	3.6	2200	7740	
A 35 2_28.4	28.4	98	600	6.6	1660	5760	49	600	3.3	2200	8130	
A 35 2_33.2	33.2	84	600	5.6	910	6240	42	600	2.8	2200	8730	
A 35 2_36.6	36.6	76	600	5.1	1080	6560	38	600	2.6	2200	9140	
A 35 2_41.8	41.8	67	600	4.5	1140	7010	34	600	2.2	2200	9700	
A 35 2_45.8	45.8	61	600	4.1	1260	7330	31	600	2.0	2200	10100	
A 35 2_49.1	49.1	57	600	3.8	1260	7580	28.5	600	1.9	2200	10400	
A 35 2_54.3	54.3	52	600	3.4	1360	7950	25.8	600	1.7	2200	10900	
A 35 2_60.4	60.4	46	600	3.1	1470	8360	23.2	600	1.6	2200	11400	
A 35 2_65.8	65.8	43	600	2.8	1470	8700	21.3	600	1.4	2200	11800	
A 35 2_74.3	74.3	38	600	2.5	1560	9200	18.8	600	1.3	2200	12000	
A 35 2_82.5	82.5	34	600	2.3	1560	9650	17.0	600	1.1	2200	12000	
A 35 2_95.6	95.6	29.3	540	1.8	1860	10600	14.6	540	0.88	2200	12000	
A 35 3_105.5	105.5	26.5	430	1.3	550	12000	13.3	525	0.80	780	12000	
A 35 3_116.9	116.9	24.0	455	1.3	650	12000	12.0	560	0.77	870	12000	
A 35 3_136.3	136.3	20.5	470	1.1	870	12000	10.3	575	0.68	1110	12000	
A 35 3_150.6	150.6	18.6	495	1.1	900	12000	9.3	600	0.64	1160	12000	
A 35 3_171.8	171.8	16.3	505	0.95	960	12000	8.1	600	0.56	1250	12000	
A 35 3_188.3	188.3	14.9	525	0.90	990	12000	7.4	600	0.51	1300	12000	
A 35 3_201.8	201.8	13.9	525	0.84	1020	12000	6.9	600	0.48	1300	12000	
A 35 3_223.2	223.2	12.5	545	0.79	1050	12000	6.3	600	0.43	1300	12000	
A 35 3_248.1	248.1	11.3	565	0.73	1080	12000	5.6	600	0.39	1300	12000	
A 35 3_270.7	270.7	10.3	570	0.68	1110	12000	5.2	600	0.36	1300	12000	
A 35 3_305.4	305.4	9.2	585	0.62	1140	12000	4.6	600	0.32	1300	12000	
A 35 3_339.3	339.3	8.3	520	0.49	1210	12000	4.1	520	0.25	1300	12000	
A 35 3_393.2	393.2	7.1	465	0.38	1260	12000	3.6	465	0.19	1300	12000	



A 35

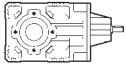

600 Nm

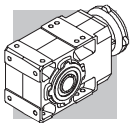
	i	n ₁ = 900 min ⁻¹					n ₁ = 500 min ⁻¹					
		n ₂ min ⁻¹	M _{n2} Nm	P _{n1} kW	R _{n1} N	R _{n2} N	n ₂ min ⁻¹	M _{n2} Nm	P _{n1} kW	R _{n1} N	R _{n2} N	
A 35 2_5.4	5.4	166	340	6.3	2150	5940	92	340	3.5	2200	7600	131
A 35 2_6.4	6.4	140	350	5.5	2190	6340	78	350	3.0	2200	8090	
A 35 2_7.0	7.0	128	370	5.3	2200	6490	71	370	2.9	2200	8290	
A 35 2_8.5	8.5	106	380	4.5	2200	6970	59	380	2.5	2200	8890	
A 35 2_9.3	9.3	97	400	4.3	2200	7160	54	400	2.4	2200	9140	
A 35 2_10.6	10.6	85	400	3.8	2200	7570	47	400	2.1	2200	9650	
A 35 2_11.8	11.8	76	400	3.4	2200	7910	42	400	1.9	2200	10100	
A 35 2_13.1	13.1	69	600	4.6	2200	6910	38	600	2.6	2200	9140	
A 35 2_15.5	15.5	58	600	3.9	2090	7510	32	600	2.2	2200	9860	
A 35 2_17.0	17.0	53	600	3.5	2200	7840	29.5	600	2.0	2200	10300	
A 35 2_20.4	20.4	44	600	2.9	2200	8560	24.5	600	1.6	2200	11100	
A 35 2_22.5	22.5	40	600	2.7	2200	8950	22.2	600	1.5	2200	11600	
A 35 2_25.7	25.7	35	600	2.3	2200	9500	19.5	600	1.3	2200	12000	
A 35 2_28.4	28.4	32	600	2.1	2200	9950	17.6	600	1.2	2200	12000	
A 35 2_33.2	33.2	27.1	600	1.8	2200	10700	15.1	600	1.0	2200	12000	
A 35 2_36.6	36.6	24.6	600	1.6	2200	11100	13.7	600	0.91	2200	12000	
A 35 2_41.8	41.8	21.5	600	1.4	2200	11800	12.0	600	0.80	2200	12000	
A 35 2_45.8	45.8	19.6	600	1.3	2200	12000	10.9	600	0.73	2200	12000	
A 35 2_49.1	49.1	18.3	600	1.2	2200	12000	10.2	600	0.68	2200	12000	
A 35 2_54.3	54.3	16.6	600	1.1	2200	12000	9.2	600	0.62	2200	12000	
A 35 2_60.4	60.4	14.9	600	1.0	2200	12000	8.3	600	0.55	2200	12000	
A 35 2_65.8	65.8	13.7	600	0.91	2200	12000	7.6	600	0.51	2200	12000	
A 35 2_74.3	74.3	12.1	600	0.81	2200	12000	6.7	600	0.45	2200	12000	
A 35 2_82.5	82.5	10.9	600	0.73	2200	12000	6.1	600	0.40	2200	12000	
A 35 2_95.6	95.6	9.4	540	0.57	2200	12000	5.2	540	0.31	2200	12000	
A 35 3_105.5	105.5	8.5	600	0.59	940	12000	4.7	600	0.33	1300	12000	
A 35 3_116.9	116.9	7.7	600	0.53	1230	12000	4.3	600	0.30	1300	12000	
A 35 3_136.3	136.3	6.6	600	0.46	1300	12000	3.7	600	0.25	1300	12000	
A 35 3_150.6	150.6	6.0	600	0.41	1300	12000	3.3	600	0.23	1300	12000	
A 35 3_171.8	171.8	5.2	600	0.36	1300	12000	2.9	600	0.20	1300	12000	
A 35 3_188.3	188.3	4.8	600	0.33	1300	12000	2.7	600	0.18	1300	12000	
A 35 3_201.8	201.8	4.5	600	0.31	1300	12000	2.5	600	0.17	1300	12000	
A 35 3_223.2	223.2	4.0	600	0.28	1300	12000	2.2	600	0.15	1300	12000	
A 35 3_248.1	248.1	3.6	600	0.25	1300	12000	2.0	600	0.14	1300	12000	
A 35 3_270.7	270.7	3.3	600	0.23	1300	12000	1.8	600	0.13	1300	12000	
A 35 3_305.4	305.4	2.9	600	0.20	1300	12000	1.6	600	0.11	1300	12000	
A 35 3_339.3	339.3	2.7	520	0.16	1300	12000	1.5	520	0.09	1300	12000	
A 35 3_393.2	393.2	2.3	465	0.12	1300	12000	1.3	465	0.07	1300	12000	



A 41

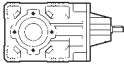

850 Nm

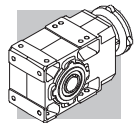
	i	n ₁ = 2800 min ⁻¹					n ₁ = 1400 min ⁻¹					
		n ₂ min ⁻¹	M _{n2} Nm	P _{n1} kW	R _{n1} N	R _{n2} N	n ₂ min ⁻¹	M _{n2} Nm	P _{n1} kW	R _{n1} N	R _{n2} N	
A 41 2_5.2	5.2	534	450	27	1790	4350	267	550	16.4	2450	5560	135
A 41 2_7.1	7.1	393	490	22	1890	4850	197	550	12.0	2670	6430	
A 41 2_8.3	8.3	336	510	19.1	1900	5140	168	550	10.3	2750	6920	
A 41 2_9.2	9.2	304	530	18.0	1980	5300	152	550	9.3	2860	7240	
A 41 2_10.1	10.1	276	435	13.4	2680	6030	138	535	8.2	3390	7650	
A 41 2_11.7	11.7	238	550	14.6	2050	5870	119	550	7.3	2950	8070	
A 41 2_13.8	13.8	204	480	10.9	2690	6680	102	585	6.6	3430	8510	
A 41 2_16.1	16.1	174	500	9.7	2700	7070	87	610	5.9	3430	9000	
A 41 2_17.8	17.8	158	515	9.0	2730	7310	79	630	5.5	3470	9300	
A 41 2_22.7	22.7	123	550	7.6	2730	7970	62	680	4.7	3460	10100	
A 41 2_28.3	28.3	99	595	6.6	2670	8570	49	730	4.0	3450	10900	
A 41 2_35.9	35.9	78	635	5.5	2590	9320	39	780	3.4	3410	11800	
A 41 2_45.1	45.1	62	680	4.7	2500	10100	31	830	2.9	3330	12800	
A 41 2_48.3	48.3	58	690	4.5	2430	10300	29.0	850	2.7	3200	13100	
A 41 2_53.1	53.1	53	700	4.1	2470	10700	26.3	850	2.5	3330	13700	
A 41 2_58.8	58.8	48	730	3.9	2390	11100	23.8	850	2.3	3460	14300	
A 41 2_64.2	64.2	44	740	3.6	2320	11500	21.8	850	2.1	3460	14800	
A 41 2_71.3	71.3	39	780	3.4	2120	11800	19.6	850	1.9	3470	15000	
A 41 2_79.2	79.2	35	800	3.1	1990	12300	17.7	800	1.6	3500	15000	
A 41 3_92.8	92.8	30	650	2.3	270	14000	15.1	800	1.4	430	15000	
A 41 3_115.9	115.9	24.2	800	2.2	310	14600	12.1	850	1.2	980	15000	
A 41 3_146.9	146.9	19.1	850	1.9	790	15000	9.5	850	0.93	1640	15000	
A 41 3_184.4	184.4	15.2	850	1.5	1290	15000	7.6	850	0.74	1770	15000	
A 41 3_197.5	197.5	14.2	850	1.4	1360	15000	7.1	850	0.69	1790	15000	
A 41 3_217.4	217.4	12.9	850	1.3	1390	15000	6.4	850	0.63	1820	15000	
A 41 3_240.6	240.6	11.6	850	1.1	1410	15000	5.8	850	0.57	1840	15000	
A 41 3_262.5	262.5	10.7	850	1.0	1430	15000	5.3	850	0.52	1860	15000	
A 41 3_291.7	291.7	9.6	850	0.94	1450	15000	4.8	850	0.47	1880	15000	
A 41 3_324.2	324.2	8.6	850	0.84	1470	15000	4.3	850	0.42	1900	15000	
A 41 3_376.8	376.8	7.4	850	0.73	1500	15000	3.7	850	0.36	1930	15000	



A 41

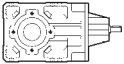

850 Nm

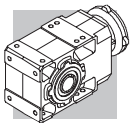
	i	n ₁ = 900 min ⁻¹					n ₁ = 500 min ⁻¹					
		n ₂ min ⁻¹	M _{n2} Nm	P _{n1} kW	R _{n1} N	R _{n2} N	n ₂ min ⁻¹	M _{n2} Nm	P _{n1} kW	R _{n1} N	R _{n2} N	
A 41 2_5.2	5.2	172	550	10.5	3140	6850	95	550	5.8	3500	8900	135
A 41 2_7.1	7.1	126	550	7.7	3360	7870	70	550	4.3	3500	10100	
A 41 2_8.3	8.3	108	550	6.6	3440	8430	60	550	3.7	3500	10800	
A 41 2_9.2	9.2	98	550	6.0	3500	8800	54	550	3.3	3500	11300	
A 41 2_10.1	10.1	89	610	6.0	3500	8920	49	730	4.0	3500	10900	
A 41 2_11.7	11.7	77	550	4.7	3500	9760	43	550	2.6	3500	12400	
A 41 2_13.8	13.8	65	670	4.9	3500	9900	36	800	3.2	3500	12100	
A 41 2_16.1	16.1	56	700	4.4	3500	10500	31	830	2.9	3500	12800	
A 41 2_17.8	17.8	51	720	4.1	3500	10800	28.1	850	2.7	3500	13300	
A 41 2_22.7	22.7	40	780	3.4	3500	11700	22.0	850	2.1	3500	14800	
A 41 2_28.3	28.3	32	830	2.9	3500	12700	17.7	850	1.7	3500	15000	
A 41 2_35.9	35.9	25.1	850	2.4	3500	14000	13.9	850	1.3	3500	15000	
A 41 2_45.1	45.1	20.0	850	1.9	3500	15000	11.1	850	1.1	3500	15000	
A 41 2_48.3	48.3	18.6	850	1.8	3500	15000	10.4	850	0.98	3500	15000	
A 41 2_53.1	53.1	16.9	850	1.6	3500	15000	9.4	850	0.89	3500	15000	
A 41 2_58.8	58.8	15.3	850	1.4	3500	15000	8.5	850	0.81	3500	15000	
A 41 2_64.2	64.2	14.0	850	1.3	3300	15000	7.8	850	0.74	3500	15000	
A 41 2_71.3	71.3	12.6	850	1.2	3500	15000	7.0	850	0.66	3500	15000	
A 41 2_79.2	79.2	11.4	800	1.0	3500	15000	6.3	800	0.56	3500	15000	
A 41 3_92.8	92.8	9.7	800	0.89	1080	15000	5.4	800	0.50	2110	15000	
A 41 3_115.9	115.9	7.8	850	0.76	1630	15000	4.3	850	0.42	2200	15000	
A 41 3_146.9	146.9	6.1	850	0.60	2020	15000	3.4	850	0.33	2200	15000	
A 41 3_184.4	184.4	4.9	850	0.48	2100	15000	2.7	850	0.27	2200	15000	
A 41 3_197.5	197.5	4.6	850	0.45	2120	15000	2.5	850	0.25	2200	15000	
A 41 3_217.4	217.4	4.1	850	0.40	2150	15000	2.3	850	0.22	2200	15000	
A 41 3_240.6	240.6	3.7	850	0.37	2170	15000	2.1	850	0.20	2200	15000	
A 41 3_262.5	262.5	3.4	850	0.34	2190	15000	1.9	850	0.19	2200	15000	
A 41 3_291.7	291.7	3.1	850	0.30	2200	15000	1.7	850	0.17	2200	15000	
A 41 3_324.2	324.2	2.8	850	0.27	2200	15000	1.5	850	0.15	2200	15000	
A 41 3_376.8	376.8	2.4	850	0.23	2200	15000	1.3	850	0.13	2200	15000	



A 50

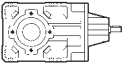

1500 Nm

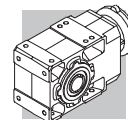
	i	n ₁ = 2800 min ⁻¹					n ₁ = 1400 min ⁻¹					
		n ₂ min ⁻¹	M _{n2} Nm	P _{n1} kW	R _{n1} N	R _{n2} N	n ₂ min ⁻¹	M _{n2} Nm	P _{n1} kW	R _{n1} N	R _{n2} N	
A 50 2_7.7	7.7	362	550	22	2300	7920	181	700	14.1	2890	9960	139
A 50 2_9.7	9.7	288	600	19.2	2330	8530	144	750	12.0	2950	10800	
A 50 2_13.1	13.1	214	600	14.3	2460	9600	107	750	8.9	3110	12100	
A 50 2_16.6	16.6	169	640	12.0	2490	10400	84	800	7.5	3150	13100	
A 50 2_20.9	20.9	134	640	9.5	2540	11400	67	800	6.0	3210	14400	
A 50 3_24.0	24.0	116	1150	15.4	1850	7020	58	1500	10.0	2100	8540	
A 50 3_26.4	26.4	106	1200	14.6	2100	7170	53	1500	9.1	2690	9100	
A 50 3_32.4	32.4	86	1290	12.8	1800	4630	43	1500	7.5	2760	10400	
A 50 3_35.6	35.6	79	1340	12.1	2080	7830	39	1500	6.8	3290	11000	
A 50 3_40.9	40.9	68	1415	11.1	1740	8130	34	1500	5.9	3220	11900	
A 50 3_45.0	45.0	62	1470	10.5	2030	8340	31	1500	5.4	3440	12600	
A 50 3_51.7	51.7	54	1500	9.4	1680	8970	27.1	1500	4.7	3400	13600	
A 50 3_56.8	56.8	49	1500	8.5	2150	9540	24.6	1500	4.3	3480	14400	
A 50 3_63.9	63.9	44	1500	7.6	1900	10300	21.9	1500	3.8	3450	15300	
A 50 3_70.2	70.2	40	1500	6.9	2350	10900	19.9	1500	3.4	3500	16100	
A 50 3_81.5	81.5	34	1500	5.9	2170	11900	17.2	1500	3.0	3500	17300	
A 50 3_89.5	89.5	31	1500	5.4	2590	12600	15.6	1500	2.7	3500	18200	
A 50 3_99.5	99.5	28.1	1500	4.9	2260	13400	14.1	1500	2.4	3500	19200	
A 50 3_109.4	109.4	25.6	1500	4.4	2680	14100	12.8	1500	2.2	3500	20000	
A 50 3_118.0	118.0	23.7	1500	4.1	2390	14700	11.9	1500	2.0	3500	20000	
A 50 3_129.7	129.7	21.6	1500	3.7	2720	15400	10.8	1500	1.9	3500	20000	
A 50 3_140.6	140.6	19.9	1500	3.4	2440	16100	10.0	1500	1.7	3500	20000	
A 50 3_154.6	154.6	18.1	1500	3.1	2730	16900	9.1	1500	1.6	3500	20000	
A 50 3_173.4	173.4	16.2	1500	2.8	2480	17900	8.1	1500	1.4	3500	20000	
A 50 3_190.6	190.6	14.7	1500	2.5	2740	18800	7.3	1500	1.3	3500	20000	
A 50 4_211.0	211.0	13.3	1500	2.3	1930	20000	6.6	1500	1.2	2200	20000	
A 50 4_232.0	232.0	12.1	1500	2.1	1970	20000	6.0	1500	1.1	2200	20000	
A 50 4_260.9	260.9	10.7	1500	1.9	2010	20000	5.4	1500	0.95	2200	20000	
A 50 4_286.8	286.8	9.8	1500	1.7	2040	20000	4.9	1500	0.86	2200	20000	
A 50 4_332.6	332.6	8.4	1500	1.5	2080	20000	4.2	1500	0.74	2200	20000	
A 50 4_365.6	365.6	7.7	1500	1.4	2100	20000	3.8	1500	0.68	2200	20000	
A 50 4_406.4	406.4	6.9	1500	1.2	2130	20000	3.4	1500	0.61	2200	20000	
A 50 4_446.8	446.8	6.3	1500	1.1	2140	20000	3.1	1500	0.55	2200	20000	
A 50 4_481.6	481.6	5.8	1500	1.0	2160	20000	2.9	1500	0.51	2200	20000	
A 50 4_529.5	529.5	5.3	1500	0.93	2170	20000	2.6	1500	0.47	2200	20000	
A 50 4_574.2	574.2	4.9	1500	0.86	2190	20000	2.4	1500	0.43	2200	20000	
A 50 4_631.2	631.2	4.4	1500	0.78	2200	20000	2.2	1500	0.39	2200	20000	
A 50 4_707.9	707.9	4.0	1500	0.70	2200	20000	2.0	1500	0.35	2200	20000	
A 50 4_778.2	778.2	3.6	1500	0.63	2200	20000	1.8	1500	0.32	2200	20000	



A 50

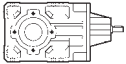

1500 Nm

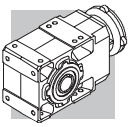
	i	n ₁ = 900 min ⁻¹					n ₁ = 500 min ⁻¹					
		n ₂ min ⁻¹	M _{n2} Nm	P _{n1} kW	R _{n1} N	R _{n2} N	n ₂ min ⁻¹	M _{n2} Nm	P _{n1} kW	R _{n1} N	R _{n2} N	
A 50 2_7.7	7.7	116	770	10.0	3430	11700	65	900	6.5	3500	14300	139
A 50 2_9.7	9.7	92	830	8.5	3490	12600	51	1000	5.7	3500	15300	
A 50 2_13.1	13.1	69	830	6.3	3500	14200	38	1000	4.2	3500	17300	
A 50 2_16.6	16.6	54	880	5.3	3500	15400	30	1000	3.4	3500	18900	
A 50 2_20.9	20.9	43	880	4.2	3500	16800	23.9	1000	2.7	3500	20000	
A 50 3_24.0	24.0	37	1500	6.5	3480	11300	20.8	1500	3.6	3500	15700	
A 50 3_26.4	26.4	34	1500	5.9	3500	12000	18.9	1500	3.3	3500	16500	
A 50 3_32.4	32.4	27.8	1500	4.8	3500	13400	15.4	1500	2.7	3500	18300	
A 50 3_35.6	35.6	25.3	1500	4.4	3500	14200	14.0	1500	2.4	3500	19200	
A 50 3_40.9	40.9	22.0	1500	3.8	3500	15300	12.2	1500	2.1	3500	20000	
A 50 3_45.0	45.0	20.0	1500	3.5	3500	16000	11.1	1500	1.9	3500	20000	
A 50 3_51.7	51.7	17.4	1500	3.0	3450	17200	9.7	1500	1.7	3500	20000	
A 50 3_56.8	56.8	15.8	1500	2.7	3500	18100	8.8	1500	1.5	3500	20000	
A 50 3_63.9	63.9	14.1	1500	2.4	3500	19200	7.8	1500	1.4	3500	20000	
A 50 3_70.2	70.2	12.8	1500	2.2	3500	20000	7.1	1500	1.2	3500	20000	
A 50 3_81.5	81.5	11.0	1500	1.9	3500	20000	6.1	1500	1.1	3500	20000	
A 50 3_89.5	89.5	10.1	1500	1.7	3500	20000	5.6	1500	0.96	3500	20000	
A 50 3_99.5	99.5	9.0	1500	1.6	3500	20000	5.0	1500	0.87	3500	20000	
A 50 3_109.4	109.4	8.2	1500	1.4	3500	20000	4.6	1500	0.79	3500	20000	
A 50 3_118.0	118.0	7.6	1500	1.3	3500	20000	4.2	1500	0.73	3500	20000	
A 50 3_129.7	129.7	6.9	1500	1.2	3500	20000	3.9	1500	0.67	3500	20000	
A 50 3_140.6	140.6	6.4	1500	1.1	3500	20000	3.6	1500	0.61	3500	20000	
A 50 3_154.6	154.6	5.8	1500	1.0	3500	20000	3.2	1500	0.56	3500	20000	
A 50 3_173.4	173.4	5.2	1500	0.90	3500	20000	2.9	1500	0.50	3500	20000	
A 50 3_190.6	190.6	4.7	1500	0.82	3500	20000	2.6	1500	0.45	3500	20000	
A 50 4_211.0	211.0	4.3	1500	0.75	2200	20000	2.4	1500	0.42	2200	20000	
A 50 4_232.0	232.0	3.9	1500	0.68	2200	20000	2.2	1500	0.38	2200	20000	
A 50 4_260.9	260.9	3.4	1500	0.61	2200	20000	1.9	1500	0.34	2200	20000	
A 50 4_286.8	286.8	3.1	1500	0.55	2200	20000	1.7	1500	0.31	2200	20000	
A 50 4_332.6	332.6	2.7	1500	0.48	2200	20000	1.5	1500	0.27	2200	20000	
A 50 4_365.6	365.6	2.5	1500	0.43	2200	20000	1.4	1500	0.24	2200	20000	
A 50 4_406.4	406.4	2.2	1500	0.39	2200	20000	1.2	1500	0.22	2200	20000	
A 50 4_446.8	446.8	2.0	1500	0.36	2200	20000	1.1	1500	0.20	2200	20000	
A 50 4_481.6	481.6	1.9	1500	0.33	2200	20000	1.0	1500	0.18	2200	20000	
A 50 4_529.5	529.5	1.7	1500	0.30	2200	20000	0.94	1500	0.17	2200	20000	
A 50 4_574.2	574.2	1.6	1500	0.28	2200	20000	0.87	1500	0.15	2200	20000	
A 50 4_631.2	631.2	1.4	1500	0.25	2200	20000	0.79	1500	0.14	2200	20000	
A 50 4_707.9	707.9	1.3	1500	0.22	2200	20000	0.71	1500	0.12	2200	20000	
A 50 4_778.2	778.2	1.2	1500	0.20	2200	20000	0.64	1500	0.11	2200	20000	



A 55

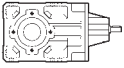

2000 Nm

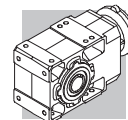
	i	n ₁ = 2800 min ⁻¹					n ₁ = 1400 min ⁻¹					
		n ₂ min ⁻¹	M _{n2} Nm	P _{n1} kW	R _{n1} N	R _{n2} N	n ₂ min ⁻¹	M _{n2} Nm	P _{n1} kW	R _{n1} N	R _{n2} N	
A 55 2_4.9	4.9	571	760	48	1320	15100	286	900	28	2150	18700	143
A 55 2_6.4	6.4	438	800	39	1950	16400	219	950	23	2860	20300	
A 55 2_8.5	8.5	329	800	30	2810	18000	165	950	17.5	3500	22200	
A 55 2_10.4	10.4	269	840	25	2900	19100	135	1000	15.1	3500	23600	
A 55 2_13.1	13.1	214	840	20	3230	20600	107	1000	11.9	3500	25500	
A 55 2_15.7	15.7	178	840	16.7	3440	21900	89	1000	9.9	3500	27000	
A 55 2_19.2	19.2	146	925	15.0	3160	23200	73	1100	8.9	3500	28600	
A 55 3_23.8	23.8	118	1600	22	2050	21000	59	1950	13.2	2640	26000	
A 55 3_29.9	29.9	94	1700	18.3	2110	22500	47	2000	10.8	2770	28200	
A 55 3_40.3	40.3	69	1850	14.8	2150	24800	35	2000	8.0	2930	30000	
A 55 3_51.0	51.0	55	2000	12.6	2170	26500	27.5	2000	6.3	3050	30000	
A 55 3_64.3	64.3	44	2000	10.0	2230	29000	21.8	2000	5.0	3110	30000	
A 55 3_79.5	79.5	35	2000	8.1	1040	30000	17.6	2000	4.1	2820	30000	
A 55 3_101.4	101.4	27.6	2000	6.4	1340	30000	13.8	2000	3.2	3130	30000	
A 55 3_123.9	123.9	22.6	2000	5.2	1450	30000	11.3	2000	2.6	3230	30000	
A 55 3_132.7	132.7	21.1	2000	4.9	1450	30000	10.6	2000	2.4	3240	30000	
A 55 3_146.8	146.8	19.1	2000	4.4	1610	30000	9.5	2000	2.2	3290	30000	
A 55 3_160.4	160.4	17.5	2000	4.0	1660	30000	8.7	2000	2.0	3300	30000	
A 55 3_175.0	175.0	16.0	2000	3.7	1660	30000	8.0	2000	1.8	3300	30000	
A 55 3_194.2	194.2	14.4	2000	3.3	1710	30000	7.2	2000	1.7	3310	30000	
A 55 4_208.1	208.1	13.5	1600	2.5	1890	30000	6.7	1950	1.5	2200	30000	
A 55 4_262.6	262.6	10.7	1650	2.1	1980	30000	5.3	2000	1.3	2200	30000	
A 55 4_324.7	324.7	8.6	1750	1.8	2030	30000	4.3	2000	1.0	2200	30000	
A 55 4_414.0	414.0	6.8	1850	1.5	2080	30000	3.4	2000	0.80	2200	30000	
A 55 4_505.9	505.9	5.5	1900	1.2	2120	30000	2.8	2000	0.65	2200	30000	
A 55 4_542.0	542.0	5.2	1900	1.2	2140	30000	2.6	2000	0.61	2200	30000	
A 55 4_599.5	599.5	4.7	1950	1.1	2150	30000	2.3	2000	0.55	2200	30000	
A 55 4_655.1	655.1	4.3	1950	1.0	2180	30000	2.1	2000	0.50	2200	30000	
A 55 4_714.7	714.7	3.9	1950	0.90	2200	30000	2.0	2000	0.46	2200	30000	
A 55 4_793.0	793.0	3.5	2000	0.83	2200	30000	1.8	2000	0.42	2200	30000	



A 55

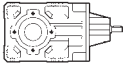

2000 Nm

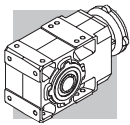
	i	n ₁ = 900 min ⁻¹					n ₁ = 500 min ⁻¹					
		n ₂ min ⁻¹	M _{n2} Nm	P _{n1} kW	R _{n1} N	R _{n2} N	n ₂ min ⁻¹	M _{n2} Nm	P _{n1} kW	R _{n1} N	R _{n2} N	
A 55 2_4.9	4.9	184	1000	20	2850	21400	102	1160	13.1	3500	25600	143
A 55 2_6.4	6.4	141	1060	16.6	3500	23200	78	1230	10.7	3500	27700	
A 55 2_8.5	8.5	106	1060	12.6	3500	25400	59	1230	8.1	3500	30000	
A 55 2_10.4	10.4	87	1120	10.8	3500	27000	48	1290	6.9	3500	30000	
A 55 2_13.1	13.1	69	1120	8.6	3500	29100	38	1290	5.5	3500	30000	
A 55 2_15.7	15.7	57	1120	7.2	3500	30000	32	1290	4.6	3500	30000	
A 55 2_19.2	19.2	47	1230	6.4	3500	30000	26.0	1420	4.1	3500	30000	
A 55 3_23.8	23.8	38	2000	8.7	3280	30000	21.0	2000	4.8	3500	30000	
A 55 3_29.9	29.9	30	2000	6.9	3450	30000	16.7	2000	3.8	3500	30000	
A 55 3_40.3	40.3	22.3	2000	5.1	3500	30000	12.4	2000	2.9	3500	30000	
A 55 3_51.0	51.0	17.6	2000	4.1	3500	30000	9.8	2000	2.3	3500	30000	
A 55 3_64.3	64.3	14.0	2000	3.2	3500	30000	7.8	2000	1.8	3500	30000	
A 55 3_79.5	79.5	11.3	2000	2.6	3500	30000	6.3	2000	1.4	3500	30000	
A 55 3_101.4	101.4	8.9	2000	2.0	3500	30000	4.9	2000	1.1	3500	30000	
A 55 3_123.9	123.9	7.3	2000	1.7	3500	30000	4.0	2000	0.93	3500	30000	
A 55 3_132.7	132.7	6.8	2000	1.6	3500	30000	3.8	2000	0.87	3500	30000	
A 55 3_146.8	146.8	6.1	2000	1.4	3500	30000	3.4	2000	0.78	3500	30000	
A 55 3_160.4	160.4	5.6	2000	1.3	3500	30000	3.1	2000	0.72	3500	30000	
A 55 3_175.0	175.0	5.1	2000	1.2	3500	30000	2.9	2000	0.66	3500	30000	
A 55 3_194.2	194.2	4.6	2000	1.1	3500	30000	2.6	2000	0.59	3500	30000	
A 55 4_208.1	208.1	4.3	2000	1.0	2200	30000	2.4	2000	0.57	2200	30000	
A 55 4_262.6	262.6	3.4	2000	0.81	2200	30000	1.9	2000	0.45	2200	30000	
A 55 4_324.7	324.7	2.8	2000	0.65	2200	30000	1.5	2000	0.36	2200	30000	
A 55 4_414.0	414.0	2.2	2000	0.51	2200	30000	1.2	2000	0.28	2200	30000	
A 55 4_505.9	505.9	1.8	2000	0.42	2200	30000	1.0	2000	0.23	2200	30000	
A 55 4_542.0	542.0	1.7	2000	0.39	2200	30000	0.92	2000	0.22	2200	30000	
A 55 4_599.5	599.5	1.5	2000	0.35	2200	30000	0.83	2000	0.20	2200	30000	
A 55 4_655.1	655.1	1.4	2000	0.32	2200	30000	0.76	2000	0.18	2200	30000	
A 55 4_714.7	714.7	1.3	2000	0.30	2200	30000	0.70	2000	0.16	2200	30000	
A 55 4_793.0	793.0	1.1	2000	0.27	2200	30000	0.63	2000	0.15	2200	30000	



A 60

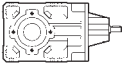

2800 Nm

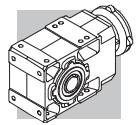
	i	n ₁ = 2800 min ⁻¹					n ₁ = 1400 min ⁻¹					
		n ₂ min ⁻¹	M _{n2} Nm	P _{n1} kW	R _{n1} N	R _{n2} N	n ₂ min ⁻¹	M _{n2} Nm	P _{n1} kW	R _{n1} N	R _{n2} N	
A 60 2_7.9	7.9	356	950	38	2770	22500	178	1200	24	3400	27700	147
A 60 2_10.3	10.3	271	950	29	2970	24600	136	1200	18.1	3740	30000	
A 60 2_12.7	12.7	220	1000	25	3020	26200	110	1250	15.3	3810	30000	
A 60 2_16.7	16.7	167	1050	19.6	3080	28600	84	1300	12.1	3910	30000	
A 60 2_20.6	20.6	136	1100	16.7	3100	30000	68	1400	10.6	3890	30000	
A 60 3_25.7	25.7	109	2760	35	2380	26900	54	2800	17.5	3800	30000	
A 60 3_27.9	27.9	101	2800	32	2780	27700	50	2800	16.2	3930	30000	
A 60 3_31.7	31.7	88	2800	29	2790	29000	44	2800	14.2	3940	30000	
A 60 3_34.3	34.3	82	2800	26	2920	30000	41	2800	13.2	4060	30000	
A 60 3_41.7	41.7	67	2800	22	2940	30000	34	2800	10.8	4090	30000	
A 60 3_45.2	45.2	62	2800	20	3060	30000	31	2800	10.0	4200	30000	
A 60 3_51.3	51.3	55	2800	17.6	3030	30000	27.3	2800	8.8	4180	30000	
A 60 3_55.6	55.6	50	2800	16.2	3140	30000	25.2	2800	8.1	4280	30000	
A 60 3_65.0	65.0	43	2800	13.9	3110	30000	21.5	2800	6.9	4260	30000	
A 60 3_70.4	70.4	40	2800	12.8	3210	30000	19.9	2800	6.4	4360	30000	
A 60 3_79.7	79.7	35	2800	11.3	3160	30000	17.6	2800	5.7	4310	30000	
A 60 3_86.4	86.4	32	2800	10.4	3260	30000	16.2	2800	5.2	4410	30000	
A 60 3_99.5	99.5	28.1	2800	9.1	3210	30000	14.1	2800	4.5	4360	30000	
A 60 3_107.8	107.8	26.0	2800	8.4	3300	30000	13.0	2800	4.2	4450	30000	
A 60 3_123.0	123.0	22.8	2800	7.3	3250	30000	11.4	2800	3.7	4400	30000	
A 60 3_133.3	133.3	21.0	2800	6.8	3340	30000	10.5	2800	3.4	4490	30000	
A 60 3_144.0	144.0	19.4	2800	6.3	3280	30000	9.7	2800	3.1	4420	30000	
A 60 3_156.0	156.0	17.9	2800	5.8	3360	30000	9.0	2800	2.9	4510	30000	
A 60 3_171.5	171.5	16.3	2800	5.3	3290	30000	8.2	2800	2.6	4430	30000	
A 60 3_185.8	185.8	15.1	2800	4.9	3370	30000	7.5	2800	2.4	4520	30000	
A 60 4_208.7	208.7	13.4	2800	4.4	2720	30000	6.7	2800	2.2	3500	30000	
A 60 4_226.1	226.1	12.4	2800	4.1	2770	30000	6.2	2800	2.0	3500	30000	
A 60 4_264.3	264.3	10.6	2800	3.5	2860	30000	5.3	2800	1.7	3500	30000	
A 60 4_286.3	286.3	9.8	2800	3.2	2900	30000	4.9	2800	1.6	3500	30000	
A 60 4_324.2	324.2	8.6	2800	2.8	2960	30000	4.3	2800	1.4	3500	30000	
A 60 4_351.2	351.2	8.0	2800	2.6	2990	30000	4.0	2800	1.3	3500	30000	
A 60 4_404.7	404.7	6.9	2800	2.3	3050	30000	3.5	2800	1.1	3500	30000	
A 60 4_438.4	438.4	6.4	2800	2.1	3070	30000	3.2	2800	1.1	3500	30000	
A 60 4_500.3	500.3	5.6	2800	1.8	3110	30000	2.8	2800	0.92	3500	30000	
A 60 4_542.0	542.0	5.2	2800	1.7	3140	30000	2.6	2800	0.85	3500	30000	
A 60 4_585.8	585.8	4.8	2800	1.6	3150	30000	2.4	2800	0.79	3500	30000	
A 60 4_634.6	634.6	4.4	2800	1.5	3170	30000	2.2	2800	0.73	3500	30000	
A 60 4_697.3	697.3	4.0	2800	1.3	3190	30000	2.0	2800	0.66	3500	30000	
A 60 4_755.4	755.4	3.7	2800	1.2	3210	30000	1.9	2800	0.61	3500	30000	

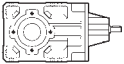

A 60

2800 Nm

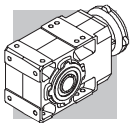

	i	n ₁ = 900 min ⁻¹					n ₁ = 500 min ⁻¹					
		n ₂ min ⁻¹	M _{n2} Nm	P _{n1} kW	R _{n1} N	R _{n2} N	n ₂ min ⁻¹	M _{n2} Nm	P _{n1} kW	R _{n1} N	R _{n2} N	
A 60 2_7.9	7.9	114	1300	16.6	4190	30000	64	1550	11.0	4700	30000	
A 60 2_10.3	10.3	87	1300	12.6	4470	30000	48	1550	8.4	4700	30000	
A 60 2_12.7	12.7	71	1400	11.0	4490	30000	39	1700	7.5	4700	30000	
A 60 2_16.7	16.7	54	1450	8.7	4610	30000	29.9	1700	5.7	4700	30000	
A 60 2_20.6	20.6	44	1550	7.5	4600	30000	24.3	1800	4.9	4700	30000	
A 60 3_25.7	25.7	35	2800	11.3	4680	30000	19.4	2800	6.3	4700	30000	
A 60 3_27.9	27.9	32	2800	10.4	4700	30000	18.0	2800	5.8	4700	30000	
A 60 3_31.7	31.7	28.4	2800	9.2	4700	30000	15.8	2800	5.1	4700	30000	
A 60 3_34.3	34.3	26.2	2800	8.5	4700	30000	14.6	2800	4.7	4700	30000	
A 60 3_41.7	41.7	21.6	2800	7.0	4700	30000	12.0	2800	3.9	4700	30000	
A 60 3_45.2	45.2	19.9	2800	6.4	4700	30000	11.1	2800	3.6	4700	30000	
A 60 3_51.3	51.3	17.5	2800	5.6	4700	30000	9.7	2800	3.1	4700	30000	
A 60 3_55.6	55.6	16.2	2800	5.2	4700	30000	9.0	2800	2.9	4700	30000	
A 60 3_65.0	65.0	13.8	2800	4.5	4700	30000	7.7	2800	2.5	4700	30000	
A 60 3_70.4	70.4	12.8	2800	4.1	4700	30000	7.1	2800	2.3	4700	30000	
A 60 3_79.7	79.7	11.3	2800	3.6	4700	30000	6.3	2800	2.0	4700	30000	
A 60 3_86.4	86.4	10.4	2800	3.4	4700	30000	5.8	2800	1.9	4700	30000	
A 60 3_99.5	99.5	9.0	2800	2.9	4700	30000	5.0	2800	1.6	4700	30000	
A 60 3_107.8	107.8	8.3	2800	2.7	4700	30000	4.6	2800	1.5	4700	30000	
A 60 3_123.0	123.0	7.3	2800	2.4	4700	30000	4.1	2800	1.3	4700	30000	
A 60 3_133.3	133.3	6.8	2800	2.2	4700	30000	3.8	2800	1.2	4700	30000	
A 60 3_144.0	144.0	6.2	2800	2.0	4700	30000	3.5	2800	1.1	4700	30000	
A 60 3_156.0	156.0	5.8	2800	1.9	4700	30000	3.2	2800	1.0	4700	30000	
A 60 3_171.5	171.5	5.2	2800	1.7	4700	30000	2.9	2800	0.94	4700	30000	
A 60 3_185.8	185.8	4.8	2800	1.6	4700	30000	2.7	2800	0.87	4700	30000	
A 60 4_208.7	208.7	4.3	2800	1.4	3500	30000	2.4	2800	0.79	3500	30000	
A 60 4_226.1	226.1	4.0	2800	1.3	3500	30000	2.2	2800	0.73	3500	30000	
A 60 4_264.3	264.3	3.4	2800	1.1	3500	30000	1.9	2800	0.62	3500	30000	
A 60 4_286.3	286.3	3.1	2800	1.0	3500	30000	1.7	2800	0.58	3500	30000	
A 60 4_324.2	324.2	2.8	2800	0.91	3500	30000	1.5	2800	0.51	3500	30000	
A 60 4_351.2	351.2	2.6	2800	0.84	3500	30000	1.4	2800	0.47	3500	30000	
A 60 4_404.7	404.7	2.2	2800	0.73	3500	30000	1.2	2800	0.41	3500	30000	
A 60 4_438.4	438.4	2.1	2800	0.68	3500	30000	1.1	2800	0.38	3500	30000	
A 60 4_500.3	500.3	1.8	2800	0.59	3500	30000	1.0	2800	0.33	3500	30000	
A 60 4_542.0	542.0	1.7	2800	0.55	3500	30000	0.92	2800	0.30	3500	30000	
A 60 4_585.8	585.8	1.5	2800	0.51	3500	30000	0.85	2800	0.28	3500	30000	
A 60 4_634.6	634.6	1.4	2800	0.47	3500	30000	0.79	2800	0.26	3500	30000	
A 60 4_697.3	697.3	1.3	2800	0.43	3500	30000	0.72	2800	0.24	3500	30000	
A 60 4_755.4	755.4	1.2	2800	0.39	3500	30000	0.66	2800	0.22	3500	30000	

147



A 70

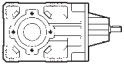

5000 Nm

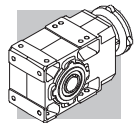
	i	n ₁ = 2800 min ⁻¹					n ₁ = 1400 min ⁻¹					
		n ₂ min ⁻¹	M _{n2} Nm	P _{n1} kW	R _{n1} N	R _{n2} N	n ₂ min ⁻¹	M _{n2} Nm	P _{n1} kW	R _{n1} N	R _{n2} N	
A 70 3_9.4	9.4	297	2300	79	1900	25900	148	2800	48	2550	31900	151
A 70 3_10.2	10.2	274	2400	76	2480	26400	137	3200	50	1480	31900	
A 70 3_12.1	12.1	232	2400	64	2420	28000	116	3200	43	1400	33900	
A 70 3_13.1	13.1	214	2600	64	2420	28400	107	3350	41	2100	34600	
A 70 3_15.4	15.4	182	2700	56	2100	29900	91	3350	35	2430	36700	
A 70 3_16.7	16.7	168	2850	55	2500	30400	84	3600	35	2590	37200	
A 70 3_19.7	19.7	142	2900	48	2030	32100	71	3700	30	1790	39300	
A 70 3_21.3	21.3	131	3000	45	2750	32900	66	4000	30	1830	39800	
A 70 3_23.5	23.5	119	3500	48	4930	32900	60	4300	30	6250	40500	
A 70 3_27.8	27.8	101	3450	40	4960	35100	50	4200	24	6300	43300	
A 70 3_30.1	30.1	93	3700	40	4970	35600	47	4550	24	6300	43900	
A 70 3_35.4	35.4	79	3650	33	5040	37900	40	4500	21	6370	46600	
A 70 3_38.4	38.4	73	3950	33	5040	38400	36	4850	20	6380	47300	
A 70 3_45.2	45.2	62	3900	28	5050	40800	31	4800	17.1	6400	50000	
A 70 3_49.0	49.0	57	4250	28	5050	41300	28.6	5000	16.4	6450	50000	
A 70 3_53.2	53.2	53	4100	25	5030	42900	26.3	5000	15.1	6380	50000	
A 70 3_57.7	57.7	49	4450	25	5030	43400	24.3	5000	14.0	6490	50000	
A 70 3_66.9	66.9	42	4350	21	5050	46000	20.9	5000	12.0	6480	50000	
A 70 3_72.5	72.5	39	4750	21	5040	46500	19.3	5000	11.1	6580	50000	
A 70 3_79.3	79.3	35	4600	18.7	5020	48400	17.6	5000	10.2	6520	50000	
A 70 3_85.9	85.9	33	4950	18.6	5030	49100	16.3	5000	9.4	6620	50000	
A 70 3_96.2	96.2	29.1	4850	16.2	5000	50000	14.6	5000	8.4	6570	50000	
A 70 3_104.2	104.2	26.9	5000	15.5	5060	50000	13.4	5000	7.7	6660	50000	
A 70 3_120.6	120.6	23.2	5000	13.4	5010	50000	11.6	5000	6.7	6610	50000	
A 70 3_130.7	130.7	21.4	5000	12.3	5100	50000	10.7	5000	6.2	6690	50000	
A 70 3_141.9	141.9	19.7	5000	11.4	5040	50000	9.9	5000	5.7	6640	50000	
A 70 3_153.7	153.7	18.2	3300	6.9	5410	50000	9.1	4050	4.2	6920	50000	
A 70 4_169.8	169.8	16.5	5000	9.7	1130	50000	8.2	5000	4.9	2520	50000	
A 70 4_183.9	183.9	15.2	5000	9.0	1450	50000	7.6	5000	4.5	2670	50000	
A 70 4_220.3	220.3	12.7	5000	7.5	1560	50000	6.4	5000	3.7	2710	50000	
A 70 4_238.6	238.6	11.7	5000	6.9	1860	50000	5.9	5000	3.5	2770	50000	
A 70 4_292.0	292.0	9.6	5000	5.6	1900	50000	4.8	5000	2.8	2790	50000	
A 70 4_316.4	316.4	8.9	5000	5.2	2110	50000	4.4	5000	2.6	2850	50000	
A 70 4_369.4	369.4	7.6	5000	4.5	2110	50000	3.8	5000	2.2	2840	50000	
A 70 4_400.2	400.2	7.0	5000	4.1	2160	50000	3.5	5000	2.1	2900	50000	
A 70 4_475.8	475.8	5.9	5000	3.5	2150	50000	2.9	5000	1.7	2890	50000	
A 70 4_515.4	515.4	5.4	5000	3.2	2200	50000	2.7	5000	1.6	2940	50000	
A 70 4_595.0	595.0	4.7	5000	2.8	2190	50000	2.4	5000	1.4	2920	50000	
A 70 4_644.6	644.6	4.3	5000	2.6	2230	50000	2.2	5000	1.3	2970	50000	
A 70 4_705.1	705.1	4.0	5000	2.3	2200	50000	2.0	5000	1.2	2940	50000	
A 70 4_763.9	763.9	3.7	5000	2.2	2250	50000	1.8	5000	1.1	2990	50000	
A 70 4_855.3	855.3	3.3	5000	1.9	2220	50000	1.6	5000	0.96	2960	50000	
A 70 4_926.5	926.5	3.0	5000	1.8	2270	50000	1.5	5000	0.89	3000	50000	
A 70 4_1072	1072	2.6	5000	1.5	2240	50000	1.3	5000	0.77	2970	50000	
A 70 4_1161	1161	2.4	5000	1.4	2280	50000	1.2	5000	0.71	3020	50000	
A 70 4_1242	1242	2.3	5000	1.3	2250	50000	1.1	5000	0.66	2980	50000	
A 70 4_1346	1346	2.1	5000	1.2	2290	50000	1.0	5000	0.61	3030	50000	
A 70 4_1583	1583	1.8	5000	1.0	2260	50000	0.88	5000	0.52	2990	50000	
A 70 4_1715	1715	1.6	5000	0.96	2300	50000	0.82	5000	0.48	3040	50000	



A 70

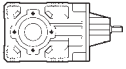

5000 Nm

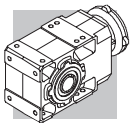
	i	n ₁ = 900 min ⁻¹					n ₁ = 500 min ⁻¹					
		n ₂ min ⁻¹	M _{n2} Nm	P _{n1} kW	R _{n1} N	R _{n2} N	n ₂ min ⁻¹	M _{n2} Nm	P _{n1} kW	R _{n1} N	R _{n2} N	
A 70 3_9.4	9.4	95	3000	33	4290	36900	53	3000	18.3	7000	45400	151
A 70 3_10.2	10.2	88	3250	33	4290	37400	49	3250	18.3	7000	46100	
A 70 3_12.1	12.1	75	3650	31	1620	38700	41	3650	17.4	6470	47900	
A 70 3_13.1	13.1	69	3950	31	1650	39200	38	3950	17.4	6500	48600	
A 70 3_15.4	15.4	58	3700	25	3510	42200	32	3700	13.8	7000	50000	
A 70 3_16.7	16.7	54	4000	25	3560	42800	30	4000	13.8	7000	50000	
A 70 3_19.7	19.7	46	3700	19.5	4910	46100	25.4	3700	10.8	7000	50000	
A 70 3_21.3	21.3	42	4000	19.4	4950	46800	23.5	4000	10.8	7000	50000	
A 70 3_23.5	23.5	38	4900	21.6	7000	46300	21.3	5000	12.2	7000	50000	
A 70 3_27.8	27.8	32	4800	17.9	7000	49400	18.0	5000	10.4	7000	50000	
A 70 3_30.1	30.1	29.9	5000	17.2	7000	50000	16.6	5000	9.6	7000	50000	
A 70 3_35.4	35.4	25.4	5000	14.6	7000	50000	14.1	5000	8.1	7000	50000	
A 70 3_38.4	38.4	23.4	5000	13.5	7000	50000	13.0	5000	7.5	7000	50000	
A 70 3_45.2	45.2	19.9	5000	11.4	7000	50000	11.1	5000	6.4	7000	50000	
A 70 3_49.0	49.0	18.4	5000	10.6	7000	50000	10.2	5000	5.9	7000	50000	
A 70 3_53.2	53.2	16.9	5000	9.7	7000	50000	9.4	5000	5.4	7000	50000	
A 70 3_57.7	57.7	15.6	5000	9.0	7000	50000	8.7	5000	5.0	7000	50000	
A 70 3_66.9	66.9	13.4	5000	7.7	7000	50000	7.5	5000	4.3	7000	50000	
A 70 3_72.5	72.5	12.4	5000	7.1	7000	50000	6.9	5000	4.0	7000	50000	
A 70 3_79.3	79.3	11.3	5000	6.5	7000	50000	6.3	5000	3.6	7000	50000	
A 70 3_85.9	85.9	10.5	5000	6.0	7000	50000	5.8	5000	3.3	7000	50000	
A 70 3_96.2	96.2	9.4	5000	5.4	7000	50000	5.2	5000	3.0	7000	50000	
A 70 3_104.2	104.2	8.6	5000	5.0	7000	50000	4.8	5000	2.8	7000	50000	
A 70 3_120.6	120.6	7.5	5000	4.3	7000	50000	4.1	5000	2.4	7000	50000	
A 70 3_130.7	130.7	6.9	5000	4.0	7000	50000	3.8	5000	2.2	7000	50000	
A 70 3_141.9	141.9	6.3	5000	3.7	7000	50000	3.5	5000	2.0	7000	50000	
A 70 3_153.7	153.7	5.9	4600	3.1	7000	50000	3.3	5000	1.9	7000	50000	
A 70 4_169.8	169.8	5.3	5000	3.1	3170	50000	2.9	5000	1.7	3500	50000	
A 70 4_183.9	183.9	4.9	5000	2.9	3240	50000	2.7	5000	1.6	3500	50000	
A 70 4_220.3	220.3	4.1	5000	2.4	3270	50000	2.3	5000	1.3	3500	50000	
A 70 4_238.6	238.6	3.8	5000	2.2	3340	50000	2.1	5000	1.2	3500	50000	
A 70 4_292.0	292.0	3.1	5000	1.8	3350	50000	1.7	5000	1.0	3500	50000	
A 70 4_316.4	316.4	2.8	5000	1.7	3410	50000	1.6	5000	0.93	3500	50000	
A 70 4_369.4	369.4	2.4	5000	1.4	3410	50000	1.4	5000	0.80	3500	50000	
A 70 4_400.2	400.2	2.2	5000	1.3	3460	50000	1.2	5000	0.74	3500	50000	
A 70 4_475.8	475.8	1.9	5000	1.1	3450	50000	1.1	5000	0.62	3500	50000	
A 70 4_515.4	515.4	1.7	5000	1.0	3500	50000	0.97	5000	0.57	3500	50000	
A 70 4_595.0	595.0	1.5	5000	0.89	3480	50000	0.84	5000	0.49	3500	50000	
A 70 4_644.6	644.6	1.4	5000	0.82	3500	50000	0.78	5000	0.46	3500	50000	
A 70 4_705.1	705.1	1.3	5000	0.75	3500	50000	0.71	5000	0.42	3500	50000	
A 70 4_763.9	763.9	1.2	5000	0.69	3500	50000	0.65	5000	0.39	3500	50000	
A 70 4_855.3	855.3	1.1	5000	0.62	3500	50000	0.58	5000	0.34	3500	50000	
A 70 4_926.5	926.5	0.97	5000	0.57	3500	50000	0.54	5000	0.32	3500	50000	
A 70 4_1072	1072	0.84	5000	0.49	3500	50000	0.47	5000	0.27	3500	50000	
A 70 4_1161	1161	0.77	5000	0.46	3500	50000	0.43	5000	0.25	3500	50000	
A 70 4_1242	1242	0.72	5000	0.43	3500	50000	0.40	5000	0.24	3500	50000	
A 70 4_1346	1346	0.67	5000	0.39	3500	50000	0.37	5000	0.22	3500	50000	
A 70 4_1583	1583	0.57	5000	0.33	3500	50000	0.32	5000	0.19	3500	50000	
A 70 4_1715	1715	0.52	5000	0.31	3500	50000	0.29	5000	0.17	3500	50000	

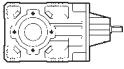

A 80

8000 Nm

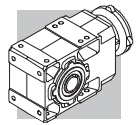

	i	n ₁ = 2800 min ⁻¹					n ₁ = 1400 min ⁻¹					
		n ₂ min ⁻¹	M _{n2} Nm	P _{n1} kW	R _{n1} N	R _{n2} N	n ₂ min ⁻¹	M _{n2} Nm	P _{n1} kW	R _{n1} N	R _{n2} N	
A 80 3_9.8	9.8	285	3100	102	—	26300	142	3900	64	—	32100	154
A 80 3_10.7	10.7	263	3450	104	—	26300	131	4300	65	—	32300	
A 80 3_12.3	12.3	228	3450	91	—	27700	114	4300	56	—	34000	
A 80 3_13.3	13.3	211	3450	84	1150	28700	105	4300	52	1150	35200	
A 80 3_15.5	15.5	181	3300	69	1560	30600	91	4100	43	1730	37600	
A 80 3_16.7	16.7	167	3600	69	1440	30900	84	4500	43	1460	37900	
A 80 3_19.3	19.3	145	3500	58	1870	32800	72	4400	37	1880	40200	
A 80 3_20.9	20.9	134	3840	59	1670	33100	67	4800	37	1740	40600	
A 80 3_22.6	22.6	124	5050	72	4500	31200	62	6250	45	5830	38400	
A 80 3_24.5	24.5	114	5500	72	4470	31300	57	6750	44	5840	38600	
A 80 3_28.2	28.2	99	5350	61	4700	33500	50	6600	38	5960	41200	
A 80 3_30.6	30.6	92	5250	55	4840	34900	46	6450	34	6140	43000	
A 80 3_35.5	35.5	79	5700	52	4700	36000	39	7000	32	6000	44300	
A 80 3_38.5	38.5	73	6150	51	4720	36200	36	7600	32	6000	44500	
A 80 3_44.5	44.5	63	6050	44	4790	38600	31	7450	27	6070	47500	
A 80 3_48.2	48.2	58	6550	44	4790	38800	29.1	8000	27	6090	47900	
A 80 3_55.2	55.2	51	6400	37	4710	41300	25.4	7900	23	6050	50800	
A 80 3_59.8	59.8	47	6950	37	4690	41500	23.4	8000	22	6170	52300	
A 80 3_66.8	66.8	42	6800	33	4670	43700	21.0	8000	19.3	6150	54600	
A 80 3_72.4	72.4	39	7350	33	4680	44000	19.3	8000	17.8	6280	56500	
A 80 3_82.3	82.3	34	7200	28	4570	46600	17.0	8000	15.7	6230	59300	
A 80 3_89.2	89.2	31	7800	28	4570	46900	15.7	8000	14.5	6350	61400	
A 80 3_96.0	96.0	29.2	7500	25	4410	48900	14.6	8000	13.4	6260	63000	
A 80 3_104.0	104.0	26.9	8000	25	4500	49500	13.5	8000	12.4	6380	65000	
A 80 3_116.0	116.0	24.1	7950	22	4230	51700	12.1	8000	11.1	6300	65000	
A 80 3_125.6	125.6	22.3	8000	21	4630	53400	11.1	8000	10.3	6420	65000	
A 80 3_144.7	144.7	19.3	8000	17.8	4320	56400	9.7	8000	8.9	6350	65000	
A 80 3_156.8	156.8	17.9	8000	16.4	4750	58300	8.9	8000	8.2	6460	65000	
A 80 4_171.3	171.3	16.3	8000	15.4	—	65000	8.2	8000	7.7	1230	65000	
A 80 4_214.7	214.7	13.0	8000	12.3	—	65000	6.5	8000	6.1	1400	65000	
A 80 4_232.6	232.6	12.0	8000	11.3	—	65000	6.0	8000	5.7	1810	65000	
A 80 4_277.3	277.3	10.1	8000	9.5	540	65000	5.0	8000	4.8	1930	65000	
A 80 4_300.4	300.4	9.3	8000	8.8	900	65000	4.7	8000	4.4	2290	65000	
A 80 4_354.0	354.0	7.9	8000	7.4	800	65000	4.0	8000	3.7	2190	65000	
A 80 4_383.5	383.5	7.3	8000	6.9	1140	65000	3.7	8000	3.4	2530	65000	
A 80 4_442.1	442.1	6.3	8000	6.0	1040	65000	3.2	8000	3.0	2430	65000	
A 80 4_478.9	478.9	5.8	8000	5.5	1370	65000	2.9	8000	2.8	2670	65000	
A 80 4_560.5	560.5	5.0	8000	4.7	1240	65000	2.5	8000	2.4	2630	65000	
A 80 4_607.2	607.2	4.6	8000	4.3	1550	65000	2.3	8000	2.2	2720	65000	
A 80 4_703.5	703.5	4.0	8000	3.7	1440	65000	2.0	8000	1.9	2690	65000	
A 80 4_762.1	762.1	3.7	8000	3.5	1730	65000	1.8	8000	1.7	2760	65000	
A 80 4_829.5	829.5	3.4	8000	3.2	1530	65000	1.7	8000	1.6	2720	65000	
A 80 4_898.7	898.7	3.1	8000	2.9	1820	65000	1.6	8000	1.5	2780	65000	
A 80 4_1001	1001	2.8	8000	2.6	1620	65000	1.4	8000	1.3	2740	65000	
A 80 4_1085	1085	2.6	8000	2.4	1900	65000	1.3	8000	1.2	2800	65000	
A 80 4_1237	1237	2.3	8000	2.1	1660	65000	1.1	8000	1.1	2750	65000	
A 80 4_1340	1340	2.1	8000	2.0	1940	65000	1.0	8000	0.98	2810	65000	
A 80 4_1438	1438	1.9	8000	1.8	1730	65000	0.97	8000	0.92	2770	65000	
A 80 4_1558	1558	1.8	8000	1.7	2000	65000	0.90	8000	0.85	2830	65000	

(—) Interpellare il ns. servizio tecnico comunicando i dati relativi al carico radiale (senso di rotazione, orientamento, posizione)
 (—) Contact our technical service department advising radial load data (rotation direction, orientation, position)
 (—) Nehmen Sie bitte Kontakt mit unserem Applikationsdienst und Querkraftsdaten angeben (Drehrichtung, Orientierung, Anordnung)
 (—) Consulter notre service technique en donnant les dÉtails concernant la charge radiale (sens de rotation, indexage, position)

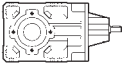

A 80

8000 Nm

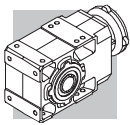

	i	n ₁ = 900 min ⁻¹					n ₁ = 500 min ⁻¹					
		n ₂ min ⁻¹	M _{n2} Nm	P _{n1} kW	R _{n1} N	R _{n2} N	n ₂ min ⁻¹	M _{n2} Nm	P _{n1} kW	R _{n1} N	R _{n2} N	
A 80 3_9.8	9.8	92	4450	47	—	36700	51	5300	31	—	43800	154
A 80 3_10.7	10.7	84	4900	48	—	36900	47	5850	32	—	44000	
A 80 3_12.3	12.3	73	4900	41	—	38900	41	5850	27	—	46400	
A 80 3_13.3	13.3	68	4900	38	1360	40200	38	5850	25	1600	47900	
A 80 3_15.5	15.5	58	4650	31	2130	43000	32	5550	21	2530	51300	
A 80 3_16.7	16.7	54	5100	32	1840	43400	29.9	6100	21	2120	51700	
A 80 3_19.3	19.3	47	5000	27	2260	46000	25.9	6000	17.9	2530	54800	
A 80 3_20.9	20.9	43	5470	27	2030	46400	23.9	6500	17.9	2530	55400	
A 80 3_22.6	22.6	40	7100	33	6810	43900	22.1	8000	20.4	7000	53400	
A 80 3_24.5	24.5	37	7700	33	6800	44100	20.4	8000	18.8	7000	55300	
A 80 3_28.2	28.2	32	7550	28	6940	47000	17.7	8000	16.3	7000	58400	
A 80 3_30.6	30.6	29.4	7400	25	7000	49000	16.4	8000	15.1	7000	60400	
A 80 3_35.5	35.5	25.3	8000	23	6980	50600	14.1	8000	13.0	7000	63900	
A 80 3_38.5	38.5	23.4	8000	22	7000	52400	13.0	8000	12.0	7000	65000	
A 80 3_44.5	44.5	20.2	8000	18.6	7000	55400	11.2	8000	10.3	7000	65000	
A 80 3_48.2	48.2	18.7	8000	17.2	7000	57300	10.4	8000	9.6	7000	65000	
A 80 3_55.2	55.2	16.3	8000	15.0	7000	60300	9.1	8000	8.3	7000	65000	
A 80 3_59.8	59.8	15.1	8000	13.9	7000	62300	8.4	8000	7.7	7000	65000	
A 80 3_66.8	66.8	13.5	8000	12.4	7000	65000	7.5	8000	6.9	7000	65000	
A 80 3_72.4	72.4	12.4	8000	11.4	7000	65000	6.9	8000	6.4	7000	65000	
A 80 3_82.3	82.3	10.9	8000	10.1	7000	65000	6.1	8000	5.6	7000	65000	
A 80 3_89.2	89.2	10.1	8000	9.3	7000	65000	5.6	8000	5.2	7000	65000	
A 80 3_96.0	96.0	9.4	8000	8.6	7000	65000	5.2	8000	4.8	7000	65000	
A 80 3_104.0	104.0	8.7	8000	8.0	7000	65000	4.8	8000	4.4	7000	65000	
A 80 3_116.0	116.0	7.8	8000	7.1	7000	65000	4.3	8000	4.0	7000	65000	
A 80 3_125.6	125.6	7.2	8000	6.6	7000	65000	4.0	8000	3.7	7000	65000	
A 80 3_144.7	144.7	6.2	8000	5.7	7000	65000	3.5	8000	3.2	7000	65000	
A 80 3_156.8	156.8	5.7	8000	5.3	7000	65000	3.2	8000	2.9	7000	65000	
A 80 4_171.3	171.3	5.3	8000	4.9	2300	65000	2.9	8000	2.7	3500	65000	
A 80 4_214.7	214.7	4.2	8000	3.9	2470	65000	2.3	8000	2.2	3500	65000	
A 80 4_232.6	232.6	3.9	8000	3.6	2870	65000	2.1	8000	2.0	3500	65000	
A 80 4_277.3	277.3	3.2	8000	3.1	3000	65000	1.8	8000	1.7	3500	65000	
A 80 4_300.4	300.4	3.0	8000	2.8	3120	65000	1.7	8000	1.6	3500	65000	
A 80 4_354.0	354.0	2.5	8000	2.4	3100	65000	1.4	8000	1.3	3500	65000	
A 80 4_383.5	383.5	2.3	8000	2.2	3180	65000	1.3	8000	1.2	3500	65000	
A 80 4_442.1	442.1	2.0	8000	1.9	3160	65000	1.1	8000	1.1	3500	65000	
A 80 4_478.9	478.9	1.9	8000	1.8	3230	65000	1.0	8000	0.98	3500	65000	
A 80 4_560.5	560.5	1.6	8000	1.5	3210	65000	0.89	8000	0.84	3500	65000	
A 80 4_607.2	607.2	1.5	8000	1.4	3280	65000	0.82	8000	0.78	3500	65000	
A 80 4_703.5	703.5	1.3	8000	1.2	3260	65000	0.71	8000	0.67	3500	65000	
A 80 4_762.1	762.1	1.2	8000	1.1	3320	65000	0.66	8000	0.62	3500	65000	
A 80 4_829.5	829.5	1.1	8000	1.0	3280	65000	0.60	8000	0.57	3500	65000	
A 80 4_898.7	898.7	1.0	8000	0.94	3340	65000	0.56	8000	0.52	3500	65000	
A 80 4_1001	1001	0.90	8000	0.85	3300	65000	0.50	8000	0.47	3500	65000	
A 80 4_1085	1085	0.83	8000	0.78	3360	65000	0.46	8000	0.43	3500	65000	
A 80 4_1237	1237	0.73	8000	0.68	3310	65000	0.40	8000	0.38	3500	65000	
A 80 4_1340	1340	0.67	8000	0.63	3370	65000	0.37	8000	0.35	3500	65000	
A 80 4_1438	1438	0.63	8000	0.59	3330	65000	0.35	8000	0.33	3500	65000	
A 80 4_1558	1558	0.58	8000	0.54	3390	65000	0.32	8000	0.30	3500	65000	

(—) Interpellare il ns. servizio tecnico comunicando i dati relativi al carico radiale (senso di rotazione, orientamento, posizione)
 (—) Contact our technical service department advising radial load data (rotation direction, orientation, position)
 (—) Nehmen Sie bitte Kontakt mit unserem Applikationsdienst und Querkräftsdaten angeben (Drehrichtung, Orientierung, Anordnung)
 (—) Consulter notre service technique en donnant les dÉtails concernant la charge radiale (sens de rotation, indexage, position)

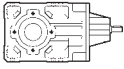

A 90

14000 Nm

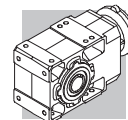

	i	n ₁ = 2800 min ⁻¹					n ₁ = 1400 min ⁻¹					
		n ₂ min ⁻¹	M _{n2} Nm	P _{n1} kW	R _{n1} N	R _{n2} N	n ₂ min ⁻¹	M _{n2} Nm	P _{n1} kW	R _{n1} N	R _{n2} N	
A 90 3_9.7	9.7	289	7800	260	2440	27600	145	9050	151	5520	35000	157
A 90 3_10.5	10.5	267	8350	257	2620	27700	134	9800	151	5530	34900	
A 90 3_12.6	12.6	221	8500	217	2700	29800	111	10450	133	4790	36700	
A 90 3_13.7	13.7	204	8050	189	4670	31800	102	11150	131	5060	36900	
A 90 3_15.6	15.6	180	8900	184	3240	32000	90	10950	113	5410	39400	
A 90 3_16.9	16.9	166	9650	184	3230	31900	83	11850	113	5440	39300	
A 90 3_19.4	19.4	144	9400	156	3160	34300	72	11550	96	5350	42300	
A 90 3_21.0	21.0	133	10150	156	3210	34300	67	12400	95	5510	42400	
A 90 3_22.3	22.3	126	9850	143	9660	35700	63	12150	88	12200	43900	
A 90 3_24.1	24.1	116	10700	143	9660	35500	58	13150	88	12200	43800	
A 90 3_29.1	29.1	96	10550	117	9800	38900	48	13000	72	12400	47900	
A 90 3_31.5	31.5	89	11450	117	9800	38800	44	14000	72	12400	47900	
A 90 3_35.8	35.8	78	11150	100	9910	41600	39	13750	62	12500	51100	
A 90 3_38.8	38.8	72	12100	100	9900	41500	36	14000	58	12700	52700	
A 90 3_44.6	44.6	63	11800	85	9920	44600	31	14000	51	12700	56000	
A 90 3_48.3	48.3	58	12800	85	9920	44500	29.0	14000	47	12800	58000	
A 90 3_55.0	55.0	51	12550	73	9960	47500	25.4	14000	41	12800	61400	
A 90 3_59.6	59.6	47	13550	73	9970	47500	23.5	14000	38	13000	63500	
A 90 3_68.8	68.8	41	13350	63	9960	50900	20.4	14000	33	13000	67400	
A 90 3_74.5	74.5	38	14000	61	10000	51700	18.8	14000	30	13100	69700	
A 90 3_80.4	80.4	35	13900	56	9920	53500	17.4	14000	28	13000	71900	
A 90 3_87.1	87.1	32	14000	52	10100	55500	16.1	14000	26	13200	74300	
A 90 3_98.6	98.6	28.4	14000	46	9990	58500	14.2	14000	23	13100	75000	
A 90 3_106.8	106.8	26.2	14000	42	10100	60600	13.1	14000	21	13300	75000	
A 90 3_116.9	116.9	24.0	14000	39	10100	63000	12.0	14000	19.3	13200	75000	
A 90 3_126.6	126.6	22.1	10650	27	10600	71400	11.1	13150	16.7	13400	75000	
A 90 3_139.4	139.4	20.1	10350	24	10600	74500	10.0	12750	14.7	13400	75000	
A 90 3_151.0	151.0	18.5	11200	24	10600	75000	9.3	13800	14.7	13400	75000	
A 90 4_166.1	166.1	16.9	14000	28	—	75000	8.4	14000	13.9	—	75000	
A 90 4_180.0	180.0	15.6	14000	26	—	75000	7.8	14000	12.8	—	75000	
A 90 4_209.0	209.0	13.4	14000	22	—	75000	6.7	14000	11.0	—	75000	
A 90 4_226.4	226.4	12.4	14000	20	—	75000	6.2	14000	10.2	—	75000	
A 90 4_281.4	281.4	9.9	14000	16.4	—	75000	5.0	14000	8.2	—	75000	
A 90 4_304.9	304.9	9.2	14000	15.1	—	75000	4.6	14000	7.6	—	75000	
A 90 4_355.8	355.8	7.9	14000	13.0	—	75000	3.9	14000	6.5	—	75000	
A 90 4_385.4	385.4	7.3	14000	12.0	—	75000	3.6	14000	6.0	680	75000	
A 90 4_449.2	449.2	6.2	14000	10.3	—	75000	3.1	14000	5.1	—	75000	
A 90 4_486.6	486.6	5.8	14000	9.5	—	75000	2.9	14000	4.7	950	75000	
A 90 4_555.3	555.3	5.0	14000	8.3	—	75000	2.5	14000	4.2	740	75000	
A 90 4_601.6	601.6	4.7	14000	7.7	—	75000	2.3	14000	3.8	1200	75000	
A 90 4_707.9	707.9	4.0	14000	6.5	—	75000	2.0	14000	3.3	1050	75000	
A 90 4_766.9	766.9	3.7	14000	6.0	—	75000	1.8	14000	3.0	1490	75000	
A 90 4_865.1	865.1	3.2	14000	5.3	—	75000	1.6	14000	2.7	1170	75000	
A 90 4_937.2	937.2	3.0	14000	4.9	—	75000	1.5	14000	2.5	1590	75000	
A 90 4_1025	1025	2.7	14000	4.5	—	75000	1.4	14000	2.2	1330	75000	
A 90 4_1111	1111	2.5	14000	4.2	—	75000	1.3	14000	2.1	1740	75000	
A 90 4_1222	1222	2.3	14000	3.8	—	75000	1.1	14000	1.9	1380	75000	
A 90 4_1324	1324	2.1	14000	3.5	—	75000	1.1	14000	1.7	1790	75000	
A 90 4_1507	1507	1.9	14000	3.1	—	75000	0.93	14000	1.5	1440	75000	
A 90 4_1632	1632	1.7	14000	2.8	—	75000	0.86	14000	1.4	1840	75000	

(—) Interpellare il ns. servizio tecnico comunicando i dati relativi al carico radiale (senso di rotazione, orientamento, posizione)
 (—) Contact our technical service department advising radial load data (rotation direction, orientation, position)
 (—) Nehmen Sie bitte Kontakt mit unserem Applikationsdienst und Querkraftsdaten angeben (Drehrichtung, Orientierung, Anordnung)
 (—) Consulter notre service technique en donnant les dÉtails concernant la charge radiale (sens de rotation, indexage, position)

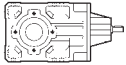

A 90

14000 Nm

	i	n ₁ = 900 min ⁻¹					n ₁ = 500 min ⁻¹					
		n ₂ min ⁻¹	M _{n2} Nm	P _{n1} kW	R _{n1} N	R _{n2} N	n ₂ min ⁻¹	M _{n2} Nm	P _{n1} kW	R _{n1} N	R _{n2} N	
A 90 3_9.7	9.7	93	9050	97	9800	42300	52	9050	54	15000	53700	157
A 90 3_10.5	10.5	86	9800	97	9810	42500	48	9800	54	15000	54200	
A 90 3_12.6	12.6	71	11800	97	6720	42100	40	11800	54	13500	54500	
A 90 3_13.7	13.7	66	12750	96	6770	42100	37	12800	54	13500	54600	
A 90 3_15.6	15.6	58	11550	77	8730	46700	32	11550	43	15000	59900	
A 90 3_16.9	16.9	53	12500	77	8750	46800	29.6	12500	43	15000	60300	
A 90 3_19.4	19.4	46	11550	62	9630	51400	25.8	11550	34	15000	65400	
A 90 3_21.0	21.0	43	12400	61	9790	51700	23.8	12400	34	15000	66100	
A 90 3_22.3	22.3	40	13850	64	14200	50200	22.5	14000	36	15000	64700	
A 90 3_24.1	24.1	37	14000	60	14400	51900	20.7	14000	33	15000	66900	
A 90 3_29.1	29.1	31	14000	50	14600	56200	17.2	14000	28	15000	72100	
A 90 3_31.5	31.5	28.6	14000	46	14800	58400	15.9	14000	26	15000	74700	
A 90 3_35.8	35.8	25.1	14000	40	14900	61700	14.0	14000	23	15000	75000	
A 90 3_38.8	38.8	23.2	14000	37	15000	63900	12.9	14000	21	15000	75000	
A 90 3_44.6	44.6	20.2	14000	33	15000	67700	11.2	14000	18.1	15000	75000	
A 90 3_48.3	48.3	18.6	14000	30	15000	70000	10.4	14000	16.7	15000	75000	
A 90 3_55.0	55.0	16.4	14000	26	15000	73800	9.1	14000	14.6	15000	75000	
A 90 3_59.6	59.6	15.1	14000	24	15000	75000	8.4	14000	13.5	15000	75000	
A 90 3_68.8	68.8	13.1	14000	21	15000	75000	7.3	14000	11.7	15000	75000	
A 90 3_74.5	74.5	12.1	14000	19.5	15000	75000	6.7	14000	10.8	15000	75000	
A 90 3_80.4	80.4	11.2	14000	18.0	15000	75000	6.2	14000	10.0	15000	75000	
A 90 3_87.1	87.1	10.3	14000	16.7	15000	75000	5.7	14000	9.3	15000	75000	
A 90 3_98.6	98.6	9.1	14000	14.7	15000	75000	5.1	14000	8.2	15000	75000	
A 90 3_106.8	106.8	8.4	14000	13.6	15000	75000	4.7	14000	7.5	15000	75000	
A 90 3_116.9	116.9	7.7	14000	12.4	15000	75000	4.3	14000	6.9	15000	75000	
A 90 3_126.6	126.6	7.1	14000	11.4	15000	75000	3.9	14000	6.4	15000	75000	
A 90 3_139.4	139.4	6.5	14000	10.4	15000	75000	3.6	14000	5.8	15000	75000	
A 90 3_151.0	151.0	6.0	14000	9.6	15000	75000	3.3	14000	5.3	15000	75000	
A 90 4_166.1	166.1	5.4	14000	8.9	—	75000	3.0	14000	5.0	700	75000	
A 90 4_180.0	180.0	5.0	14000	8.2	—	75000	2.8	14000	4.6	1400	75000	
A 90 4_209.0	209.0	4.3	14000	7.1	—	75000	2.4	14000	3.9	1500	75000	
A 90 4_226.4	226.4	4.0	14000	6.5	500	75000	2.2	14000	3.6	2100	75000	
A 90 4_281.4	281.4	3.2	14000	5.3	690	75000	1.8	14000	2.9	2300	75000	
A 90 4_304.9	304.9	3.0	14000	4.9	1230	75000	1.6	14000	2.7	2900	75000	
A 90 4_355.8	355.8	2.5	14000	4.2	1240	75000	1.4	14000	2.3	2900	75000	
A 90 4_385.4	385.4	2.3	14000	3.8	1750	75000	1.3	14000	2.1	3400	75000	
A 90 4_449.2	449.2	2.0	14000	3.3	1540	75000	1.1	14000	1.8	3200	75000	
A 90 4_486.6	486.6	1.8	14000	3.0	2020	75000	1.0	14000	1.7	3500	75000	
A 90 4_555.3	555.3	1.6	14000	2.7	1810	75000	0.90	14000	1.5	3500	75000	
A 90 4_601.6	601.6	1.5	14000	2.5	2270	75000	0.83	14000	1.4	3500	75000	
A 90 4_707.9	707.9	1.3	14000	2.1	2120	75000	0.71	14000	1.2	3500	75000	
A 90 4_766.9	766.9	1.2	14000	1.9	2560	75000	0.65	14000	1.1	3500	75000	
A 90 4_865.1	865.1	1.0	14000	1.7	2240	75000	0.58	14000	0.95	3500	75000	
A 90 4_937.2	937.2	0.96	14000	1.6	2660	75000	0.53	14000	0.88	3500	75000	
A 90 4_1025	1025	0.88	14000	1.4	2400	75000	0.49	14000	0.80	3500	75000	
A 90 4_1111	1111	0.81	14000	1.3	2810	75000	0.45	14000	0.74	3500	75000	
A 90 4_1222	1222	0.74	14000	1.2	2450	75000	0.41	14000	0.67	3500	75000	
A 90 4_1324	1324	0.68	14000	1.1	2860	75000	0.38	14000	0.62	3500	75000	
A 90 4_1507	1507	0.60	14000	0.98	2410	75000	0.33	14000	0.55	3500	75000	
A 90 4_1632	1632	0.55	14000	0.91	2910	75000	0.31	14000	0.50	3500	75000	

(—) Interpellare il ns. servizio tecnico comunicando i dati relativi al carico radiale (senso di rotazione, orientamento, posizione)
 (—) Contact our technical service department advising radial load data (rotation direction, orientation, position)
 (—) Nehmen Sie bitte Kontakt mit unserem Applikationsdienst und Querkräftsdaten angeben (Drehrichtung, Orientierung, Anordnung)
 (—) Consulter notre service technique en donnant les d'États concernant la charge radiale (sens de rotation, indexage, position)

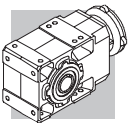

31 - PREDISPOSIZIONI MOTORE

Nelle tabelle (B12) e (B13) vengono riportati gli abbinamenti motore possibili in termini puramente geometrici.

La scelta del motoriduttore deve essere effettuata seguendo le istruzioni specificate al paragrafo 11, rispettando in particolare la condizione $S \geq f_s$.

31 - MOTOR AVAILABILITY

Please be aware that motor-gearbox combinations resulting from charts (B12) and (B13) are purely based on geometrical compatibility.

When selecting a gearmotor, refer to procedure specified at paragraph 11 and observe particularly the condition $S \geq f_s$.

31 - BAUMÖGLICHKEITEN

In den Tabellen (B12) und (B13) werden die von den Größen her gesehenden möglichen Passungen angegeben.

Die angemessene Getriebewahl muss unter Befolgung der im Paragraph 11 gegebenen Anleitungen und auf der Grundlage der Auswahltablelle der technischen Daten erfolgen.

31 - PREDISPOSITIONS MOTEUR

Dans les tableaux (B12) et (B13) sont indiqués les accouplements possibles en termes des dimensions.

Le choix le plus approprié du motoréducteur à utiliser doit être effectué selon les indications du paragraphe 11, ainsi qu'en fonction des tableaux de sélection, respectant en particulier la condition $S \geq f_s$.

(B12)

		IEC_  (IM B5)											
		P63	P71	P80	P90	P100	P112	P132	P160	P180	P200	P225	P250
A 05 2		5.5_91.6	5.5_51.3	5.5_51.3									
A 10 2		5.5_91.6	5.5_91.6	5.5_65.9	5.5_65.9	5.5_65.9	5.5_65.9						
A 20 2		7.3_92.3 ⊖(10.3)	7.3_92.3 ⊖(10.3)	5.4_79.9	5.4_79.9	5.4_79.9	5.4_79.9						
A 20 3		109.2_380.8	109.2_380.8	109.2_380.8	109.2_380.8	109.2_380.8	109.2_380.8						
A 30 2		9.3_97.5 ⊖(10.5; 13.6_16.3)	9.3_97.5 ⊖(10.5; 13.6_16.3)	5.4_97.5	5.4_97.5	5.4_97.5	5.4_97.5						
A 30 3		109.1_400.8	109.1_400.8	109.1_400.8	109.1_400.8	109.1_400.8	109.1_400.8						
A 35 2		9.3_95.6 ⊖(13.1_20.4)	9.3_95.6 ⊖(13.1_20.4)	5.4_95.6	5.4_95.6	5.4_95.6	5.4_95.6	5.4_11.8					
A 35 3		105.5_393.2	105.5_393.2	105.5_393.2	105.5_393.2	105.5_393.2	105.5_393.2						
A 41 2		11.7_79.2 ⊖(13.8_17.8)	11.7_79.2 ⊖(13.8_17.8)	5.2_79.2	5.2_79.2	5.2_79.2	5.2_79.2	5.2_45.1					
A 41 3		92.8_376.8	92.8_376.8	92.8_376.8	92.8_376.8	92.8_376.8	92.8_376.8						
A 50 2		20.9	20.9	7.7_20.9	7.7_20.9	7.7_20.9	7.7_20.9	7.7_20.9	7.7_20.9	7.7_20.9			
A 50 3		51.7_190.6	51.7_190.6	24.0_190.6	24.0_190.6	24.0_190.6	24.0_190.6	24.0_109.4	24.0_109.4	24.0_109.4			
A 50 4	i =	211.0_778.2	211.0_778.2	211.0_778.2	211.0_778.2	211.0_778.2	211.0_778.2						
A 55 2				13.1_19.2	13.1_19.2	13.1_19.2	13.1_19.2	4.9_19.2	4.9_19.2	4.9_19.2			
A 55 3		64.3_194.2	64.3_194.2	23.8_194.2	23.8_194.2	23.8_194.2	23.8_194.2	23.8_123.9	23.8_123.9	23.8_123.9			
A 55 4		208.1_793.0	208.1_793.0	208.1_793.0	208.1_793.0	208.1_793.0	208.1_793.0						
A 60 2				10.3_20.6	10.3_20.6	10.3_20.6	10.3_20.6	7.9_20.6	7.9_20.6	7.9_20.6			
A 60 3		65.0_185.8	65.0_185.8	25.7_185.8	25.7_185.8	25.7_185.8	25.7_185.8	25.7_133.3	25.7_133.3	25.7_133.3			
A 60 4		208.7_755.4	208.7_755.4	208.7_755.4	208.7_755.4	208.7_755.4	208.7_755.4						
A 70 3				66.9_153.7	66.9_153.7	66.9_153.7	66.9_153.7	15.4_153.7 ⊖(23.5_30.1)	9.4_153.7	9.4_153.7	9.4_38.4 ⊖(19.7_21.3)		
A 70 4		292.0_1715	292.0_1715	169.8_1715	169.8_1715	169.8_1715	169.8_1715	169.8_644.6					
A 80 3				82.3_156.8	82.3_156.8	82.3_156.8	82.3_156.8	19.3_156.8 ⊖(22.6_38.5)	12.3_156.8 ⊖(22.6_24.5)	9.8_156.8	9.8_104.0	9.8_104.0	
A 80 4		354.0_1558	354.0_1558	171.3_1558	171.3_1558	171.3_1558	171.3_1558	171.3_762.1					
A 90 3				98.6_151.0	98.6_151.0	98.6_151.0	98.6_151.0	55.0_151.0	19.4_151.0 ⊖(22.3_38.8)	9.7_151.0	9.7_126.6	9.7_126.6	9.7_126.6
A 90 4		449.2_1632	449.2_1632	166.1_1632	166.1_1632	166.1_1632	166.1_1632	166.1_937.2	166.1_937.2	166.1_937.2			

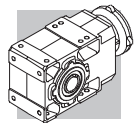

(B13)

							
		M05	M1	M2	M3	M4	M5
A 05 2	i =	5.5_91.6	5.5_51.3	5.5_65.9			
A 10 2		5.5_91.6	5.5_51.3	5.5_65.9	5.5_65.9		
A 20 2		7.3_92.3 ⊖(10.3)	7.3_63.1 ⊖(10.3)	5.4_79.9	5.4_79.9		
A 20 3		109.2_380.8	109.2_380.8	109.2_380.8	109.2_380.8		
A 30 2			9.3_76.5 ⊖(10.5 ; 13.6_16.3)	5.4_97.5	5.4_97.5		
A 30 3		109.1_400.8	109.1_400.8	109.1_400.8	109.1_400.8		
A 35 2			9.3_95.6 ⊖(13.1_20.4)	5.4_95.6	5.4_95.6	5.4_11.8	
A 35 3		105.5_393.2	105.5_393.2	105.5_393.2	105.5_393.2		
A 41 2			11.7_79.2 ⊖(13.8_17.8)	5.2_79.2	5.2_79.2	5.2_45.1	
A 41 3		92.8_376.8	92.8_376.8	92.8_376.8	92.8_376.8		
A 50 2			20.9	7.7_20.9	7.7_20.9	7.7_20.9	7.7_20.9
A 50 3			51.7_190.6	24.0_190.6	24.0_190.6	24.0_109.4	24.0_109.4
A 50 4			211.0_778.2	211.0_778.2	211.0_778.2		
A 55 2				13.1_19.2	13.1_19.2	4.9_19.2	4.9_19.2
A 55 3			64.3_194.2	23.8_194.2	23.8_194.2	23.8_123.9	23.8_123.9
A 55 4			208.1_793.0	208.1_793.0	208.1_793.0		
A 60 2				10.3_20.6	10.3_20.6	7.9_20.6	7.9_20.6
A 60 3				25.7_185.8	25.7_185.8	25.7_133.3	25.7_133.3
A 60 4			208.7_755.4	208.7_755.4	208.7_755.4		
A 70 3				66.9_153.7	66.9_153.7	15.4_153.7 ⊖(23.5_30.1)	15.4_153.7 ⊖(23.5_30.1)
A 70 4			292.0_1715	169.8_1715	169.8_1715	169.8_644.6	
A 80 3					82.3_156.8	19.3_156.8 ⊖(22.6_38.5)	19.3_156.8 ⊖(22.6_38.5)
A 80 4			354.0_1558	171.3_1558	171.3_1558	171.3_762.1	
A 90 3					98.6_151.0	55.0_151.0	55.0_151.0
A 90 4		449.2_1632	166.1_1632	166.1_1632	166.1_937.2		

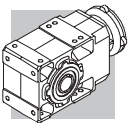

Predisposizioni motore sono disponibili per l'abbinamento dei riduttori A05...A60 con i servomotori delle tipologie più diffuse. Le dimensioni delle flange sono reperibili nella sezione dimensionale di ogni singolo riduttore. La sigla **SK** identifica calettamenti con l'albero motore dotati di sede per chiavetta, mentre la sigla **SC** corrisponde al calettamento mediante morsetto di serraggio (fornito).

Motor adapters matching the most popular brands of servomotors are available for units size A05...A60. Dimensions of servomotor inputs are provided within the drawing section for each frame size.

*The code **SK** applies for inputs featuring a conventional keyway, while through the specification of the **SC** code the input shaft will feature a clamping device instead.*

Für viele Servomotoren der wichtigsten Hersteller stehen passende Motoradapter für die Baugrößen A05...A60 zur Verfügung. Die Abmessungen der Servomotor-Eingänge entnehmen Sie bitte dem Zeichnungsteil der verschiedenen Baugrößen. Der Bezeichnungszusatz **SK** steht für Eingänge mit herkömmlicher Passfedernut. Der Zusatz **SC** bezieht sich stattdessen auf Eingänge mit Klemmvorrichtung.

Sont disponibles des prédispositions pour l'accouplement des réducteurs A05...A60 avec les servomoteurs les plus répandus. Les dimensions des brides sont indiquées dans les pages des dimensions de chaque réducteur.

*Le code **SK** indique un arbre d'entrée muni de rainure de clavette; le code **SC** indique un arbre d'entrée muni de frette de serrage (fournie).*

(B14a)

		SERVO INPUT							
		SK40A	SK60A	SK60B	SK80A	SK80B	SK80C		
		SC40A	SC60A	SC60B	SC80A	SC80B	SC80C		
A 05 2	i =	5.5_91.6	5.5_91.6	5.5_51.3	5.5_51.3				
A 10 2			5.5_91.6	5.5_51.3	5.5_51.3			5.5_65.9	
A 20 2			7.3_92.3 ⊖(10.3)	7.3_63.1 ⊖(10.3)	7.3_63.1 ⊖(10.3)				5.4_79.9
A 20 3			109.2_380.8	109.2_380.8	109.2_380.8				109.2_380.8
A 30 2			9.3_97.5 ⊖(10.5; 13.6_16.3)	9.3_76.5 ⊖(10.5; 13.6_16.3)	9.3_76.5 ⊖(10.5; 13.6_16.3)				5.4_97.5
A 30 3			109.1_400.8	109.1_400.8	109.1_400.8				109.1_400.8
A 35 2			9.3_95.6 ⊖(13.1_20.4)	9.3_95.6 ⊖(13.1_20.4)	9.3_95.6 ⊖(13.1_20.4)				5.4_95.6
A 35 3			105.5_393.2	105.5_393.2	105.5_393.2				105.5_393.2
A 41 2							11.7_79.2 ⊖(13.8_17.8)		5.2_79.2
A 41 3				92.8_376.8	92.8_376.8	92.8_376.8			92.8_376.8
A 50 2							20.9		7.7_20.9
A 50 3							51.7_190.6		24.0_190.6
A 50 4				211.0_778.2	211.0_778.2	211.0_778.2			211.0_778.2
A 55 2									13.1_19.2
A 55 3							64.3_194.2		23.8_194.2
A 55 4				208.1_793.0	208.1_793.0	208.1_793.0			208.1_793.0
A 60 2									10.3_20.6
A 60 3									25.7_185.8
A 60 4							208.7_755.4		208.7_755.4

(B14b)

		SERVO INPUT									
		SK95A	SK95B	SK95C	SK110A	SK110B	SK130A	SK130B	SK180A	SK180B	
		SC95A	SC95B	SC95C	SC110A	SC110B	SC130A	SC130B	SC180A	SC180B	
A 10 2	i =	5.5_51.3	5.5_65.9	5.5_65.9	5.5_65.9	5.5_65.9					
A 20 2		7.3_63.1 ⊖(10.3)	5.4_79.9	5.4_79.9	5.4_79.9	5.4_79.9					
A 20 3		109.2_380.8	109.2_380.8	109.2_380.8	109.2_380.8	109.2_380.8					
A 30 2		9.3_76.5 ⊖(10.5; 13.6_16.3)	5.4_97.5	5.4_97.5	5.4_97.5	5.4_97.5	5.4_97.5				
A 30 3		109.1_400.8	109.1_400.8	109.1_400.8	109.1_400.8	109.1_400.8					
A 35 2		9.3_95.6 ⊖(13.1_20.4)	5.4_95.6	5.4_95.6	5.4_95.6	5.4_95.6	5.4_95.6				
A 35 3		105.5_393.2	105.5_393.2	105.5_393.2	105.5_393.2	105.5_393.2					
A 41 2		11.7_79.2 ⊖(13.8_17.8)	5.2_79.2	5.2_79.2	5.2_79.2	5.2_79.2	5.2_79.2	5.2_45.1	5.2_45.1	5.2_45.1	
A 41 3		92.8_376.8	92.8_376.8	92.8_376.8	92.8_376.8	92.8_376.8					
A 50 2		20.9	7.7_20.9	7.7_20.9	7.7_20.9	7.7_20.9	7.7_20.9	7.7_20.9	7.7_20.9	7.7_20.9	
A 50 3		51.7_190.6	24.0_190.6	24.0_190.6	24.0_190.6	24.0_190.6	24.0_190.6	24.0_109.4	24.0_109.4	24.0_109.4	
A 50 4		211.0_778.2	211.0_778.2	211.0_778.2	211.0_778.2	211.0_778.2	211.0_778.2				
A 55 2			13.1_19.2	13.1_19.2	13.1_19.2	13.1_19.2	13.1_19.2	4.9_19.2	4.9_19.2	4.9_19.2	
A 55 3			64.3_194.2	23.8_194.2	23.8_194.2	23.8_194.2	23.8_194.2	23.8_123.9	23.8_123.9	23.8_123.9	
A 55 4			208.1_793.0	208.1_793.0	208.1_793.0	208.1_793.0	208.1_793.0				
A 60 2			10.3_20.6	10.3_20.6	10.3_20.6	10.3_20.6	10.3_20.6	7.9_20.6	7.9_20.6	7.9_20.6	
A 60 3			65.0_185.8	25.7_185.8	25.7_185.8	25.7_185.8	25.7_185.8	25.7_133.3	25.7_133.3	25.7_133.3	
A 60 4			208.7_755.4	208.7_755.4	208.7_755.4	208.7_755.4	208.7_755.4				

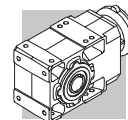

32 - MOMENTO D'INERZIA

32 - MOMENT OF INERTIA

32 - TRÄGHEITSMOMENT

32 - MOMENT D'INERTIE

Le tabelle seguenti indicano i valori del momento d'inerzia Jr [kgm²] riferiti all'asse veloce del riduttore; per una migliore facilità di lettura riportiamo le definizioni dei simboli usati.

The following charts indicate moment of inertia values Jr [kgm²] referred to the gear unit high speed shaft. A key to the symbols used follows:

Die In den folgenden Tabellen angegebenen Trägheitsmomente Jr [kgm²] beziehen sich auf die Getriebeantriebsachse. Um das Lesen der Tabellen zu erleichtern, werden folgende Symbole verwendet:

Les tableaux suivants indiquent les valeurs du moment d'inertie Jr [kgm²] du niveau de l'arbre rapide du réducteur; pour une plus grande facilité de lecture, nous vous prions de noter les définitions des symboles employés.



I valori riferiti a questo simbolo sono da attribuire al riduttore compatto senza motore. In questo caso, per avere il momento d'inerzia complessivo del motoriduttore, si dovrà sommare il valore corrispondente al riduttore compatto, a quello del motore da applicare (dato reperibile nelle tabelle delle caratteristiche tecniche dei motori elettrici).

Values under this icon refer to compact gear units, without motor. To obtain the overall moment of inertia for the gearmotor just add the value of the inertia for the specific compact motor, given in the relevant rating chart.

Kompaktgetriebe ohne Motor. In diesem Fall muß man, um das Gesamtträgheitsmoment des Getriebemotors zu erhalten, den dem Kompaktgetriebe mit der gewählten Übersetzung entsprechenden Wert mit dem Wert des anzuschließenden Motors addieren (dieser Wert kann den Elektromotorenauswahltabellen entnommen werden).

Les valeurs liées à symbole sont à assigner au réducteur compact sans moteur. Dans ce cas, afin d'avoir le moment d'inertie total du motoréducteur, on devra additionner la valeur correspondant au réducteur compact, à celle du moteur à assembler (donnée que l'on peut repérer dans les tableaux des caractéristiques techniques des moteurs électriques).



I valori relativi a questi simboli sono da attribuire al riduttore predisposto per attacco motore (grandezza IEC...).

Values under this symbol refer to gearboxes with IEC motor adaptor (IEC size...).

Nur Getriebe vorbereitet für IEC-Motor (IEC-Größe...).

Les valeurs liées à ces symboles sont à assigner au réducteur préparé pour accouplement moteur seulement (taille IEC...).





I valori attribuiti al riduttore sono riferiti a questo simbolo.

This symbol refers to gearbox values.

Dieses Symbol bezieht sich auf Getriebewerte.



Les valeurs liées au réducteur sont assignées à ce symbole.

A 05

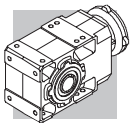
		J (•10 ⁻⁴) [kgm ²]				
i		 IEC				
		63	71	80		
A 05 2_5.5	5.5	0.72	0.99	1.0	1.4	—
A 05 2_6.3	6.3	0.56	0.83	0.86	1.2	—
A 05 2_7.2	7.2	0.48	0.74	0.77	1.1	—
A 05 2_8.5	8.5	0.36	0.63	0.65	1.0	—
A 05 2_9.6	9.6	0.29	0.55	0.58	0.92	—
A 05 2_10.6	10.6	0.50	0.77	0.80	1.1	—
A 05 2_12.3	12.3	0.18	0.45	0.48	0.82	—
A 05 2_13.9	13.9	0.35	0.62	0.65	0.99	—
A 05 2_16.4	16.4	0.27	0.54	0.57	0.91	—
A 05 2_18.6	18.6	0.22	0.49	0.51	0.86	—
A 05 2_21.4	21.4	0.16	0.43	0.46	0.80	—
A 05 2_23.8	23.8	0.14	0.41	0.43	0.78	—
A 05 2_25.5	25.5	0.13	0.39	0.42	0.76	—
A 05 2_28.6	28.6	0.11	0.38	0.40	0.75	—
A 05 2_32.2	32.2	0.09	0.36	0.39	0.73	—
A 05 2_35.1	35.1	0.08	0.35	0.37	0.72	—
A 05 2_40.9	40.9	0.07	0.33	0.36	0.70	—
A 05 2_45.4	45.4	0.05	0.32	0.35	0.69	—
A 05 2_51.3	51.3	0.04	0.31	0.34	0.68	—
A 05 2_58.6	58.6	0.04	0.31	—	—	—
A 05 2_65.9	65.9	0.03	0.30	—	—	—
A 05 2_76.4	76.4	0.02	0.29	—	—	—
A 05 2_91.6	91.6	0.02	0.28	—	—	—



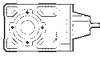

A 10

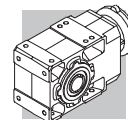
	i	J ($\cdot 10^{-4}$) [kgm ²]							
			 IEC						
			63	71	80	90	100	112	
A 10 2_5.5	5.5	1.0	2.5	2.5	3.9	3.8	5.1	5.1	1.8
A 10 2_6.3	6.3	0.80	2.3	2.3	3.7	3.6	4.9	4.9	1.6
A 10 2_7.2	7.2	0.60	2.1	2.1	3.5	3.4	4.7	4.7	1.5
A 10 2_8.5	8.5	0.45	1.9	1.9	3.3	3.1	4.5	4.5	1.4
A 10 2_9.6	9.6	0.30	1.8	1.8	3.2	3.1	4.4	4.4	1.3
A 10 2_10.6	10.6	0.50	2.0	2.0	3.4	3.3	4.6	4.6	1.4
A 10 2_12.3	12.3	0.20	1.7	1.7	3.1	3.0	4.3	4.3	1.1
A 10 2_13.9	13.9	0.30	1.8	1.8	3.2	3.1	4.6	4.6	1.2
A 10 2_16.4	16.4	0.25	1.7	1.7	3.1	3.0	4.3	4.3	1.1
A 10 2_18.6	18.6	0.20	1.7	1.7	3.1	3.0	4.3	4.3	1.0
A 10 2_21.4	21.4	0.15	1.6	1.6	3.0	2.9	4.2	4.2	1.0
A 10 2_23.8	23.8	0.10	1.6	1.6	3.0	2.9	4.2	4.2	1.0
A 10 2_25.5	25.5	0.10	1.6	1.6	3.0	2.9	4.2	4.2	1.0
A 10 2_28.6	28.6	0.10	1.6	1.6	3.0	2.9	4.2	4.2	0.90
A 10 2_32.2	32.2	0.08	1.6	1.6	3.0	2.9	4.2	4.2	0.90
A 10 2_35.1	35.1	0.07	1.6	1.6	3.0	2.9	4.2	4.2	0.90
A 10 2_40.9	40.9	0.06	1.6	1.6	3.0	2.9	4.2	4.2	0.90
A 10 2_45.4	45.4	0.05	1.6	1.6	3.0	2.9	4.2	4.2	0.90
A 10 2_51.3	51.3	0.03	1.5	1.5	2.9	2.8	4.1	4.1	0.90
A 10 2_58.6	58.6	0.03	1.5	1.5	2.9	2.8	4.1	4.1	0.90
A 10 2_65.9	65.9	0.02	1.5	1.5	2.9	2.8	4.1	4.1	0.90
A 10 2_76.4	76.4	0.02	1.5	1.5	—	—	—	—	0.90
A 10 2_91.6	91.6	0.01	1.5	1.5	—	—	—	—	0.90



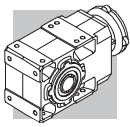

A 20

	i	J ($\cdot 10^{-4}$) [kgm ²]							
			IEC 						
			63	71	80	90	100		112
A 20 2_5.4	5.4	2.4	—	—	5.3	5.2	6.5	6.5	4.3
A 20 2_6.5	6.5	1.9	—	—	4.8	4.7	6.0	6.0	3.8
A 20 2_7.3	7.3	1.4	2.9	2.9	4.3	4.2	5.5	5.5	3.3
A 20 2_8.4	8.4	1.1	2.6	2.6	4.0	3.9	5.2	5.2	3.0
A 20 2_9.4	9.4	0.90	2.4	2.4	3.8	3.7	5.0	5.0	2.8
A 20 2_10.3	10.3	1.2	—	—	4.1	4.0	5.3	5.3	3.0
A 20 2_12.0	12.0	0.50	2.0	2.0	3.4	3.3	4.6	4.6	2.4
A 20 2_14.1	14.1	0.70	2.2	2.2	3.6	3.5	4.8	4.8	2.6
A 20 2_16.2	16.2	0.55	2.0	2.0	3.4	3.3	4.6	4.6	2.5
A 20 2_18.1	18.1	0.40	1.9	1.9	3.3	3.2	4.5	4.5	2.4
A 20 2_21.2	21.2	0.35	1.8	1.8	3.2	3.1	4.4	4.4	2.3
A 20 2_23.1	23.1	0.30	1.8	1.8	3.2	3.1	4.4	4.4	2.2
A 20 2_26.5	26.5	0.25	1.7	1.7	3.1	3.0	4.3	4.3	2.1
A 20 2_29.2	29.2	0.20	1.7	1.7	3.1	3.0	4.3	4.3	2.1
A 20 2_31.3	31.3	0.20	1.7	1.7	3.1	3.0	4.3	4.3	2.1
A 20 2_35.4	35.4	0.20	1.7	1.7	3.1	3.0	4.3	4.3	2.1
A 20 2_39.6	39.6	0.10	1.6	1.6	3.0	2.9	4.2	4.2	2.0
A 20 2_43.2	43.2	0.10	1.6	1.6	3.0	2.9	4.2	4.2	2.0
A 20 2_48.3	48.3	0.10	1.6	1.6	3.0	2.9	4.2	4.2	2.0
A 20 2_53.7	53.7	0.10	1.6	1.6	3.0	2.9	4.2	4.2	2.0
A 20 2_63.1	63.1	0.10	1.6	1.6	3.0	2.9	4.2	4.2	2.0
A 20 2_71.0	71.0	0.05	1.5	1.5	2.9	2.8	4.1	4.1	2.0
A 20 2_79.9	79.9	0.03	1.5	1.5	2.9	2.8	4.1	4.1	2.0
A 20 2_92.3	92.3	0.02	1.5	1.5	—	—	—	—	2.0
A 20 3_109.2	109.2	0.02	1.5	1.5	2.9	2.8	4.1	4.1	0.90
A 20 3_120.5	120.5	0.02	1.5	1.5	2.9	2.8	4.1	4.1	0.90
A 20 3_129.1	129.1	0.02	1.5	1.5	2.9	2.8	4.1	4.1	0.90
A 20 3_146.1	146.1	0.02	1.5	1.5	2.9	2.8	4.1	4.1	0.90
A 20 3_163.4	163.4	0.01	1.5	1.5	2.9	2.8	4.1	4.1	0.90
A 20 3_178.3	178.3	0.01	1.5	1.5	2.9	2.8	4.1	4.1	0.90
A 20 3_199.2	199.2	0.01	1.5	1.5	2.9	2.8	4.1	4.1	0.90
A 20 3_221.3	221.3	0.01	1.5	1.5	2.9	2.8	4.1	4.1	0.90
A 20 3_260.5	260.5	0.01	1.5	1.5	2.9	2.8	4.1	4.1	0.90
A 20 3_292.8	292.8	0.01	1.5	1.5	2.9	2.8	4.1	4.1	0.90
A 20 3_329.4	329.4	0.01	1.5	1.5	2.9	2.8	4.1	4.1	0.90
A 20 3_380.8	380.8	0.01	1.5	1.5	2.9	2.8	4.1	4.1	0.90



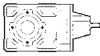

A 30

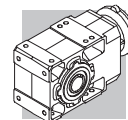
	i	J ($\cdot 10^{-4}$) [kgm ²]							
			IEC 						
			63	71	80	90	100	112	
A 30 2_5.4	5.4	4.5	—	—	7.4	7.3	8.6	8.6	6.9
A 30 2_6.4	6.4	3.4	—	—	6.6	6.6	7.8	7.8	6.0
A 30 2_7.0	7.0	2.9	—	—	5.8	5.8	7.0	7.0	5.2
A 30 2_8.5	8.5	2.2	—	—	5.1	5.1	6.3	6.3	4.6
A 30 2_9.3	9.3	1.6	3.1	3.1	4.5	4.4	5.7	5.7	4.0
A 30 2_10.5	10.5	2.3	—	—	5.2	5.1	6.4	6.4	4.6
A 30 2_11.8	11.8	1.1	2.6	2.6	4.0	3.9	5.2	5.2	3.4
A 30 2_13.6	13.6	1.5	—	—	4.4	4.3	5.6	5.6	3.9
A 30 2_16.3	16.3	1.2	—	—	4.1	4.0	5.3	5.3	3.5
A 30 2_18.0	18.0	0.90	2.4	2.4	3.8	3.7	5.0	5.0	3.2
A 30 2_20.5	20.5	0.70	2.2	2.2	3.6	3.5	4.8	4.8	3.1
A 30 2_22.8	22.8	0.60	2.1	2.1	3.5	3.4	4.7	4.7	3.0
A 30 2_26.5	26.5	0.50	2.0	2.0	3.4	3.3	4.6	4.6	2.9
A 30 2_29.3	29.3	0.40	1.9	1.9	3.3	3.2	4.5	4.5	2.8
A 30 2_33.4	33.4	0.35	1.8	1.8	3.2	3.1	4.4	4.4	2.7
A 30 2_36.6	36.6	0.30	1.8	1.8	3.2	3.1	4.4	4.4	2.7
A 30 2_39.3	39.3	0.25	1.7	1.7	3.1	3.0	4.3	4.3	2.6
A 30 2_43.4	43.4	0.20	1.7	1.7	3.1	3.0	4.3	4.3	2.6
A 30 2_48.3	48.3	0.20	1.7	1.7	3.1	3.0	4.3	4.3	2.6
A 30 2_52.7	52.7	0.20	1.7	1.7	3.1	3.0	4.3	4.3	2.5
A 30 2_59.4	59.4	0.10	1.6	1.6	3.0	2.9	4.2	4.2	2.5
A 30 2_66.0	66.0	0.10	1.6	1.6	3.0	2.9	4.2	4.2	2.5
A 30 2_76.5	76.5	0.10	1.6	1.6	3.0	2.9	4.2	4.2	2.5
A 30 2_86.7	86.7	0.10	1.6	1.6	3.0	2.9	4.2	4.2	2.5
A 30 2_97.5	97.5	0.10	1.6	1.6	3.0	2.9	4.2	4.2	2.4
A 30 3_109.1	109.1	0.10	1.6	1.6	3.0	2.9	4.2	4.2	0.90
A 30 3_120.5	120.5	0.10	1.6	1.6	3.0	2.9	4.2	4.2	0.90
A 30 3_137.4	137.4	0.10	1.6	1.6	3.0	2.9	4.2	4.2	0.90
A 30 3_150.7	150.7	0.10	1.6	1.6	3.0	2.9	4.2	4.2	0.90
A 30 3_161.4	161.4	0.10	1.6	1.6	3.0	2.9	4.2	4.2	0.90
A 30 3_178.6	178.6	0.10	1.6	1.6	3.0	2.9	4.2	4.2	0.90
A 30 3_198.5	198.5	0.10	1.6	1.6	3.0	2.9	4.2	4.2	0.90
A 30 3_216.6	216.6	0.10	1.6	1.6	3.0	2.9	4.2	4.2	0.90
A 30 3_244.3	244.3	0.10	1.6	1.6	3.0	2.9	4.2	4.2	0.90
A 30 3_271.5	271.5	0.10	1.6	1.6	3.0	2.9	4.2	4.2	0.90
A 30 3_314.6	314.6	0.10	1.6	1.6	3.0	2.9	4.2	4.2	0.90
A 30 3_356.3	356.3	0.06	1.6	1.6	3.0	2.9	4.2	4.2	0.90
A 30 3_400.8	400.8	0.04	1.5	1.6	2.9	2.8	4.1	4.1	0.90



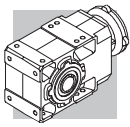

A 35

	i	J ($\cdot 10^{-4}$) [kgm ²]								
			IEC 							
			63	71	80	90	100	112	132	
A 35 2_5.4	5.4	7.3	—	—	10	9.9	11	11	24	9.4
A 35 2_6.4	6.4	5.4	—	—	8.1	8.0	9.2	9.2	22	7.4
A 35 2_7.0	7.0	4.6	—	—	7.3	7.2	8.4	8.4	21	6.6
A 35 2_8.5	8.5	3.3	—	—	6.1	5.9	7.1	7.1	20	5.4
A 35 2_9.3	9.3	2.8	3.5	3.5	5.6	5.4	6.6	6.6	19	4.9
A 35 2_10.6	10.6	2.1	2.9	2.9	4.9	4.8	6.0	6.0	19	4.2
A 35 2_11.8	11.8	1.8	2.5	2.5	4.6	4.4	5.7	5.7	18	3.9
A 35 2_13.1	13.1	3.0	—	—	5.7	5.6	6.8	6.8	—	5.0
A 35 2_15.5	15.5	2.2	—	—	5.0	4.9	6.1	6.1	—	4.3
A 35 2_17.0	17.0	2.0	—	—	4.7	4.6	5.8	5.8	—	4.0
A 35 2_20.4	20.4	1.6	—	—	4.3	4.2	5.4	5.4	—	3.6
A 35 2_22.5	22.5	1.3	2.0	2.0	4.1	3.9	5.1	5.1	—	3.4
A 35 2_25.7	25.7	0.97	1.7	1.7	3.7	3.6	4.8	4.8	—	3.0
A 35 2_28.4	28.4	0.86	1.6	1.6	3.6	3.5	4.7	4.7	—	2.9
A 35 2_33.2	33.2	0.69	1.4	1.4	3.5	3.3	4.5	4.5	—	2.8
A 35 2_36.6	36.6	0.58	1.3	1.3	3.3	3.2	4.4	4.4	—	2.6
A 35 2_41.8	41.8	0.48	1.2	1.2	3.2	3.1	4.3	4.3	—	2.5
A 35 2_45.8	45.8	0.42	1.1	1.1	3.2	3.1	4.3	4.3	—	2.5
A 35 2_49.1	49.1	0.38	1.1	1.1	3.1	3.0	4.2	4.2	—	2.4
A 35 2_54.3	54.3	0.33	1.1	1.0	3.1	3.0	4.2	4.2	—	2.4
A 35 2_60.4	60.4	0.29	1.0	1.0	3.0	2.9	4.1	4.1	—	2.3
A 35 2_65.8	65.8	0.25	1.0	1.0	3.0	2.9	4.1	4.1	—	2.3
A 35 2_74.3	74.3	0.21	0.95	0.93	3.0	2.8	4.1	4.1	—	2.3
A 35 2_82.5	82.5	0.18	0.92	0.90	2.9	2.8	4.0	4.0	—	2.2
A 35 2_95.6	95.6	0.15	0.88	0.87	2.9	2.8	4.0	4.0	—	2.2
A 35 3_105.5	105.5	0.11	0.89	0.87	2.9	2.8	4.0	4.0	—	0.80
A 35 3_116.9	116.9	0.11	0.88	0.87	2.9	2.8	4.0	4.0	—	0.79
A 35 3_136.3	136.3	0.10	0.87	0.86	2.9	2.8	4.0	4.0	—	0.78
A 35 3_150.6	150.6	0.09	0.86	0.85	2.9	2.8	4.0	4.0	—	0.77
A 35 3_171.8	171.8	0.08	0.86	0.84	2.9	2.8	4.0	4.0	—	0.77
A 35 3_188.3	188.3	0.08	0.85	0.84	2.9	2.7	4.0	4.0	—	0.76
A 35 3_201.8	201.8	0.08	0.85	0.84	2.9	2.7	4.0	4.0	—	0.76
A 35 3_223.2	223.2	0.08	0.85	0.84	2.9	2.7	4.0	4.0	—	0.76
A 35 3_248.1	248.1	0.07	0.85	0.83	2.9	2.7	4.0	4.0	—	0.76
A 35 3_270.7	270.7	0.07	0.84	0.83	2.9	2.7	4.0	4.0	—	0.75
A 35 3_305.4	305.4	0.07	0.84	0.83	2.9	2.7	4.0	4.0	—	0.75
A 35 3_339.3	339.3	0.07	0.84	0.83	2.9	2.7	4.0	4.0	—	0.75
A 35 3_393.2	393.2	0.07	0.84	0.83	2.9	2.7	3.9	3.9	—	0.75



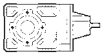

A 41

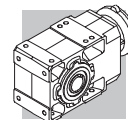
	i	J ($\cdot 10^{-4}$) [kgm ²]								
			IEC 							
			63	71	80	90	100	112	132	
A 41 2_5.2	5.2	13	—	—	16	16	17	17	32	23
A 41 2_7.1	7.1	7.3	—	—	10	10	11	11	26	18
A 41 2_8.3	8.3	5.9	—	—	8.8	8.7	10	10	25	16
A 41 2_9.2	9.2	4.5	—	—	7.4	7.3	8.6	8.6	23	15
A 41 2_10.1	10.1	5.9	—	—	8.8	8.7	10	10	25	16
A 41 2_11.7	11.7	2.9	4.4	4.4	5.8	5.7	7.0	7.0	22	13
A 41 2_13.8	13.8	3.6	—	—	6.5	6.4	7.7	7.7	23	14
A 41 2_16.1	16.1	2.9	—	—	5.8	5.7	7.0	7.0	22	13
A 41 2_17.8	17.8	2.2	—	—	5.1	5.0	6.3	6.3	21	11
A 41 2_22.7	22.7	1.5	3.0	3.0	4.4	4.3	5.6	5.6	20	11
A 41 2_28.3	28.3	1.1	2.6	2.6	4.0	3.9	5.2	5.2	20	10
A 41 2_35.9	35.9	1.7	3.2	3.2	4.6	4.5	5.8	5.8	20	9.8
A 41 2_45.1	45.1	1.5	3.0	3.0	4.4	4.3	5.6	5.6	20	9.6
A 41 2_48.3	48.3	1.4	2.9	2.9	4.3	4.2	5.5	5.5	—	9.5
A 41 2_53.1	53.1	1.4	2.9	2.9	4.3	4.2	5.5	5.5	—	9.5
A 41 2_58.8	58.8	1.3	2.8	2.8	4.2	4.1	5.4	5.4	—	9.4
A 41 2_64.2	64.2	1.3	2.8	2.8	4.2	4.1	5.4	5.4	—	9.4
A 41 2_71.3	71.3	1.2	2.7	2.7	4.1	4.0	5.3	5.3	—	9.3
A 41 2_79.2	79.2	1.2	2.7	2.7	4.1	4.0	5.3	5.3	—	9.3
A 41 3_92.8	92.8	1.1	2.6	2.6	4.0	3.9	5.2	5.2	—	9.2
A 41 3_115.9	115.9	0.20	1.7	1.7	2.9	3.0	4.3	4.3	—	2.1
A 41 3_146.9	146.9	0.10	1.6	1.6	2.8	2.9	4.2	4.2	—	2.1
A 41 3_184.4	184.4	0.10	1.6	1.6	2.8	2.9	4.2	4.2	—	2.1
A 41 3_197.5	197.5	0.10	1.6	1.6	2.8	2.9	4.2	4.2	—	2.0
A 41 3_217.4	217.4	0.10	1.6	1.6	2.8	2.9	4.2	4.2	—	2.0
A 41 3_240.6	240.6	0.10	1.6	1.6	2.8	2.9	4.2	4.2	—	2.0
A 41 3_262.5	262.5	0.10	1.6	1.6	2.8	2.9	4.2	4.2	—	2.0
A 41 3_291.7	291.7	0.10	1.6	1.6	2.8	2.9	4.2	4.2	—	2.0
A 41 3_324.2	324.2	0.10	1.6	1.6	2.8	2.9	4.2	4.2	—	2.0
A 41 3_376.8	376.8	0.10	1.6	1.6	2.8	2.9	4.2	4.2	—	2.0





A 50

	i	J ($\cdot 10^{-4}$) [kgm ²]										
			 IEC									
			63	71	80	90	100	112	132	160	180	
A 50 2_7.7	7.7	15	—	—	18	18	19	19	34	93	91	24
A 50 2_9.7	9.7	10	—	—	13	13	14	14	29	89	86	19
A 50 2_13.1	13.1	6.3	—	—	9.2	9.1	10	10	25	85	82	15
A 50 2_16.6	16.6	4.2	—	—	7.0	7.0	8.2	8.2	23	82	80	13
A 50 2_20.9	20.9	2.8	4.2	4.2	5.7	5.6	6.9	6.9	22	81	79	12
A 50 3_24.0	24.0	6.0	—	—	8.9	8.8	10	10	25	84	82	15
A 50 3_26.4	26.4	5.8	—	—	8.7	8.6	9.9	9.9	25	84	82	15
A 50 3_32.4	32.4	4.0	—	—	6.8	6.8	8.1	8.1	23	82	80	13
A 50 3_35.6	35.6	3.9	—	—	6.7	6.7	8.0	8.0	23	82	80	13
A 50 3_40.9	40.9	2.7	—	—	5.6	5.5	6.8	6.8	22	81	79	12
A 50 3_45.0	45.0	2.6	—	—	5.5	5.4	6.7	6.7	22	81	79	12
A 50 3_51.7	51.7	1.9	3.4	3.4	4.7	4.7	6.0	6.0	21	80	78	11
A 50 3_56.8	56.8	1.9	3.3	3.3	4.7	4.6	5.9	5.9	21	80	78	11
A 50 3_63.9	63.9	1.4	2.9	2.8	4.2	4.2	5.5	5.5	20	80	77	11
A 50 3_70.2	70.2	1.4	2.8	2.8	4.2	4.1	5.4	5.4	20	80	77	10
A 50 3_81.5	81.5	0.90	2.4	2.4	3.8	3.7	5.0	5.0	20	79	77	10
A 50 3_89.5	89.5	0.90	2.4	2.4	3.7	3.7	5.0	5.0	20	79	77	10
A 50 3_99.5	99.5	0.60	2.1	2.1	3.5	3.4	4.7	4.7	20	79	77	9.7
A 50 3_109.4	109.4	0.60	2.1	2.1	3.5	3.4	4.7	4.7	20	79	77	9.7
A 50 3_118.0	118.0	0.50	2.0	2.0	3.4	3.3	4.6	4.6	—	—	—	9.6
A 50 3_129.7	129.7	0.50	2.0	2.0	3.4	3.3	4.6	4.6	—	—	—	9.6
A 50 3_140.6	140.6	0.40	1.8	1.8	3.2	3.2	4.4	4.4	—	—	—	9.4
A 50 3_154.6	154.6	0.40	1.8	1.8	3.2	3.2	4.4	4.4	—	—	—	9.4
A 50 3_173.4	173.4	0.30	1.7	1.7	3.1	3.0	4.3	4.3	—	—	—	9.3
A 50 3_190.6	190.6	0.20	1.7	1.7	3.1	3.0	4.3	4.3	—	—	—	9.3

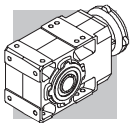
Per i valori dei momenti d'inerzia relativi ai riduttori a 4 stadi, consultare il ns. Servizio Tecnico.
 For the values of the moment of inertia of 4-stage gearboxes, please contact our Technical Service department.
 Im Hinblick auf die Trägheitsmomente der 4-stufigen Getriebe verweisen wir auf unseren Technischen Dienst.
 Quant aux valeurs des moments d'inertie, se référant aux réducteurs à 4 étages, consultez notre Service technique.



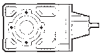

A 55

	i	J ($\cdot 10^{-4}$) [kgm ²]											
			 IEC										
			63	71	80	90	100	112	132	160	180		
A 55 2_4.9	4.9	61	—	—	—	—	—	—	—	77	123	120	70
A 55 2_6.4	6.4	41	—	—	—	—	—	—	—	57	103	100	50
A 55 2_8.5	8.5	26	—	—	—	—	—	—	—	42	88	85	35
A 55 2_10.4	10.4	19	—	—	—	—	—	—	—	35	81	78	28
A 55 2_13.1	13.1	12	—	—	14	14	17	17	28	74	72	21	
A 55 2_15.7	15.7	8.9	—	—	11	11	14	14	25	71	68	18	
A 55 2_19.2	19.2	6.2	—	—	8.6	8.5	11	11	23	68	66	15	
A 55 3_23.8	23.8	11	—	—	13	13	16	16	27	73	70	20	
A 55 3_29.9	29.9	7.9	—	—	10	10	13	13	24	70	67	17	
A 55 3_40.3	40.3	5.3	—	—	7.8	7.6	10	10	22	68	65	14	
A 55 3_51.0	51.0	3.6	—	—	6.0	5.9	8.6	8.6	20	66	63	13	
A 55 3_64.3	64.3	2.6	3.1	3.0	5.1	5.0	7.7	7.7	19	65	62	12	
A 55 3_79.5	79.5	2.0	2.4	2.4	4.5	4.4	7.1	7.1	18	64	62	11	
A 55 3_101.4	101.4	1.3	1.8	1.8	3.8	3.7	6.5	6.5	18	64	61	10	
A 55 3_123.9	123.9	1.0	1.5	1.5	3.6	3.4	6.2	6.2	17	63	61	10	
A 55 3_132.7	132.7	0.71	1.4	1.4	3.5	3.3	6.1	6.1	—	—	—	9.5	
A 55 3_146.8	146.8	0.66	1.4	1.4	3.4	3.3	6.0	6.0	—	—	—	9.4	
A 55 3_160.4	160.4	0.58	1.3	1.3	3.3	3.2	6.0	6.0	—	—	—	9.4	
A 55 3_175.0	175.0	0.50	1.2	1.2	3.3	3.1	5.9	5.9	—	—	—	9.3	
A 55 3_194.2	194.2	0.43	1.2	1.2	3.2	3.1	5.8	5.8	—	—	—	9.2	

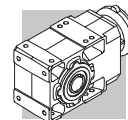
Per i valori dei momenti d'inerzia relativi ai riduttori a 4 stadi, consultare il ns. Servizio Tecnico.
 For the values of the moment of inertia of 4-stage gearboxes, please contact our Technical Service department.
 Im Hinblick auf die Trägheitsmomente der 4-stufigen Getriebe verweisen wir auf unseren Technischen Dienst.
 Quant aux valeurs des moments d'inertie, se référant aux réducteurs à 4 étages, consultez notre Service technique.





A 60

	i	J (*10 ⁻⁴) [kgm ²]											
			IEC 										
			63	71	80	90	100	112	132	160	180		
A 60 2_7.9	7.9	36	—	—	—	—	—	—	—	54	114	112	57
A 60 2_10.3	10.3	23	—	—	25	25	27	27	41	101	99	44	
A 60 2_12.7	12.7	16	—	—	19	19	20	20	35	94	92	37	
A 60 2_16.7	16.7	9.4	—	—	12	12	14	14	28	88	85	30	
A 60 2_20.6	20.6	6.7	—	—	9.6	9.5	11	11	26	85	83	28	
A 60 3_25.7	25.7	14	—	—	17	17	18	18	33	92	90	35	
A 60 3_27.9	27.9	14	—	—	17	17	18	18	33	92	90	35	
A 60 3_31.7	31.7	10	—	—	13	13	15	15	29	89	86	31	
A 60 3_34.3	34.3	10	—	—	13	13	14	14	29	89	86	31	
A 60 3_41.7	41.7	6.1	—	—	9.0	8.9	10	10	25	84	82	27	
A 60 3_45.2	45.2	6.1	—	—	8.9	8.9	10	10	25	84	82	27	
A 60 3_51.3	51.3	5.0	—	—	7.4	7.4	8.7	8.7	24	83	81	26	
A 60 3_55.6	55.6	4.5	—	—	7.4	7.3	8.6	8.6	23	83	81	26	
A 60 3_65.0	65.0	3.2	4.7	4.6	6.1	6.0	7.3	7.3	22	82	79	24	
A 60 3_70.4	70.4	3.2	4.7	4.6	6.1	6.0	7.3	7.3	22	81	79	24	
A 60 3_79.7	79.7	2.1	3.6	3.5	5.0	4.9	6.2	6.2	21	80	78	23	
A 60 3_86.4	86.4	2.1	3.6	3.5	5.0	4.9	6.2	6.2	21	80	78	23	
A 60 3_99.5	99.5	2.0	3.5	3.4	4.3	4.3	5.6	5.6	20	80	78	23	
A 60 3_107.8	107.8	1.5	3.0	2.9	4.3	4.3	5.6	5.6	20	80	78	22	
A 60 3_123.0	123.0	1.1	2.6	2.5	4.0	3.9	5.2	5.2	20	79	77	22	
A 60 3_133.3	133.3	1.1	2.6	2.5	3.9	3.9	5.2	5.2	20	79	77	22	
A 60 3_144.0	144.0	0.80	2.3	2.2	3.7	3.6	5.0	5.0	—	—	—	22	
A 60 3_156.0	156.0	0.80	2.3	2.2	3.7	3.6	5.0	5.0	—	—	—	22	
A 60 3_171.5	171.5	0.60	2.1	2.0	3.5	3.4	4.7	4.7	—	—	—	22	
A 60 3_185.8	185.8	0.60	2.1	2.0	3.5	3.4	4.7	4.7	—	—	—	22	

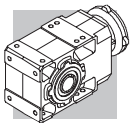
Per i valori dei momenti d'inerzia relativi ai riduttori a 4 stadi, consultare il ns. Servizio Tecnico.
 For the values of the moment of inertia of 4-stage gearboxes, please contact our Technical Service department.
 Im Hinblick auf die Trägheitsmomente der 4-stufigen Getriebe verweisen wir auf unseren Technischen Dienst.
 Quant aux valeurs des moments d'inertie, se référant aux réducteurs à 4 étages, consultez notre Service technique.





A 70

	i	J ($\cdot 10^{-4}$) [kgm ²]											
			 IEC										
			80	90	100	112	132	160	180	200	225	250	
A 70 3_9.4	9.4	—	—	—	—	—	—	187	185	194	—	—	150
A 70 3_10.2	10.2	—	—	—	—	—	—	183	180	190	—	—	146
A 70 3_12.1	12.1	—	—	—	—	—	—	150	148	157	—	—	113
A 70 3_13.1	13.1	—	—	—	—	—	—	147	145	154	—	—	111
A 70 3_15.4	15.4	45	—	—	—	—	64	124	121	161	—	—	87
A 70 3_16.7	16.7	44	—	—	—	—	63	122	120	129	—	—	85
A 70 3_19.7	19.7	30	—	—	—	—	49	109	107	—	—	—	72
A 70 3_21.3	21.3	29	—	—	—	—	48	108	106	—	—	—	71
A 70 3_23.5	23.5	—	—	—	—	—	—	116	114	123	—	—	79
A 70 3_27.8	27.8	—	—	—	—	—	—	118	116	125	—	—	81
A 70 3_30.1	30.1	—	—	—	—	—	—	117	115	124	—	—	81
A 70 3_35.4	35.4	26	—	—	—	—	45	104	102	111	—	—	67
A 70 3_38.4	38.4	25	—	—	—	—	44	104	101	111	—	—	67
A 70 3_45.2	45.2	18	—	—	—	—	37	97	94	—	—	—	59
A 70 3_49.0	49.0	18	—	—	—	—	37	96	94	—	—	—	59
A 70 3_53.2	53.2	15	—	—	—	—	34	93	91	—	—	—	56
A 70 3_57.7	57.7	15	—	—	—	—	34	93	91	—	—	—	56
A 70 3_66.9	66.9	9.7	12	12	13	13	29	88	86	—	—	—	51
A 70 3_72.5	72.5	9.6	12	12	13	13	28	88	86	—	—	—	51
A 70 3_79.3	79.3	6.8	9.4	9.3	11	11	26	85	83	—	—	—	48
A 70 3_85.9	85.9	6.7	9.3	9.3	11	11	26	85	83	—	—	—	48
A 70 3_96.2	96.2	5.4	8.2	8.2	9.4	9.4	24	84	82	—	—	—	47
A 70 3_104.2	104.2	5.4	8.2	8.1	9.4	9.4	24	84	81	—	—	—	47
A 70 3_120.6	120.6	3.4	6.2	6.2	7.5	7.5	22	82	79	—	—	—	45
A 70 3_130.7	130.7	3.4	6.2	6.2	7.4	7.4	22	82	79	—	—	—	45
A 70 3_141.9	141.9	2.4	5.3	5.2	6.5	6.5	21	81	78	—	—	—	44
A 70 3_153.7	153.7	2.4	5.2	5.2	6.5	6.5	21	81	78	—	—	—	44

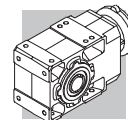
Per i valori dei momenti d'inerzia relativi ai riduttori a 4 stadi, consultare il ns. Servizio Tecnico.
 For the values of the moment of inertia of 4-stage gearboxes, please contact our Technical Service department.
 Im Hinblick auf die Trägheitsmomente der 4-stufigen Getriebe verweisen wir auf unseren Technischen Dienst.
 Quant aux valeurs des moments d'inertie, se référant aux réducteurs à 4 étages, consultez notre Service technique.



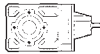

A 80

	i	J ($\cdot 10^{-4}$) [kgm ²]											
			 IEC										
			80	90	100	112	132	160	180	200	225	250	
A 80 3_9.8	9.8	—	—	—	—	—	—	—	320	333	611	—	286
A 80 3_10.7	10.7	—	—	—	—	—	—	—	309	323	601	—	276
A 80 3_12.3	12.3	—	—	—	—	—	—	239	239	253	531	—	205
A 80 3_13.3	13.3	—	—	—	—	—	—	232	233	246	524	—	199
A 80 3_15.5	15.5	—	—	—	—	—	—	187	185	194	478	—	150
A 80 3_16.7	16.7	—	—	—	—	—	—	183	180	190	474	—	150
A 80 3_19.3	19.3	69	—	—	—	—	88	147	145	154	440	—	111
A 80 3_20.9	20.9	66	—	—	—	—	85	145	142	152	437	—	108
A 80 3_22.6	22.6	—	—	—	—	—	—	—	205	219	496	—	171
A 80 3_24.5	24.5	—	—	—	—	—	—	—	203	217	494	—	169
A 80 3_28.2	28.2	—	—	—	—	—	—	165	166	179	457	—	132
A 80 3_30.6	30.6	—	—	—	—	—	—	164	164	178	456	—	130
A 80 3_35.5	35.5	—	—	—	—	—	—	140	138	147	432	—	104
A 80 3_38.5	38.5	—	—	—	—	—	—	140	137	147	431	—	103
A 80 3_44.5	44.5	39	—	—	—	—	58	118	115	125	410	—	81
A 80 3_48.2	48.2	39	—	—	—	—	58	117	115	124	410	—	90
A 80 3_55.2	55.2	29	—	—	—	—	48	108	105	136	399	—	70
A 80 3_59.8	59.8	29	—	—	—	—	48	107	105	136	399	—	70
A 80 3_66.8	66.8	22	—	—	—	—	41	101	98	128	391	—	63
A 80 3_72.4	72.4	22	—	—	—	—	41	100	98	128	391	—	63
A 80 3_82.3	82.3	15	17	17	18	18	34	94	91	120	384	—	56
A 80 3_89.2	89.2	15	17	17	18	18	34	93	91	120	386	—	56
A 80 3_96.0	96.0	14	16	16	17	17	32	92	90	119	382	—	55
A 80 3_104.0	104.0	13	16	16	17	17	32	92	89	119	382	—	55
A 80 3_116.0	116.0	9.1	12	12	13	13	28	87	85	—	—	—	50
A 80 3_125.6	125.6	9.1	12	12	13	13	28	87	85	—	—	—	50
A 80 3_144.7	144.7	5.4	8.3	8.2	10	10	24	84	82	—	—	—	47
A 80 3_156.8	156.8	5.4	3.0	2.9	4.2	4.2	19	78	76	—	—	—	41

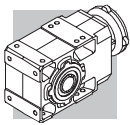
Per i valori dei momenti d'inerzia relativi ai riduttori a 4 stadi, consultare il ns. Servizio Tecnico.
 For the values of the moment of inertia of 4-stage gearboxes, please contact our Technical Service department.
 Im Hinblick auf die Trägheitsmomente der 4-stufigen Getriebe verweisen wir auf unseren Technischen Dienst.
 Quant aux valeurs des moments d'inertie, se référant aux réducteurs à 4 étages, consultez notre Service technique.



A 90

	i	J ($\cdot 10^{-4}$) [kgm ²]												
			 IEC											
			80	90	100	112	132	160	180	200	225	250		
A 90 3_9.7	9.7	—	—	—	—	—	—	—	—	597	611	889	918	898
A 90 3_10.5	10.5	—	—	—	—	—	—	—	—	575	589	867	896	876
A 90 3_12.6	12.6	—	—	—	—	—	—	—	—	402	416	693	723	703
A 90 3_13.7	13.7	—	—	—	—	—	—	—	—	389	403	681	710	690
A 90 3_15.6	15.6	—	—	—	—	—	—	—	—	306	319	597	627	607
A 90 3_16.9	16.9	—	—	—	—	—	—	—	—	297	311	589	618	598
A 90 3_19.4	19.4	—	—	—	—	—	—	—	236	234	243	527	559	530
A 90 3_21.0	21.0	—	—	—	—	—	—	—	231	228	238	522	553	524
A 90 3_22.3	22.3	—	—	—	—	—	—	—	—	326	340	618	647	627
A 90 3_24.1	24.1	—	—	—	—	—	—	—	—	322	336	614	643	623
A 90 3_29.1	29.1	—	—	—	—	—	—	—	—	243	257	535	564	544
A 90 3_31.5	31.5	—	—	—	—	—	—	—	—	241	254	532	562	542
A 90 3_35.8	35.8	—	—	—	—	—	—	—	—	201	215	493	522	502
A 90 3_38.8	38.8	—	—	—	—	—	—	—	—	200	213	491	521	500
A 90 3_44.6	44.6	—	—	—	—	—	—	—	169	166	176	460	491	462
A 90 3_48.3	48.3	—	—	—	—	—	—	—	168	165	175	459	490	461
A 90 3_55.0	55.0	66	—	—	—	—	—	85	144	142	151	437	468	438
A 90 3_59.6	59.6	66	—	—	—	—	—	84	144	141	151	436	468	437
A 90 3_68.8	68.8	48	—	—	—	—	—	67	126	124	154	418	449	416
A 90 3_74.5	74.5	47	—	—	—	—	—	66	126	123	154	417	449	416
A 90 3_80.4	80.4	43	—	—	—	—	—	62	121	119	149	412	443	412
A 90 3_87.1	87.1	43	—	—	—	—	—	62	121	119	148	412	443	412
A 90 3_98.6	98.6	28	30	30	32	32	47	106	106	104	134	397	428	399
A 90 3_106.8	106.8	28	30	30	31	31	47	106	106	104	133	397	428	399
A 90 3_116.9	116.9	23	25	25	26	26	41	101	101	99	128	391	423	394
A 90 3_126.6	126.6	22	25	25	26	26	41	101	101	98	128	391	422	394
A 90 3_139.4	139.4	15	17	17	19	19	33	93	93	91	—	—	—	386
A 90 3_151.0	151.0	14	3.0	3.0	4.3	4.3	19	79	79	76	—	—	—	372

Per i valori dei momenti d'inerzia relativi ai riduttori a 4 stadi, consultare il ns. Servizio Tecnico.
 For the values of the moment of inertia of 4-stage gearboxes, please contact our Technical Service department.
 Im Hinblick auf die Trägheitsmomente der 4-stufigen Getriebe verweisen wir auf unseren Technischen Dienst.
 Quant aux valeurs des moments d'inertie, se référant aux réducteurs à 4 étages, consultez notre Service technique.

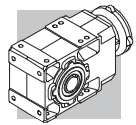

33 - RAPPORTI ESATTI

33 - EXACT RATIOS

33 - EXAKTE ÜBERSETZUNG

33 - RAPPORTS EXACTS

iN	A 05	A 10	A 20	A 30	A 35	A 41	A 50	A 55	A 60	A 70	A 80	A 90
5.0								4.94505				
5.6	5.46559	5.46559	5.35117	5.41311	5.41311	5.24476						
6.3	6.33484	6.33484	6.53846	6.41026	6.41026			6.41026				
7.1	7.21154	7.21154	7.28745	7.02341	7.02341	7.12251						
8.0	8.51648	8.51648	8.37104	8.46154	8.46154	8.33333	7.73684	8.46154	7.86420			
9.0	9.61538	9.61538	9.37500	9.31174	9.31174	9.19732				9.43946		9.67545
10.0	10.55639	10.55639	10.33540	10.45503	10.63348	10.12987	9.73401	10.35503	10.31579	10.22609	9.83278	10.48174
11.2				11.77885	11.77885	11.74089				12.08027	10.65217	12.64214
12.5	12.30769	12.30769	11.96581		13.06878		13.10700	13.07692	12.70370	13.08696	12.27130	13.69565
14.0	13.92857	13.92857	14.07519	13.56522	15.47619	13.75661				15.40468	13.29391	15.57512
16.0	16.44898	16.44898	16.16807	16.34286	16.95652	16.09524	16.57005	15.68047	16.73663	16.68841	15.45151	16.87304
18.0	18.57143	18.57143	18.10714	17.98496		17.76398					19.33779	19.38462
20.0	21.35714	21.35714	21.22449	20.53782	20.42857		20.91813	19.23077	20.5942	19.66555	20.94928	21.00000
22.4	23.77143	23.77143	23.11111	22.75000	22.48120	22.67669				21.30435	22.61538	22.25354
25.0	25.46939	25.46939	26.46429	26.53061	25.67227		24.04795	23.79021	25.71012	23.52000	24.50000	24.10800
28.0	28.57143	28.57143	29.21905	29.30159	28.43750	28.32143	26.43733		27.85263	27.78462	28.22400	29.07692
31.5	32.19048	32.19048	31.30612	33.42857	33.16327		32.38095	29.93134	31.66154	30.10000	30.57600	31.50000
35.5	35.11688	35.11688	35.42857	36.64762	36.62698	35.90476	35.59829		34.30000	35.43077	35.53846	35.82277
40.0	40.85714	40.85714	39.61905	39.26531	41.78571	45.06667	40.93645	40.30303	41.71282	38.38333	38.50000	38.80800
45.0	45.39683	45.39683	43.22078	43.42857	45.80952	48.28571	45.00386		45.18889	45.23077	44.47692	44.58462
50.0	51.25714	51.25714	48.28571	48.28571	49.08163	53.14286	51.67843	50.95166	51.32709	49.00000	48.18333	48.30000
56.0	58.60317	58.60317	53.65079	52.67532	54.28571	58.80952	56.81314		55.60435	53.23314	55.18154	55.03077
63.0	65.92857	65.92857	63.14286	59.42857	60.35714	64.15584	63.89011	64.32168	64.98947	66.94154	66.80237	59.61667
71.0			70.98413	66.03175	65.84416	71.31429	70.23817		70.40526	72.52000	72.36923	68.75077
80.0	76.40816	76.40816	79.85714	76.51429	74.28571	79.23810	81.45055	79.52098	79.71923	79.32781	82.32000	80.37160
90.0	91.61905	91.61905	92.32653	86.66667	82.53968	92.76828	89.54339		86.36250	85.93846	89.18000	87.06923
100.0				97.50000	95.64286		99.53407	101.37762	99.50769	96.21818	104.03077	98.60308
112.2			109.16518	109.07029	105.54155	115.86039	109.42367	123.88531	107.80000	104.23636	115.95524	116.90414
125.0			120.52857	120.46208	116.90972		129.67046	132.73427	123.02769	120.61538	125.61818	126.64615
140.0			146.14286	137.42857	136.33787	146.88312	140.61938	146.80796	144.04260	141.86014	144.73846	139.39301
160.0			163.42857	161.42404	150.57760		154.59118	160.43706	171.46573	169.75499	156.80000	166.12694
180.0			178.28571	178.53968	171.78571	184.36364	173.36264	175.02225	185.75455	183.90123	171.29752	179.97085
200.0			199.17857	198.50794	201.78005	197.53247	190.58777	194.19860	208.73017		214.73193	209.01044
225.0			221.30952	216.55411	223.17460	217.40260	231.98700	208.05260	226.12435	220.25418	232.62626	226.42797
250.0			260.46429	244.31746	248.13492	240.58442	260.88462		264.29053	238.60870		
280.0			292.80952	271.46384	270.69264	291.74026	286.80584	262.64685	286.31474	292.01619	277.28428	281.43590
315.0			329.41071	314.55873	305.39683	324.15584	332.58974		324.19154	316.35088	300.39130	304.88889
355.0				356.29630	339.32981	376.83117	365.63552	324.71066	351.20750	369.38462	353.96864	355.79521
400.0			380.84694	400.83333	393.19841		406.43077		404.66462	400.16667	383.46603	385.44482
450.0							446.81331	413.95862	438.38667	475.76068	442.07937	449.15802
500.0							481.63314	505.86503	500.31262	515.40741	478.91932	486.58785
560.0							574.19580	541.99825	585.77325	595.03590	560.45035	555.29467
630.0							631.24731	655.11801	634.58769	644.62222	607.15455	601.56923
710.0							707.89744	714.67419	697.29399	705.13609	703.46182	707.91953
800.0							778.23340	792.97762	755.40182	855.27273	829.52598	766.91282
900.0										926.54545	898.65315	865.09065
1000.0										1072.13675	1001.43166	1025.1594
1125.0										1161.48148	1084.88430	1110.58935
1250.0										1242.33846	1236.85594	1222.17967
1400.0										1345.86667	1339.92727	1324.02797
1600.0										1583.07692	1557.66545	1506.76450
1800.0										1715.00000		1632.32821



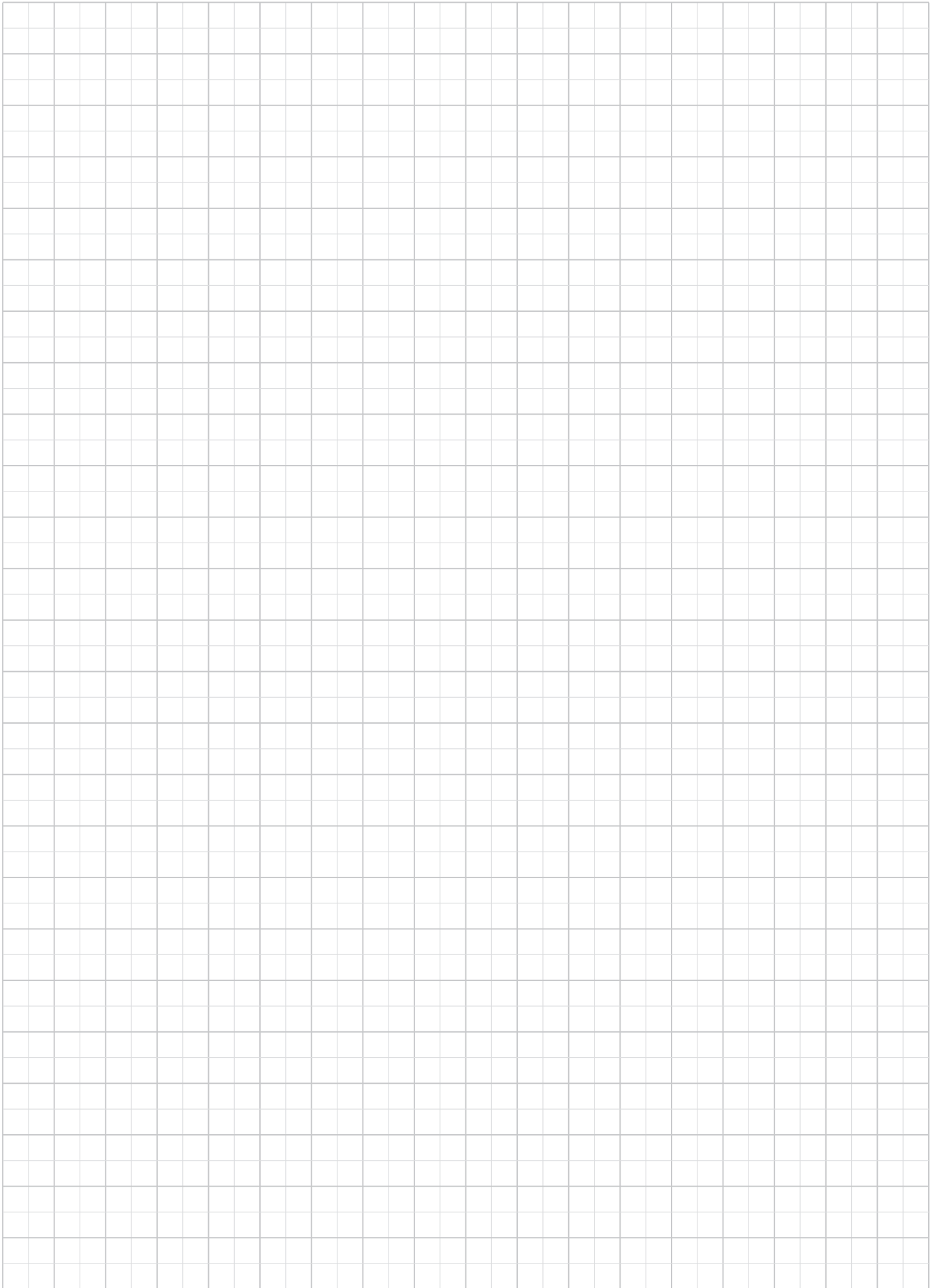
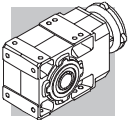

A 05...M

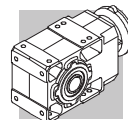

34 - DIMENSIONI

34 - DIMENSIONS

34 - ABMESSUNGEN

34 - DIMENSIONS

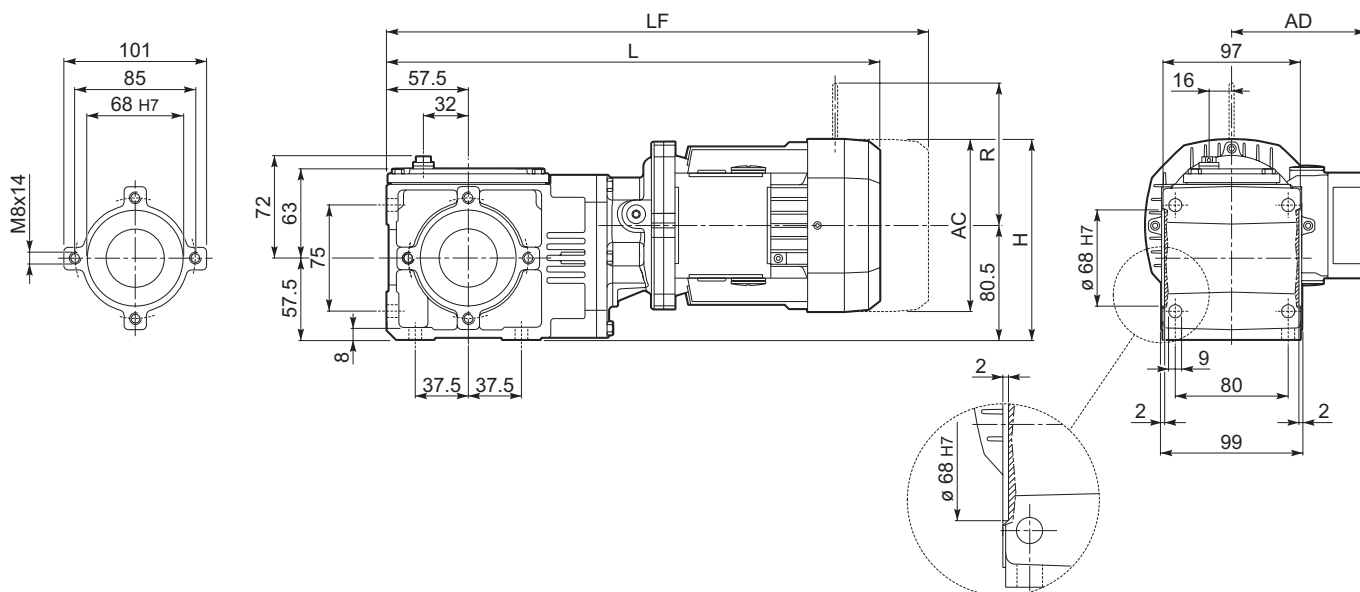

	AC	H	L	AD	Kg	M_FD M_FA		M_FD		M_FA	
						LF	Kg	R	AD	R	AD
A 05 2 S05 M05	121	141	360.5	95	7.5	426.5	9	96	122	116	95
A 05 2 S1 M1	138	149.5	389.5	108	11.5	450.5	14	103	135	124	108
A 05 2 S2 M2S	156	158.5	418.5	119	15.5	488.5	19	129	146	134	119

A 05...P(IEC)

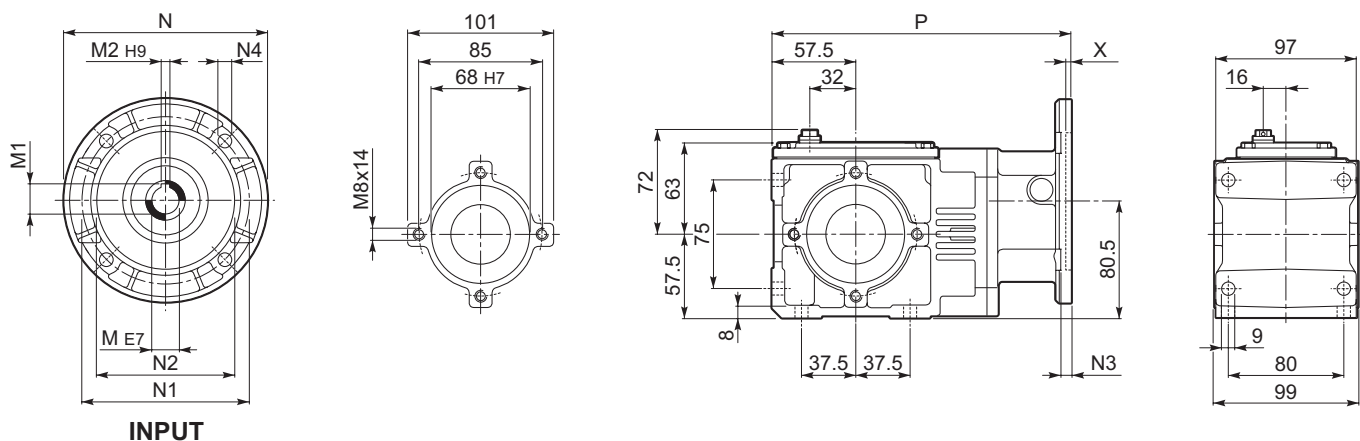

	M	M1	M2	N	N1	N2	N3	N4	X	P	Kg
A 05 2 P71	14	16.3	5	160	130	110	7	9.5	4	213	5
A 05 2 P80	19	20.8#	6	200	165	130	7	11.5	4	223	5.5

Linguetta di tipo ribassato di fornitura Bonfiglioli

Lowered key of Bonfiglioli supply

Verkleinerte Feder, gelieferte von Bonfiglioli.

Clavette de type rabaissé de fourniture Bonfiglioli

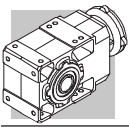

A 05...SK / SC

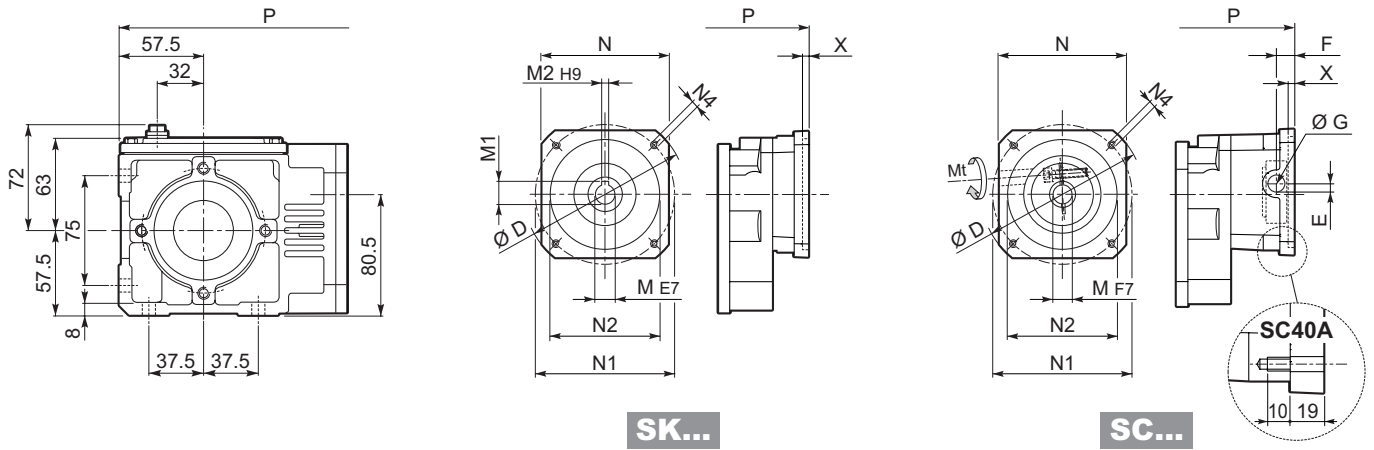

SK...

SC...

		D	M	M1	M2	N	N1	N2	N4	X	P	
A 05 2	SK40A	74	9	10.4	3	55	63	40	M5x10	3	207.5	5
A 05 2	SK60A	102	11	12.8	4	82	75	60	M5x10	3.5	206	5
A 05 2	SK60B	102	14	16.3	5	82	75	60	M5x10	4	213	5
A 05 2	SK80A	115	14	16.3	5	90	100	80	M6x12	4	213	5

			Mt	D	E	F	G	M	N	N1	N2	N4	X	P	
A 05 2	SC40A	M5	15 Nm	74	10.5	9.5	12.5	9	55	63	40	M5x10	3	226.5	6
A 05 2	SC60A	M6	15 Nm	102	7	12.5	12.5	11	82	75	60	M5x10	4	233	6
A 05 2	SC60B	M6	15 Nm	102	7	12.5	12.5	14	82	75	60	M5x10	4	233	6
A 05 2	SC80A	M6	15 Nm	115	6	12.5	12.5	14	90	100	80	M6x12	4	233	6

A 05...F...

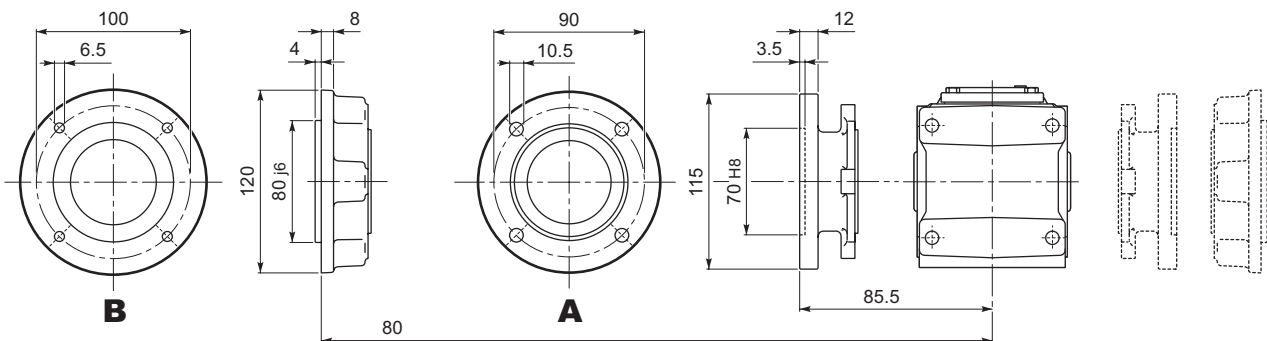

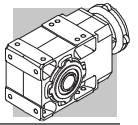

A 05...UH

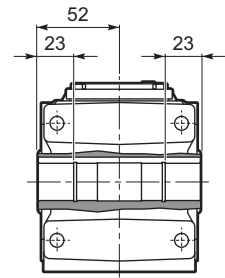
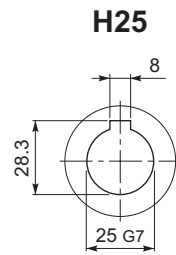



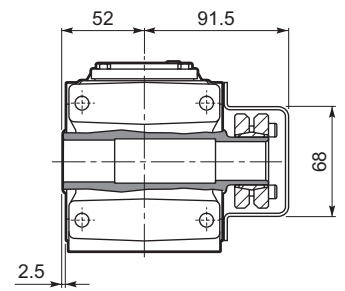
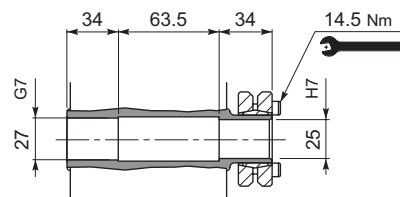

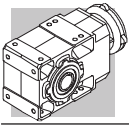
A 05...US



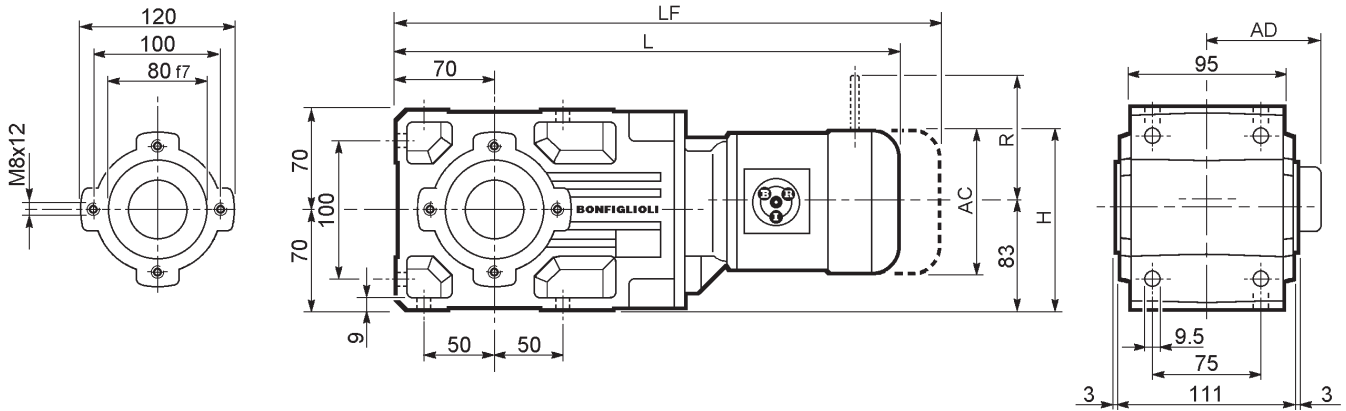

A 10...M



  	AC	H	L	AD	Kg	M_FD M_FA		M_FD		M_FA	
						LF	Kg	R	AD	R	AD
A 10 2 S05 M05	121	143.5	408.5	95	12	474.5	14	96	122	116	95
A 10 2 S1 M1	138	152	437.5	108	14	498.5	17	103	135	124	108
A 10 2 S2 M2S	156	161	466.5	119	18	536.5	22	129	146	134	119
A 10 2 S3 M3S	195	180.5	509.5	142	23	605.5	30	160	158	160	142
A 10 2 S3 M3L	195	180.5	541.5	142	30	632.5	37	160	158	160	142

A 10...P(IEC)

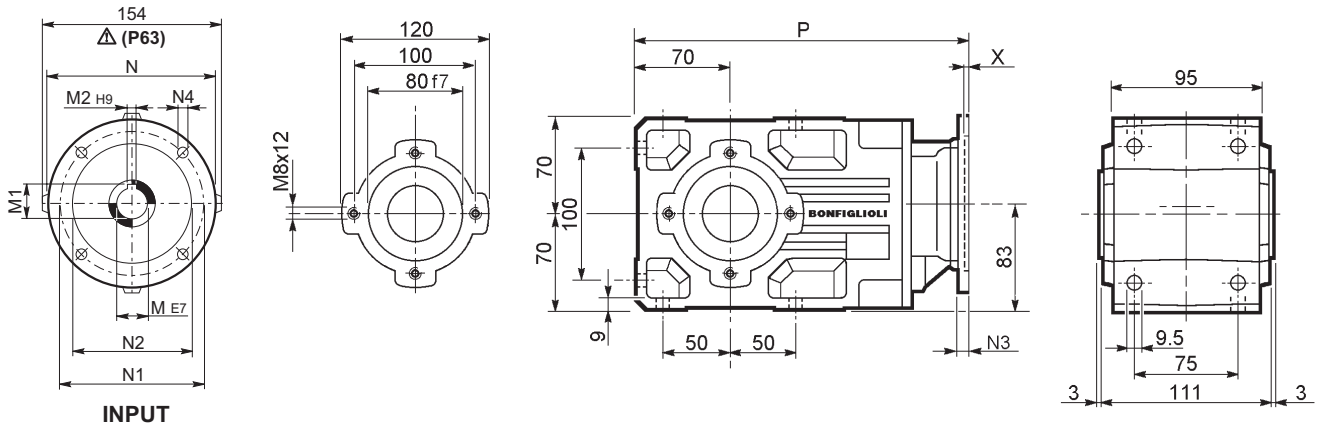
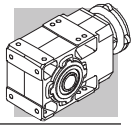

INPUT

		M	M1	M2	N	N1	N2	N3	N4	X	P	Kg		
		A 10 2	P63	11	12.8	4	140	115	95	—	M8x10	4	282.5	8
A 10 2	P71	14	16.3	5	160	130	110	—	M8x10	4.5	282.5	9		
A 10 2	P80	19	21.8	6	200	165	130	—	M10x12	4	302	9		
A 10 2	P90	24	27.3	8	200	165	130	—	M10x12	4	302	9		
A 10 2	P100	28	31.3	8	250	215	180	—	M12x16	4.5	312	13		
A 10 2	P112	28	31.3	8	250	215	180	—	M12x16	4.5	312	13		

A 10...HS

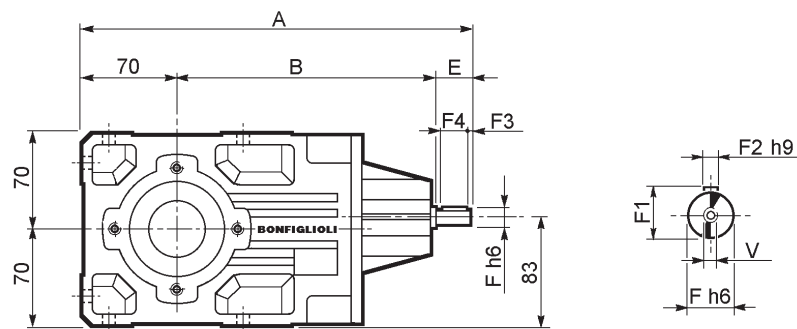

		A	B	E	F	F1	F2	F3	F4	V	Kg		
		A 10 2	HS	289.5	179.5	40	16	18	5	2.5	35	M6x16	7.8

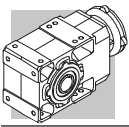

A 10...SK / SC

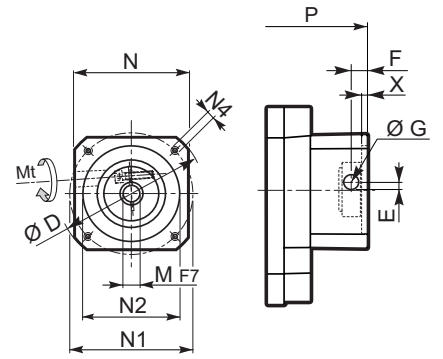
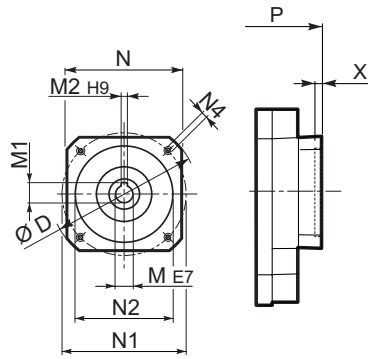
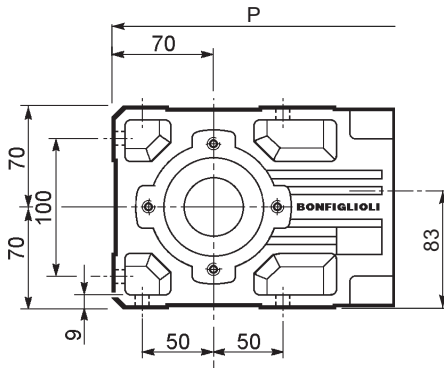

SK...

SC...

		D	M	M1	M2	N	N1	N2	N4	X	P	Kg
		102	11	12.8	4	82	75	60	M5x10	3.5	254	8
		102	14	16.3	5	82	75	60	M5x10	4	261	8
		115	14	16.3	5	90	100	80	M6x12	4	261	8
		120	19	21.8	6	96	100	80	M6x12	4	302	9
		130	14	16.3	5	102	115	95	M8x12	4	302	9
		130	19	21.8	6	102	115	95	M8x12	4	302	9
		130	24	27.3	8	102	115	95	M8x12	4	302	9
		150	19	21.8	6	120	130	110	M8x12	5	302	9
		150	24	27.3	8	120	130	110	M8x12	5	302	9

		Mt	D	E	F	G	M	N	N1	N2	N4	X	P	Kg
		M6 15 Nm	102	7	12.5	12.5	11	82	75	60	M5x10	4	281	9
		M6 15 Nm	102	7	12.5	12.5	14	82	75	60	M5x10	4	281	9
		M6 15 Nm	115	6	12.5	12.5	14	90	100	80	M6x12	4	281	9
		M6 15 Nm	120	15.5	14.5	17.75	19	96	100	80	M6x12	4	325.5	10
		M6 15 Nm	130	16.5	15	17.75	14	102	115	95	M8x16	4	325.5	10
		M6 15 Nm	130	16.5	15	17.75	19	102	115	95	M8x16	4	325.5	10
		M6 15 Nm	130	16.5	15	17.75	24	102	115	95	M8x16	4	325.5	10
		M6 15 Nm	150	16.5	16	17.75	19	120	130	110	M8x16	5	325.5	12
		M6 15 Nm	150	16.5	16	17.75	24	120	130	110	M8x16	5	325.5	12

A 10...F...

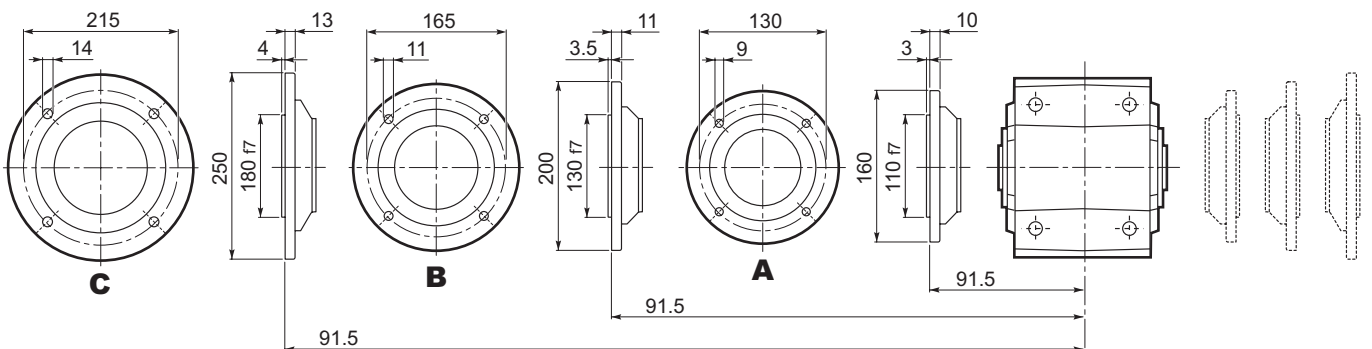

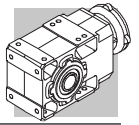

A 10...UR

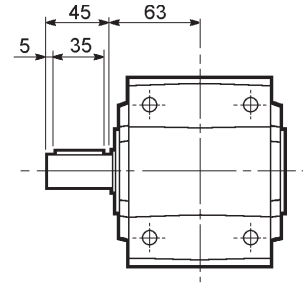
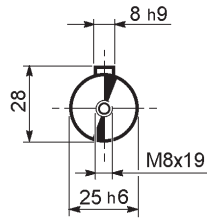

A 10...UD

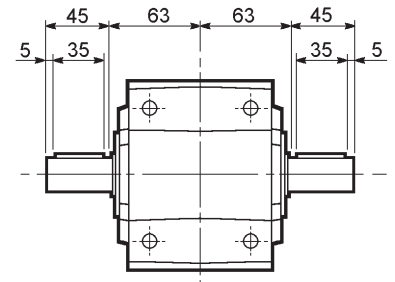
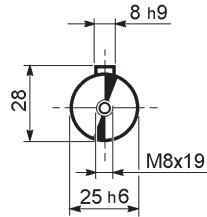

A 10...UH

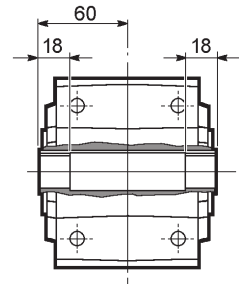
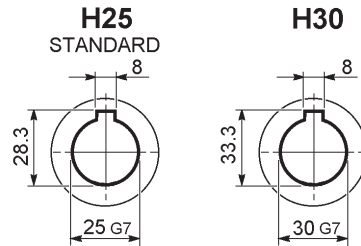

A 10...US

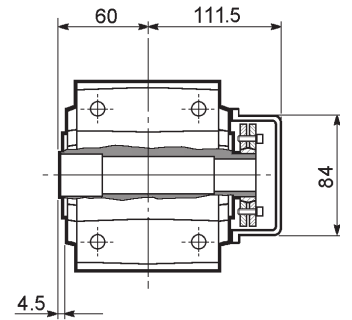
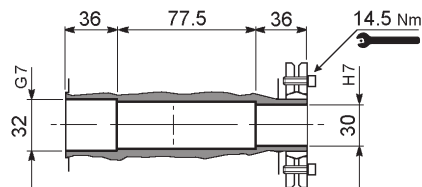

A 10...QF

	Ø
QF25	25
QF30	30

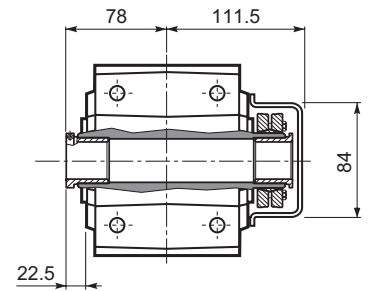
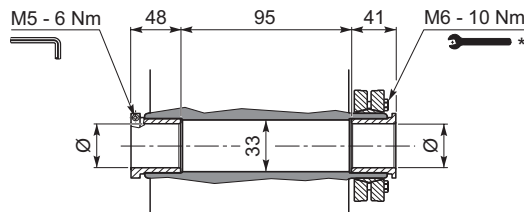

* Attenersi alle ISTRUZIONI PER IL MONTAGGIO fornite con il riduttore.

* Follow the MOUNTING INSTRUCTIONS supplied with the gearbox.



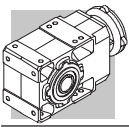

* Befolgen Sie die MONTAGEANLEITUNG die dem Getriebe beiliegt.

* Suivez les INSTRUCTIONS POUR LE MONTAGE fournies avec le réducteur.

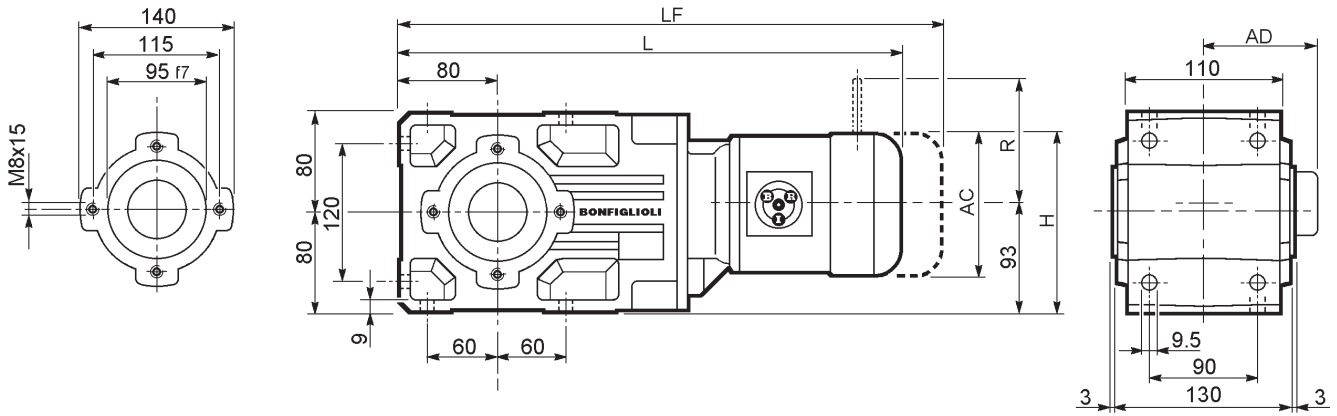

A 20...M



  								M_FD M_FA		M_FD		M_FA	
	AC	H	L	AD	 Kg	LF	 Kg	R	AD	R	AD		
A 20 2 S05 M05	121	143.5	432	95	16	498	18	96	122	116	95		
A 20 2 S1 M1	138	152	461	108	18	522	21	103	135	124	108		
A 20 2 S2 M2S	156	161	490	119	22	560	26	129	146	134	119		
A 20 2 S3 M3S	195	180.5	533	142	27	629	34	160	158	160	142		
A 20 2 S3 M3L	195	180.5	565	142	34	656	41	160	158	160	142		
A 20 3 S05 M05	121	143.5	457.5	95	16	553.5	18	96	122	116	95		
A 20 3 S1 M1	138	152	486.5	108	19	577.5	21	103	135	124	108		
A 20 3 S2 M2S	156	161	545.5	119	23	615.5	27	129	146	134	119		
A 20 3 S3 M3S	195	180.5	588.5	142	28	684.5	35	160	158	160	142		
A 20 3 S3 M3L	195	180.5	620.5	142	35	711.5	42	160	158	160	142		

A 20...P(IEC)

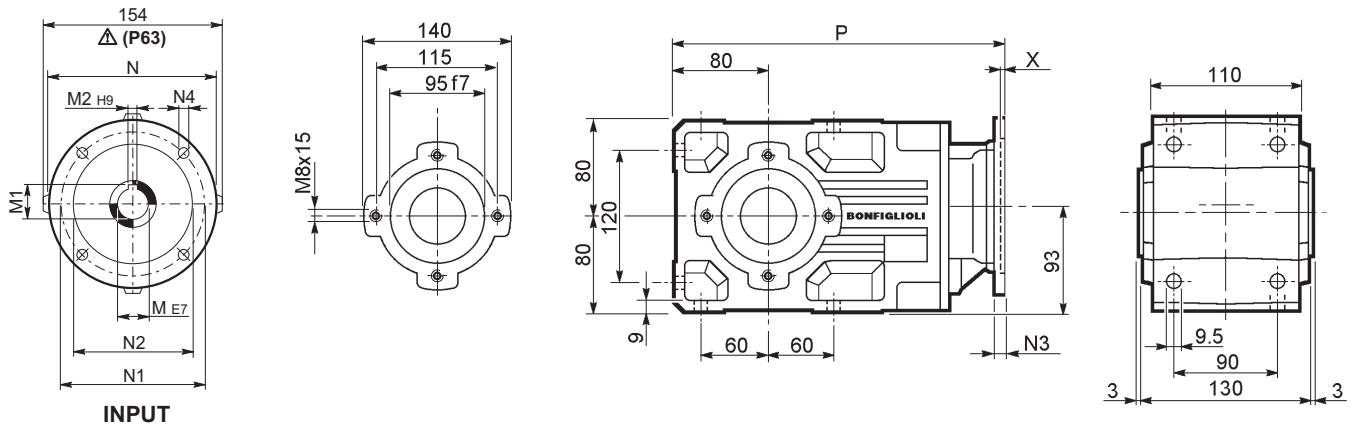
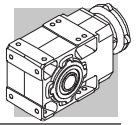

		M	M1	M2	N	N1	N2	N3	N4	X	P			
		A 20 2	P63	11	12.8	4	140	115	95	—	M8x19	4	306	12
		A 20 2	P71	14	16.3	5	160	130	110	—	M8x16	4.5	306	12
		A 20 2	P80	19	21.8	6	200	165	130	—	M10x12	4	325.5	13
		A 20 2	P90	24	27.3	8	200	165	130	—	M10x12	4	325.5	13
		A 20 2	P100	28	31.3	8	250	215	180	—	M12x16	4.5	335.5	17
		A 20 2	P112	28	31.3	8	250	215	180	—	M12x16	4.5	335.5	17
		A 20 3	P63	11	12.8	4	140	115	95	—	M8x19	4	361.5	13
		A 20 3	P71	14	16.3	5	160	130	110	—	M8x16	4.5	361.5	13
		A 20 3	P80	19	21.8	6	200	165	130	—	M10x12	4	381	14
		A 20 3	P90	24	27.3	8	200	165	130	—	M10x12	4	381	14
		A 20 3	P100	28	31.3	8	250	215	180	—	M12x16	4.5	391	18
		A 20 3	P112	28	31.3	8	250	215	180	—	M12x16	4.5	391	18

A 20...HS

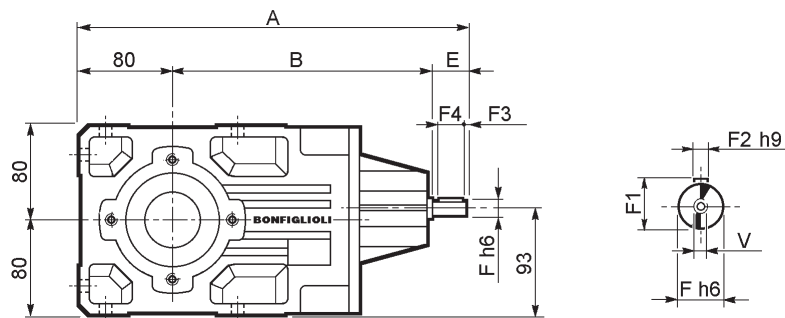

		A	B	E	F	F1	F2	F3	F4	V			
		A 20 2	HS	356	236	40	19	21.5	6	2.5	35	M6x16	11.9
		A 20 3	HS	368.5	248.5	40	16	18	5	2.5	35	M6x16	12.2

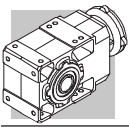

A 20...SK / SC

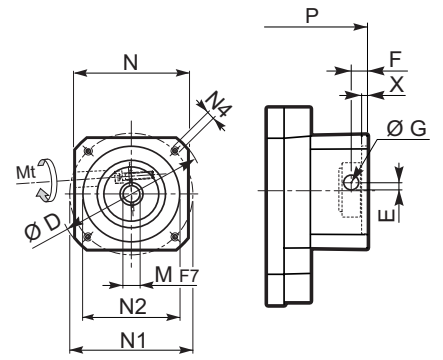
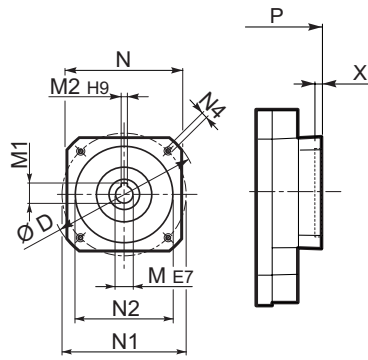
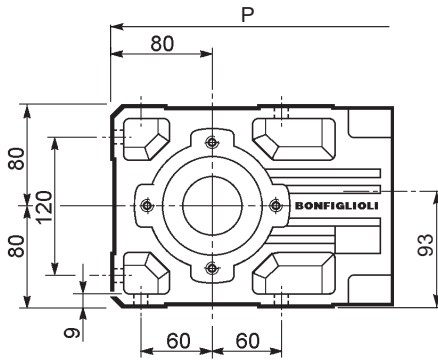

SK...

SC...

		D	M	M1	M2	N	N1	N2	N4	X	P		Kg
											2x	3x	
A 20 2/3	SK60A	102	11	12.8	4	82	75	60	M5x10	3.5	277.5	333	11/12
A 20 2/3	SK60B	102	14	16.3	5	82	75	60	M5x10	4	284.5	340	12/13
A 20 2/3	SK80A	115	14	16.3	5	90	100	80	M6x12	4	284.5	340	12/13
A 20 2/3	SK80C	120	19	21.8	6	96	100	80	M6x12	4	325.5	381	13/14
A 20 2/3	SK95A	130	14	16.3	5	102	115	95	M8x12	4	325.5	381	13/14
A 20 2/3	SK95B	130	19	21.8	6	102	115	95	M8x12	4	325.5	381	13/14
A 20 2/3	SK95C	130	24	27.3	8	102	115	95	M8x12	4	325.5	381	13/14
A 20 2/3	SK110A	150	19	21.8	6	120	130	110	M8x12	5	325.5	381	13/14
A 20 2/3	SK110B	150	24	27.3	8	120	130	110	M8x12	5	325.5	381	13/14

		Mt	D	E	F	G	M	N	N1	N2	N4	X	P		Kg
													2x	3x	
A 20 2/3	SC60A	M6 15 Nm	102	7	12.5	12.5	11	82	75	60	M5x10	4	304.5	360	12/13
A 20 2/3	SC60B	M6 15 Nm	102	7	12.5	12.5	14	82	75	60	M5x10	4	304.5	360	13/14
A 20 2/3	SC80A	M6 15 Nm	115	6	12.5	12.5	14	90	100	80	M6x12	4	304.5	360	13/14
A 20 2/3	SC80C	M6 15 Nm	120	15.5	14.5	17.75	19	96	100	80	M6x12	4	349	404.5	14/15
A 20 2/3	SC95A	M6 15 Nm	130	16.5	15	17.75	14	102	115	95	M8x16	4	349	404.5	14/15
A 20 2/3	SC95B	M6 15 Nm	130	16.5	15	17.75	19	102	115	95	M8x16	4	349	404.5	14/15
A 20 2/3	SC95C	M6 15 Nm	130	16.5	15	17.75	24	102	115	95	M8x16	4	349	404.5	14/15
A 20 2/3	SC110A	M6 15 Nm	150	16.5	16	17.75	19	120	130	110	M8x16	5	349	404.5	15/16
A 20 2/3	SC110B	M6 15 Nm	150	16.5	16	17.75	24	120	130	110	M8x16	5	349	404.5	15/16

A 20...F...

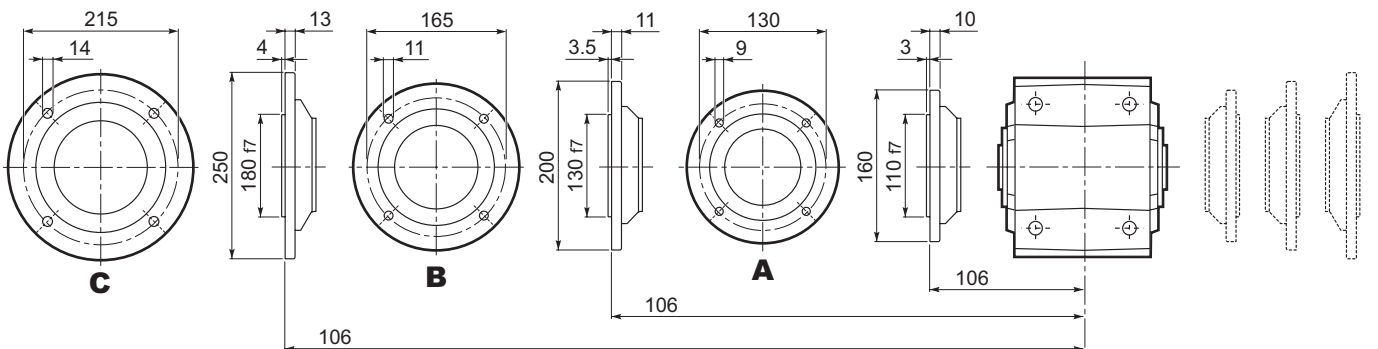

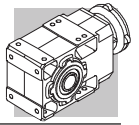

A 20...UR

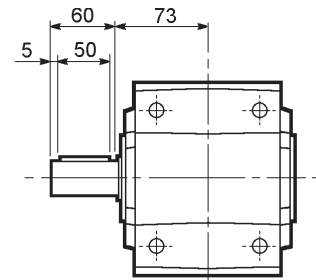
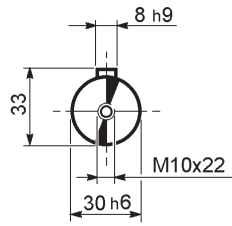

A 20...UD

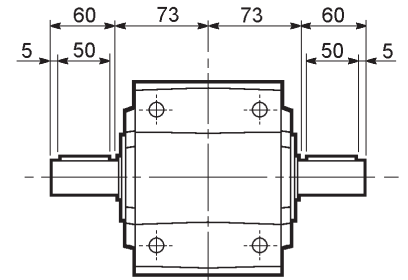
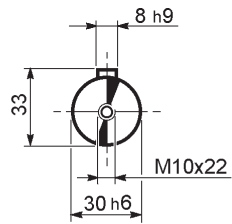

A 20...UH

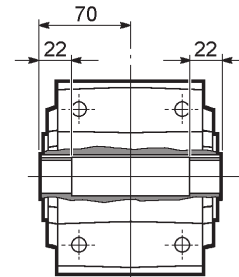
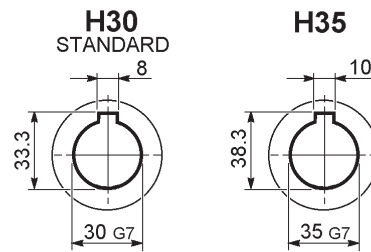

A 20...US

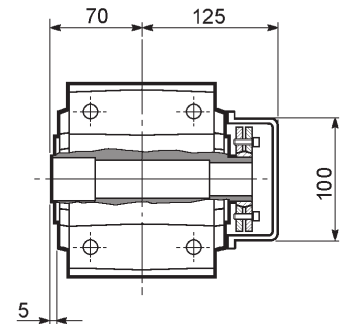
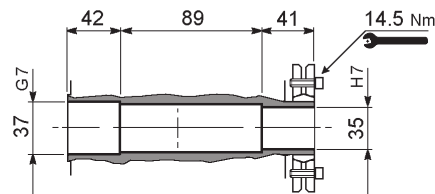

A 20...QF

	Ø
QF25	25
QF30	30

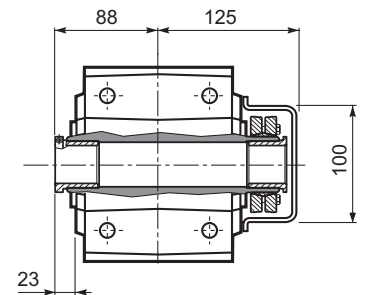
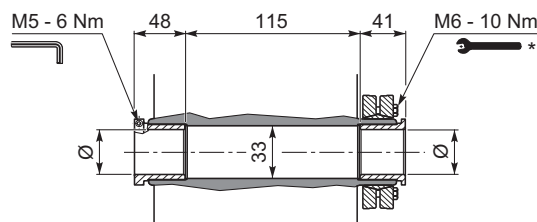

A 20...UV

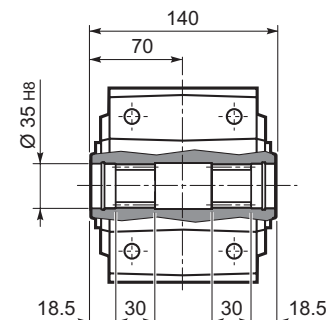

* Attenersi alle ISTRUZIONI PER IL MONTAGGIO fornite con il riduttore.

* Follow the MOUNTING INSTRUCTIONS supplied with the gearbox.

* Befolgen Sie die MONTAGEANLEITUNG die dem Getriebe beiliegt.

* Suivez les INSTRUCTIONS POUR LE MONTAGE fournies avec le réducteur.

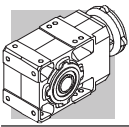

A 30...M

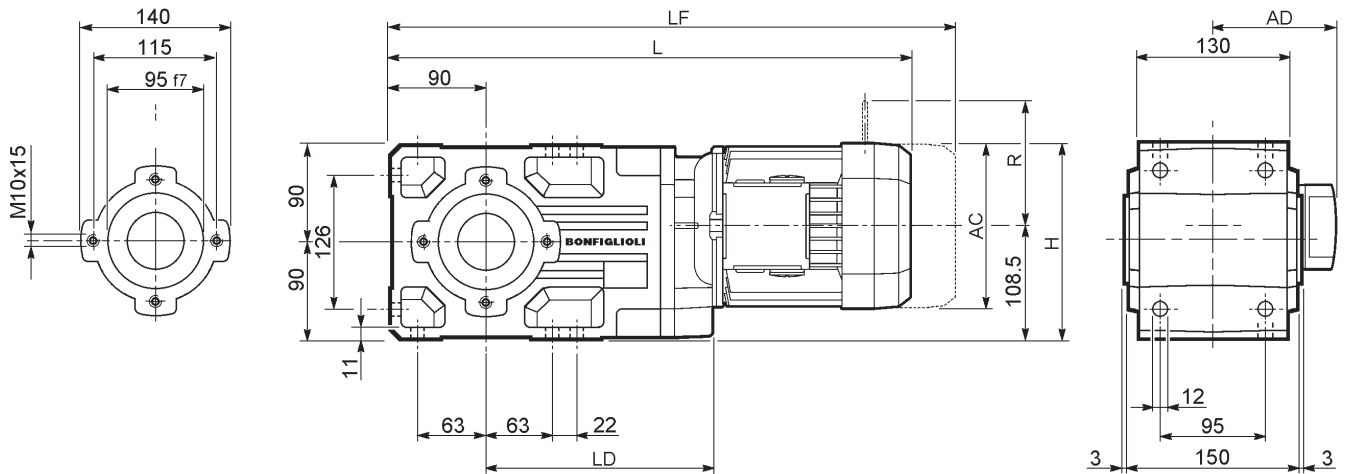

			AC	H	L	LD	AD	Kg	M_FD M_FA		M_FD		M_FA	
									LF	Kg	R	AD	R	AD
A 30 2	S1	M1	138	177.5	488	201	108	22	549	24	103	135	124	108
A 30 2	S2	M2S	156	186.5	517	213	119	25	587	29	129	146	134	119
A 30 2	S3	M3S	195	206	560	223	142	30	656	38	160	158	160	142
A 30 2	S3	M3L	195	206	592	223	142	38	683	45	160	158	160	142
A 30 3	S05	M05	121	169	516.5	—	95	21	582.5	22	96	122	116	95
A 30 3	S1	M1	138	177.5	545.5	—	108	23	606.5	26	103	135	124	108
A 30 3	S2	M2S	156	186.5	574.5	—	119	25	644.5	29	129	146	134	119
A 30 3	S3	M3S	195	206	617.5	—	142	30	713.5	38	160	158	160	142
A 30 3	S3	M3L	195	206	649.5	—	142	38	740.5	45	160	158	160	142

A 30...P(IEC)

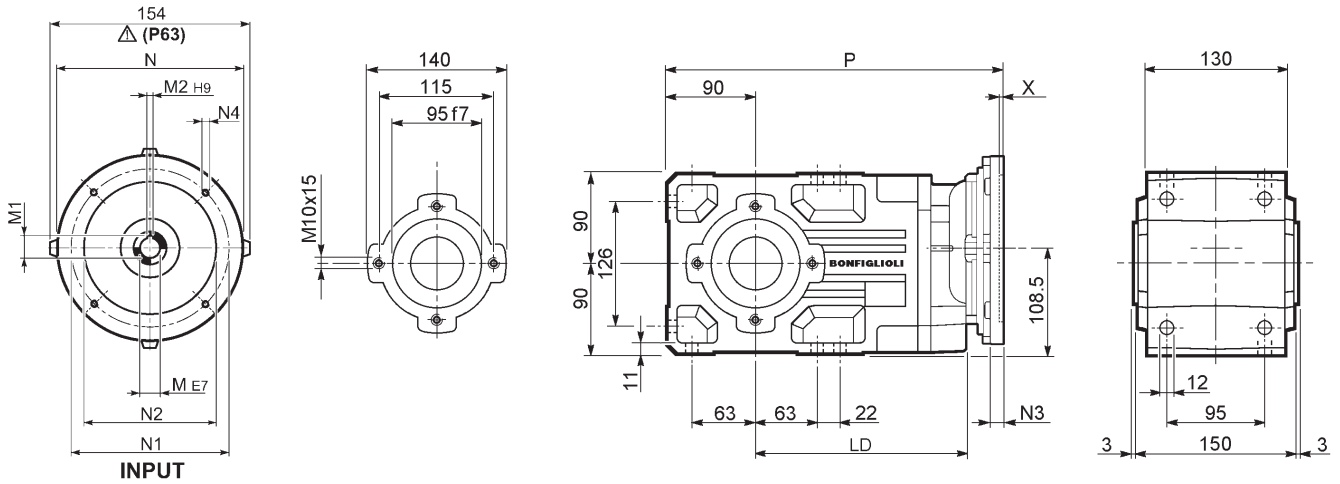
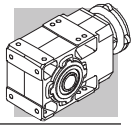

		LD	M	M1	M2	N	N1	N2	N3	N4	X	P	Kg
		213	11	12.8	4	140	115	95	—	M8x19	4	333	16
		213	14	16.3	5	160	130	110	—	M8x16	4.5	333	16
		223	19	21.8	6	200	165	130	—	M10x12	4	352.5	17
		223	24	27.3	8	200	165	130	—	M10x12	4	352.5	17
		223	28	31.3	8	250	215	180	—	M12x16	4.5	362.5	20
		223	28	31.3	8	250	215	180	—	M12x16	4.5	362.5	20
		—	11	12.8	4	140	115	95	—	M8x19	4	390.5	17
		—	14	16.3	5	160	130	110	—	M8x16	4.5	390.5	17
		—	19	21.8	6	200	165	130	—	M10x12	4	410	18
		—	24	27.3	8	200	165	130	—	M10x12	4	410	18
		—	28	31.3	8	250	215	180	—	M12x16	4.5	420	22
		—	28	31.3	8	250	215	180	—	M12x16	4.5	420	22

A 30...HS

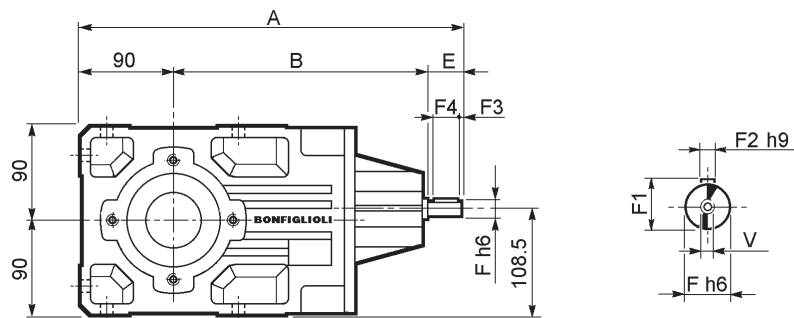

		A	B	E	F	F1	F2	F3	F4	V	Kg
		383	253	40	19	21.5	6	2.5	35	M6x16	16.7
		397.5	267.5	40	16	18	5	2.5	35	M6x16	16.5

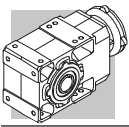

A 30...SK / SC

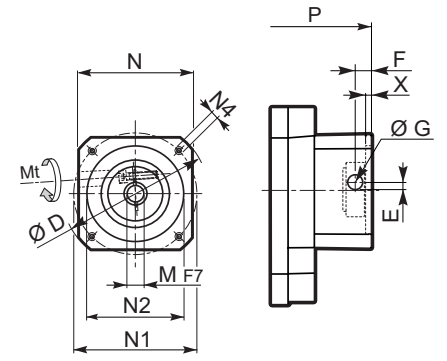
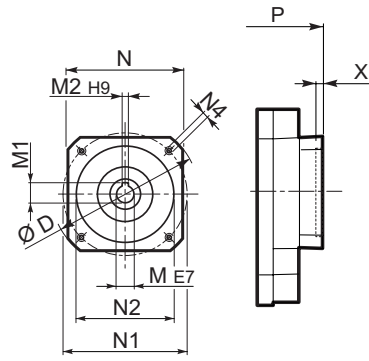
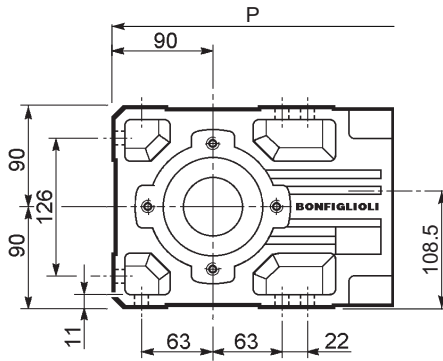

SK...

SC...

		D	M	M1	M2	N	N1	N2	N4	X	P		Kg
											2x	3x	
A30 2/3	SK60A	102	11	12.8	4	82	75	60	M5x10	3.5	304.5	362	15/16
A30 2/3	SK60B	102	14	16.3	5	82	75	60	M5x10	4	311.5	369	16/17
A30 2/3	SK80A	115	14	16.3	5	90	100	80	M6x12	4	311.5	369	16/17
A30 2/3	SK80C	120	19	21.8	6	96	100	80	M6x12	4	352.5	410	17/18
A30 2/3	SK95A	130	14	16.3	5	102	115	95	M8x12	4	352.5	410	17/18
A30 2/3	SK95B	130	19	21.8	6	102	115	95	M8x12	4	352.5	410	17/18
A30 2/3	SK95C	130	24	27.3	8	102	115	95	M8x12	4	352.5	410	17/18
A30 2/3	SK110A	150	19	21.8	6	120	130	110	M8x12	5	352.5	410	17/18
A30 2/3	SK110B	150	24	27.3	8	120	130	110	M8x12	5	352.5	410	17/18
A30 2	SK130A	188	24	27.3	8	142	165	130	M10x20	5	352.5	—	18

		Mt	D	E	F	G	M	N	N1	N2	N4	X	P		Kg
													2x	3x	
A30 2/3	SC60A	M6 15 Nm	102	7	12.5	12.5	11	82	75	60	M5x10	4	331.5	389	16/17
A30 2/3	SC60B	M6 15 Nm	102	7	12.5	12.5	14	82	75	60	M5x10	4	331.5	389	17/18
A30 2/3	SC80A	M6 15 Nm	115	6	12.5	12.5	14	90	100	80	M6x12	4	331.5	389	17/18
A30 2/3	SC80C	M6 15 Nm	120	15.5	14.5	17.75	19	96	100	80	M6x12	4	376	433.5	18/19
A30 2/3	SC95A	M6 15 Nm	130	16.5	15	17.75	14	102	115	95	M8x16	4	376	433.5	18/19
A30 2/3	SC95B	M6 15 Nm	130	16.5	15	17.75	19	102	115	95	M8x16	4	376	433.5	18/19
A30 2/3	SC95C	M6 15 Nm	130	16.5	15	17.75	24	102	115	95	M8x16	4	376	433.5	18/19
A30 2/3	SC 110A	M6 15 Nm	150	16.5	16	17.75	19	120	130	110	M8x16	5	376	433.5	19/20
A30 2/3	SC 110B	M6 15 Nm	150	16.5	16	17.75	24	120	130	110	M8x16	5	376	433.5	19/20
A30 2	SC 130A	M6 15 Nm	188	19	16	17.75	24	142	165	130	M10x20	5	376	—	20

A 30...F...

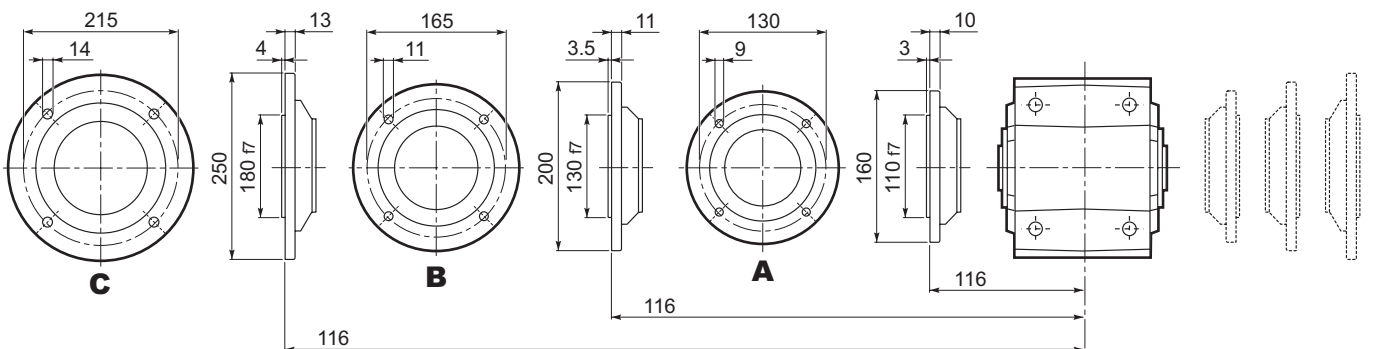

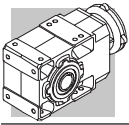

A 35...M

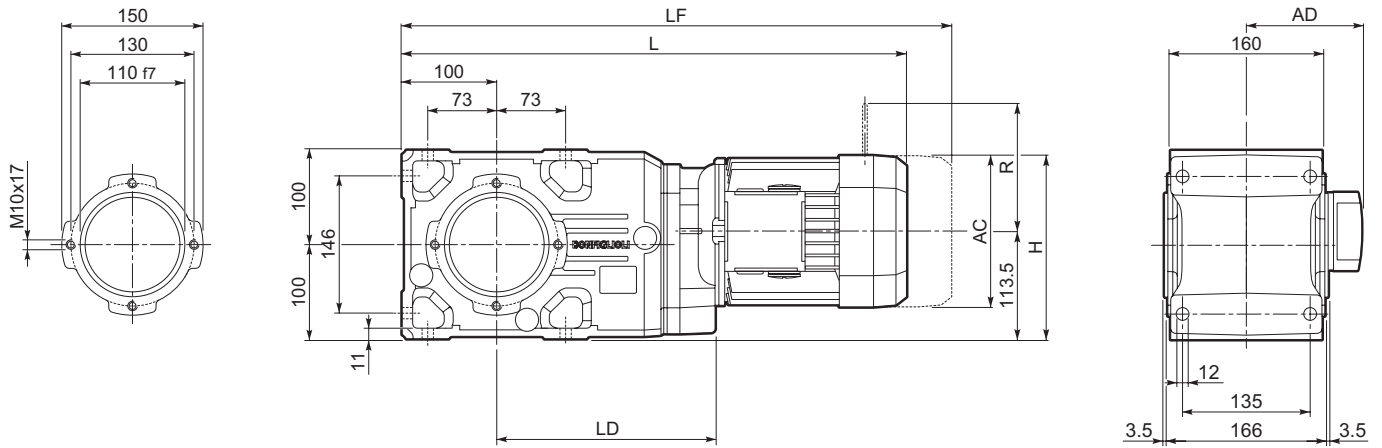

			AC	H	L	LD	AD	Kg	M_FD M_FA		M_FD		M_FA				
									LF	Kg	R	AD	R	AD			
			A 35 2	S1	M1	138	182.5	514.5	217.5	108	34	575.5	36	103	135	124	108
			A 35 2	S2	M2S	156	191.5	543.5	229.5	119	37	613.5	41	129	146	134	119
			A 35 2	S3	M3S	195	211	586.5	239.5	142	42	682.5	50	160	158	160	142
			A 35 2	S3	M3L	195	211	618.5	239.5	142	50	709.5	57	160	158	160	142
			A 35 2	S4	M4S	258	242.5	726.5	—	193	89	835.5	107	226	210	217	193
			A 35 2	S4	M4L	258	242.5	761.5	—	193	97	860.5	115	226	210	217	193
			A 35 3	S05	M05S	121	174	543	—	95	33	609	34	96	122	116	95
			A 35 3	S1	M1	138	182.5	572	—	108	35	633	38	103	135	124	108
			A 35 3	S2	M2S	156	191.5	601	—	119	37	671	41	129	146	134	119
			A 35 3	S3	M3S	195	211	644	—	142	42	740	50	160	158	160	142
			A 35 3	S3	M3L	195	211	676	—	142	50	767	57	160	158	160	142

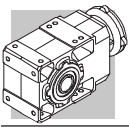

A 35...SK / SC

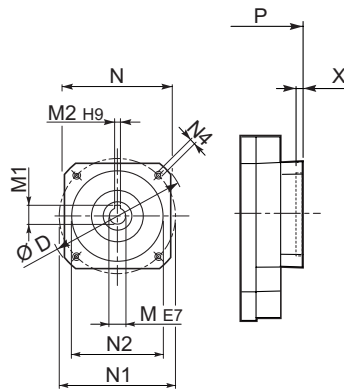
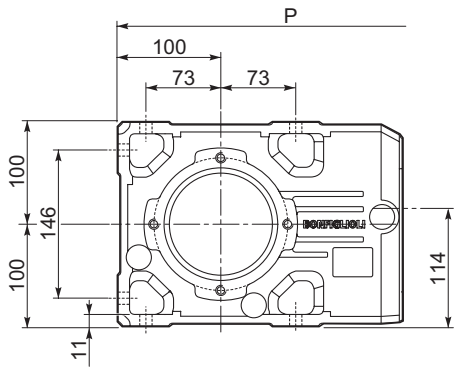

SK...

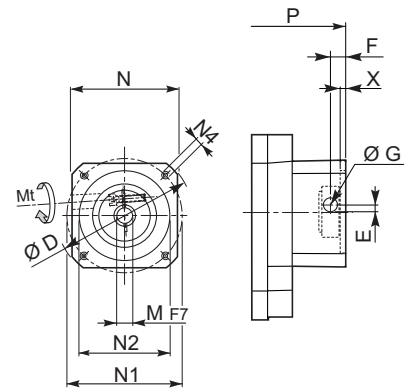

SC...

		D	M	M1	M2	N	N1	N2	N4	X	P		Kg
											2x	3x	
A35 2/3	SK60A	102	11	12.8	4	82	75	60	M5x10	3.5	331	388.5	27/28
A35 2/3	SK60B	102	14	16.3	5	82	75	60	M5x10	4	338	395.5	28/29
A35 2/3	SK80A	115	14	16.3	5	90	100	80	M6x12	4	338	395.5	28/29
A35 2/3	SK80C	120	19	21.8	6	96	100	80	M6x12	4	379	436.5	29/30
A35 2/3	SK95A	130	14	16.3	5	102	115	95	M8x12	4	379	436.5	29/30
A35 2/3	SK95B	130	19	21.8	6	102	115	95	M8x12	4	379	436.5	29/30
A35 2/3	SK95C	130	24	27.3	8	102	115	95	M8x12	4	379	436.5	29/30
A35 2/3	SK110A	150	19	21.8	6	120	130	110	M8x12	5	379	436.5	29/30
A35 2/3	SK110B	150	24	27.3	8	120	130	110	M8x12	5	379	436.5	29/30
A35 2	SK130A	188	24	27.3	8	142	165	130	M10x20	5	379	—	30

		Mt	D	E	F	G	M	N	N1	N2	N4	X	P		Kg
													2x	3x	
A35 2/3	SC60A	M6 15 Nm	102	7	12.5	12.5	11	82	75	60	M5x10	4	358	415.5	28/29
A35 2/3	SC60B	M6 15 Nm	102	7	12.5	12.5	14	82	75	60	M5x10	4	358	415.5	29/30
A35 2/3	SC80A	M6 15 Nm	115	6	12.5	12.5	14	90	100	80	M6x12	4	358	415.5	29/30
A35 2/3	SC80C	M6 15 Nm	120	15.5	14.5	17.75	19	96	100	80	M6x12	4	402.5	460	30/31
A35 2/3	SC95A	M6 15 Nm	130	16.5	15	17.75	14	102	115	95	M8x16	4	402.5	460	30/31
A35 2/3	SC95B	M6 15 Nm	130	16.5	15	17.75	19	102	115	95	M8x16	4	402.5	460	30/31
A35 2/3	SC95C	M6 15 Nm	130	16.5	15	17.75	24	102	115	95	M8x16	4	402.5	460	30/31
A35 2/3	SC110A	M6 15 Nm	150	16.5	16	17.75	19	120	130	110	M8x16	5	402.5	460	32/33
A35 2/3	SC110B	M6 15 Nm	150	16.5	16	17.75	24	120	130	110	M8x16	5	402.5	460	32/33
A35 2	SC130A	M6 15 Nm	188	19	16	17.75	24	142	165	130	M10x20	5	402.5	—	33

A 35...F...

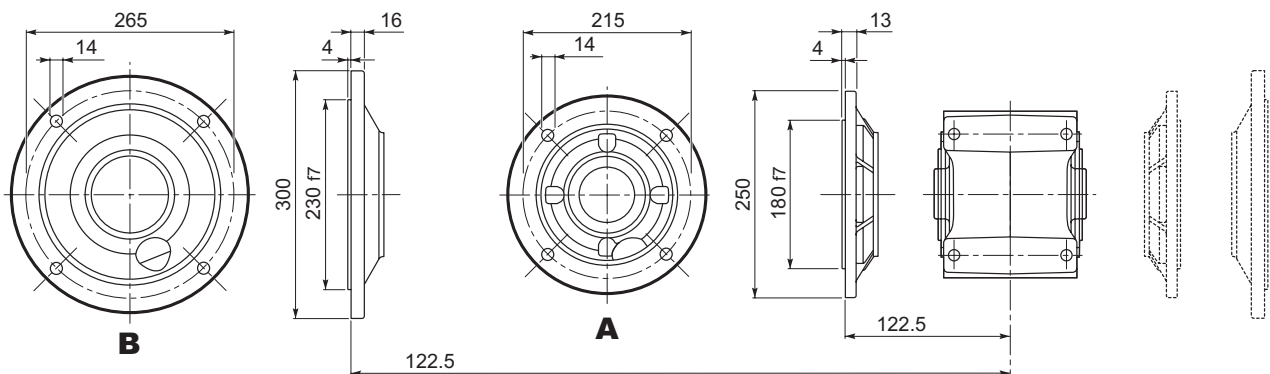

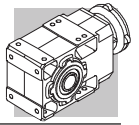

A 35...UR

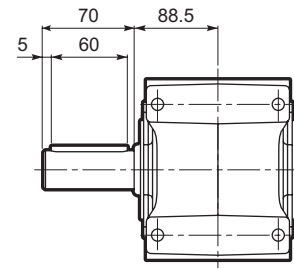
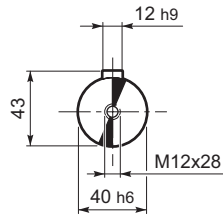

A 35...UD

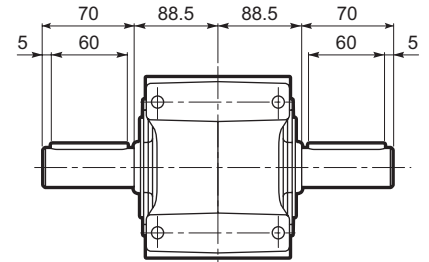
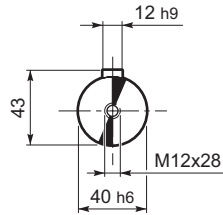

A 35...UH

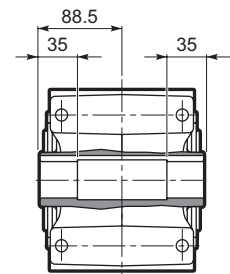
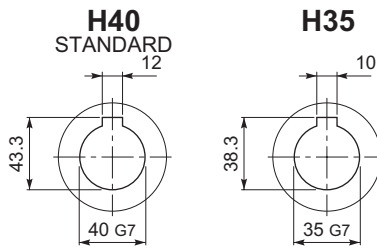

A 35...US

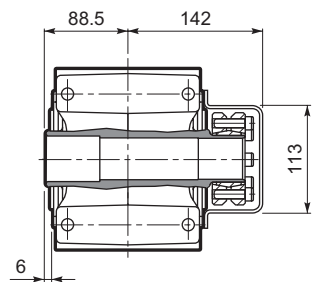
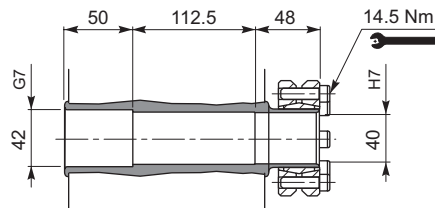

A 35...QF

	Ø
QF35	35
QF40	40

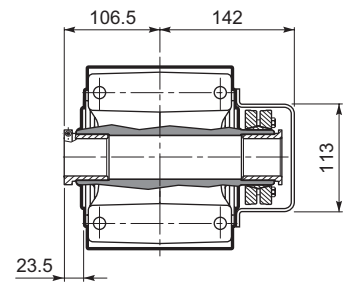
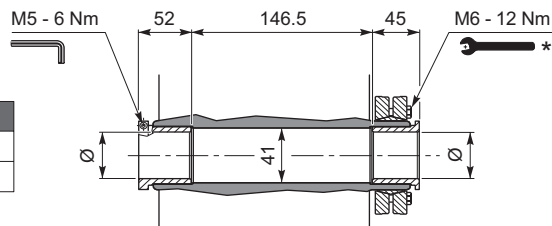

A 35...UV

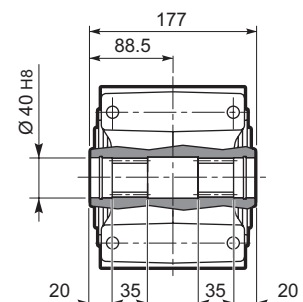

* Attenersi alle ISTRUZIONI PER IL MONTAGGIO fornite con il riduttore.

* Follow the MOUNTING INSTRUCTIONS supplied with the gearbox.

* Befolgen Sie die MONTAGEANLEITUNG die dem Getriebe beiliegt.

* Suivez les INSTRUCTIONS POUR LE MONTAGE fournies avec le réducteur.

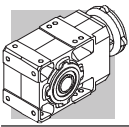

A 41...M

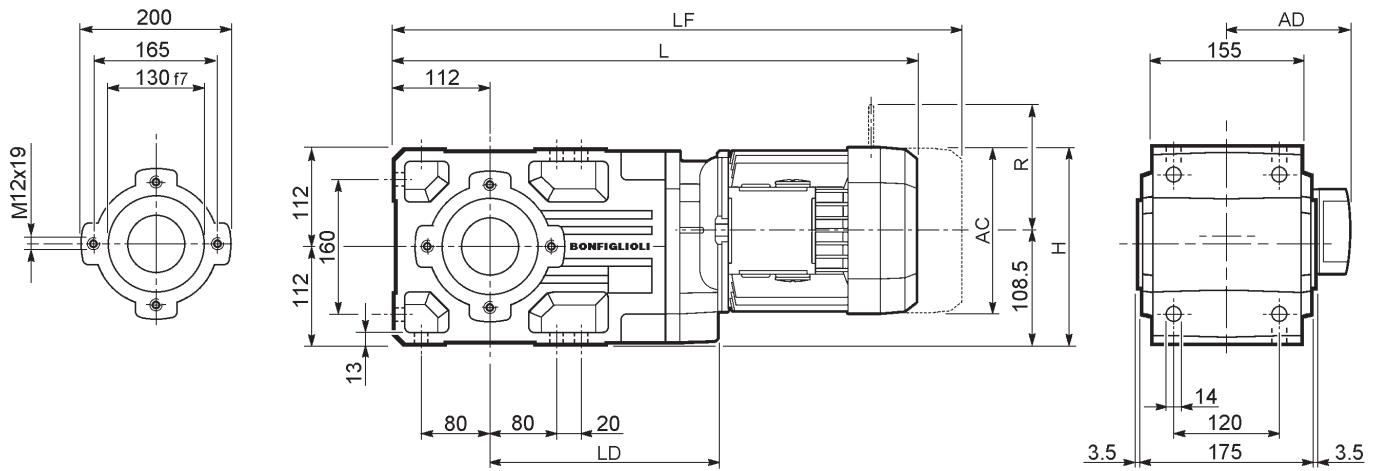

			AC	H	L	LD	AD	Kg	M_FD M_FA		M_FD		M_FA				
									LF	Kg	R	AD	R	AD			
			A 41 2	S1	M1	138	198.5	530	216.5	108	41	591	44	103	135	124	108
			A 41 2	S2	M2S	156	207.5	559	232	119	45	629	49	129	146	134	119
			A 41 2	S3	M3S	195	227	602	248	142	50	698	58	160	158	160	142
			A 41 2	S3	M3L	195	227	634	248	142	58	725	65	160	158	160	142
			A 41 2	S4	M4	258	258.5	742	—	193	92	851	110	226	210	217	193
			A 41 2	S4	M4LC	258	258.5	777	—	193	100	876	118	226	210	217	193
			A 41 3	S05	M05	121	245	562.5	—	95	44	628.5	46	96	122	116	95
			A 41 3	S1	M1	138	198.5	591.5	—	108	46	652.5	49	103	135	124	108
			A 41 3	S2	M2S	156	207.5	620.5	—	119	50	690.5	58	129	146	134	119
			A 41 3	S3	M3S	195	227	663.5	—	142	55	759.5	62	160	158	160	142
			A 41 3	S3	M3L	195	227	695.5	—	142	61	786.5	68	160	158	160	142

A 41...P(IEC)

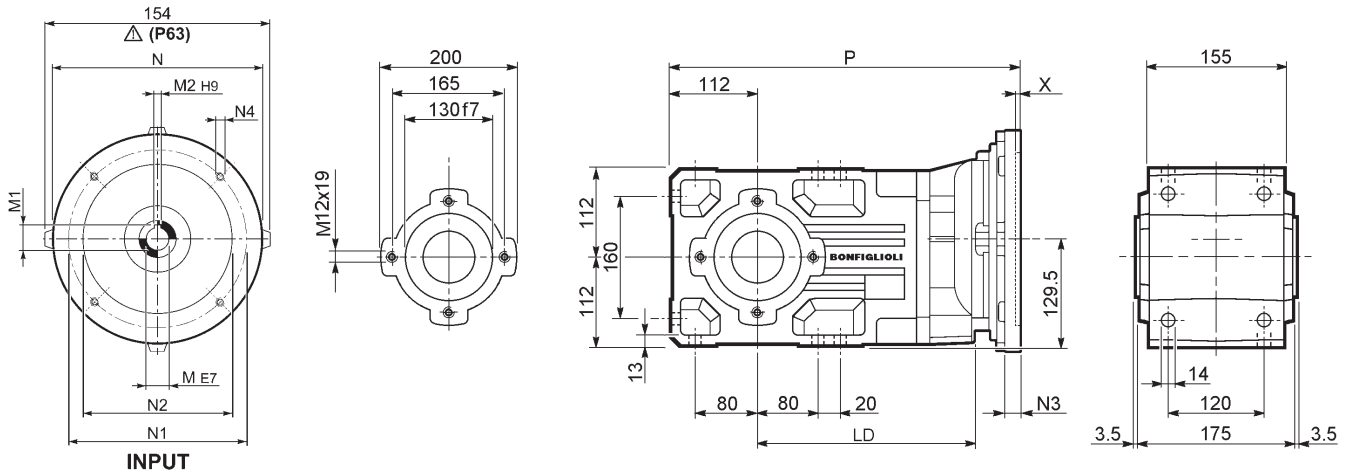
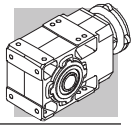

		LD	M	M1	M2	N	N1	N2	N3	N4	X	P	Kg
A 41 2	P63	232	11	12.8	4	140	115	95	—	M8x19	4	375	37
A 41 2	P71	232	14	16.3	5	160	130	110	—	M8x16	4.5	375	38
A 41 2	P80	248	19	21.8	6	200	165	130	—	M10x12	4	394.5	39
A 41 2	P90	248	24	27.3	8	200	165	130	—	M10x12	4	394.5	39
A 41 2	P100	—	28	31.3	8	250	215	180	—	M12x16	4.5	404.5	43
A 41 2	P112	—	28	31.3	8	250	215	180	—	M12x16	4.5	404.5	43
A 41 2	P132	—	38	41.3	10	300	265	230	16	14	5	441	46
A 41 3	P63	—	11	12.8	4	140	115	95	—	M8x19	4	436.5	39
A 41 3	P71	—	14	16.3	5	160	130	110	—	M8x16	4.5	436.5	39
A 41 3	P80	—	19	21.8	6	200	165	130	—	M10x12	4	456	40
A 41 3	P90	—	24	27.3	8	200	165	130	—	M10x12	4	456	40
A 41 3	P100	—	28	31.3	8	250	215	180	—	M12x16	4.5	466	44
A 41 3	P112	—	28	31.3	8	250	215	180	—	M12x16	4.5	466	44

A 41...HS

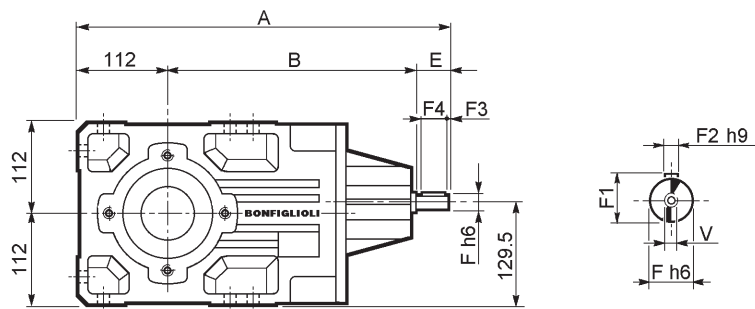

		A	B	E	F	F1	F2	F3	F4	V	Kg
A 41 2	HS	464	302.5	50	24	27	8	2.5	45	M8x19	40.7
A 41 3		486.5	334.5	40	19	21.5	6	2.5	35	M6x16	39.5

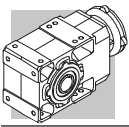

A 41...SK / SC

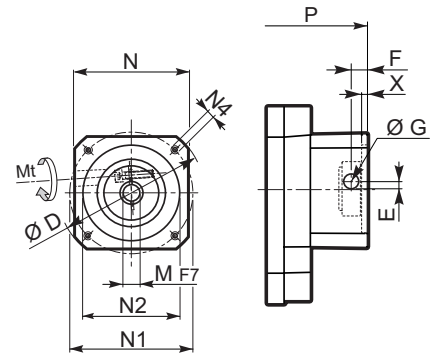
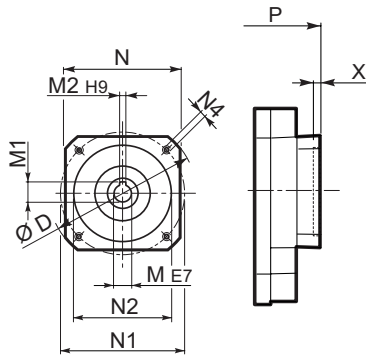
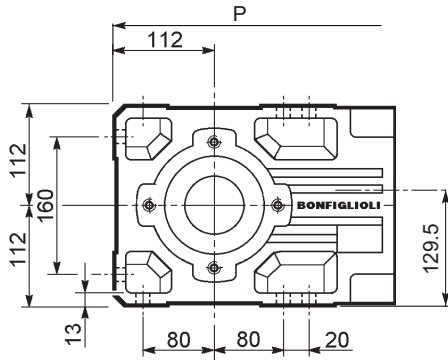

SK...

SC...

		D	M	M1	M2	N	N1	N2	N4	X	P		Kg
											2x	3x	
A41 3	SK60A	102	11	12.8	4	82	75	60	M5x10	3.5	—	408	40
A41 3	SK60B	102	14	16.3	5	82	75	60	M5x10	4	—	415	40
A41 3	SK80A	115	14	16.3	5	90	100	80	M6x12	4	—	415	40
A41 2	SK80B	120	14	16.3	5	96	100	80	M6x12	4	394.5	—	39
A41 2/3	SK80C	120	19	21.8	6	96	100	80	M6x12	4	394.5	456	39/40
A41 2/3	SK95A	130	14	16.3	5	102	115	95	M8x12	4	394.5	456	39/40
A41 2/3	SK95B	130	19	21.8	6	102	115	95	M8x12	4	394.5	456	39/41
A41 2/3	SK95C	130	24	27.3	8	102	115	95	M8x12	4	394.5	456	39/44
A41 2/3	SK110A	150	19	21.8	6	120	130	110	M8x12	5	394.5	456	39/44
A41 2/3	SK110B	150	24	27.3	8	120	130	110	M8x12	5	394.5	456	39/44
A41 2	SK130A	188	24	27.3	8	142	165	130	M10x20	5	394.5	—	41
A41 2	SK130B	189	32	35.3	10	160	165	130	M10x20	5	441	—	43
A41 2	SK180A	240	32	35.3	10	192	215	180	M12x19	5	441	—	43
A41 2	SK180B	240	38	41.3	10	192	215	180	M12x19	5	441	—	43

		Mt	D	E	F	G	M	N	N1	N2	N4	X	P		Kg
													2x	3x	
A41 3	SC60A	M6 15 Nm	102	7	12.5	12.5	11	82	75	60	M5x10	4	—	435	41
A41 3	SC60B	M6 15 Nm	102	7	12.5	12.5	14	82	75	60	M5x10	4	—	435	41
A41 3	SC80A	M6 15 Nm	115	6	12.5	12.5	14	90	100	80	M6x12	4	—	435	41
A41 2	SC80B	M6 15 Nm	120	15.5	14.5	17.75	14	96	100	80	M6x12	4	418	—	40
A41 2/3	SC80C	M6 15 Nm	120	15.5	14.5	17.75	19	96	100	80	M6x12	4	418	479.5	40/41
A41 2/3	SC95A	M6 15 Nm	130	16.5	15	17.75	14	102	115	95	M8x16	4	418	479.5	40/42
A41 2/3	SC95B	M6 15 Nm	130	16.5	15	17.75	19	102	115	95	M8x16	4	418	479.5	40/42
A41 2/3	SC95C	M6 15 Nm	130	16.5	15	17.75	24	102	115	95	M8x16	4	418	479.5	40/43
A41 2/3	SC110A	M6 15 Nm	150	16.5	16	17.75	19	120	130	110	M8x16	5	418	479.5	41/47
A41 2/3	SC110B	M6 15 Nm	150	16.5	16	17.75	24	120	130	110	M8x16	5	418	479.5	41/47
A41 2	SC130A	M6 15 Nm	188	19	16	17.75	24	142	165	130	M10x20	5	418	—	42
A41 2	SC130B	M8 36 Nm	189	20	17	17.75	32	160	165	130	M10x20	5	464	—	46
A41 2	SC180A	M8 36 Nm	240	20	17.5	17.75	32	192	215	180	M12x24	5	468	—	46
A41 2	SC180B	M8 36 Nm	240	20	17.5	17.75	38	192	215	180	M12x24	5	468	—	46

A 41...F...

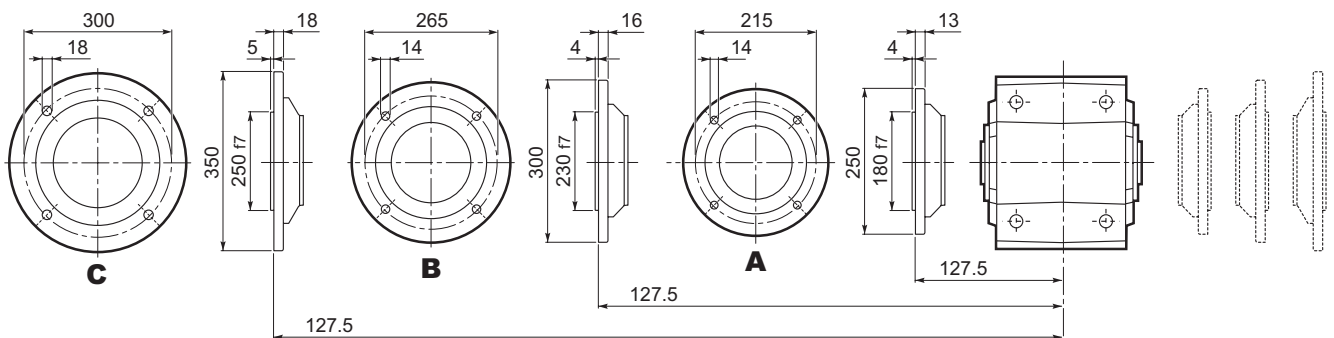

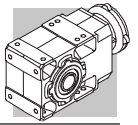

A 41...UR

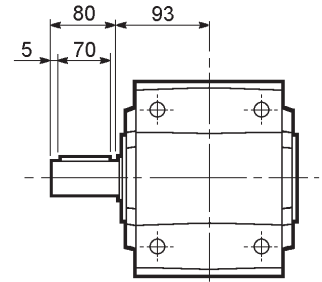
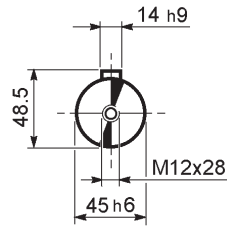

A 41...UD

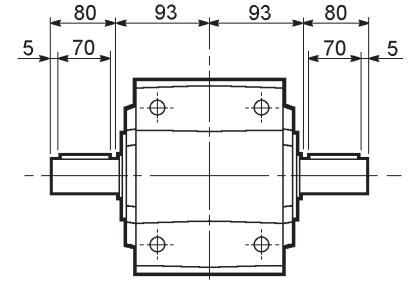
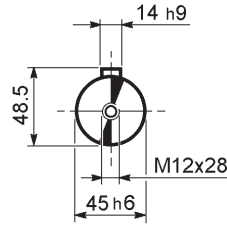

A 41...UH

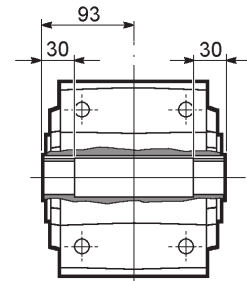
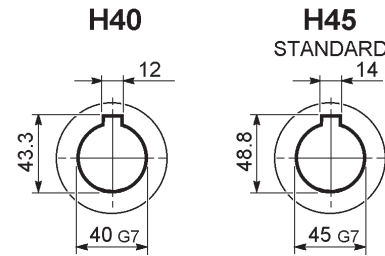

A 41...US

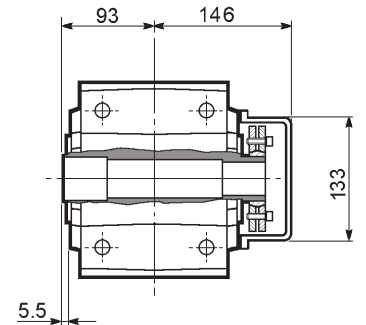
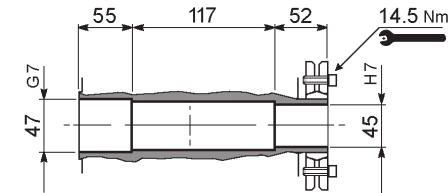

A 41...QF

	Ø
QF40	40
QF45	45

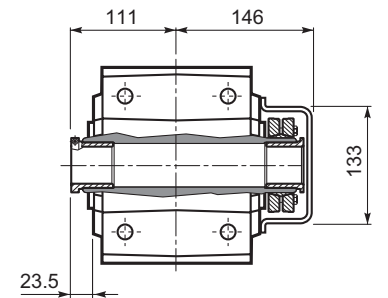
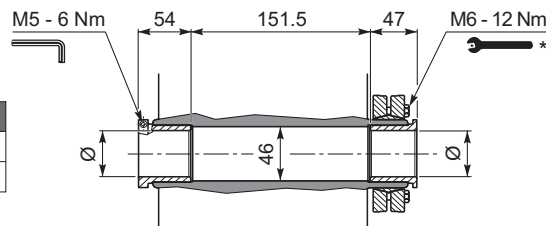

A 41...UV

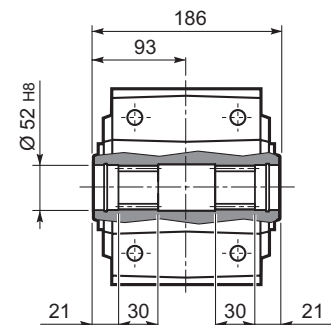

* Attenersi alle ISTRUZIONI PER IL MONTAGGIO fornite con il riduttore.

* Follow the MOUNTING INSTRUCTIONS supplied with the gearbox.

* Befolgen Sie die MONTAGEANLEITUNG die dem Getriebe beiliegt.

* Suivez les INSTRUCTIONS POUR LE MONTAGE fournies avec le réducteur.

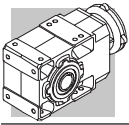

A 50...M

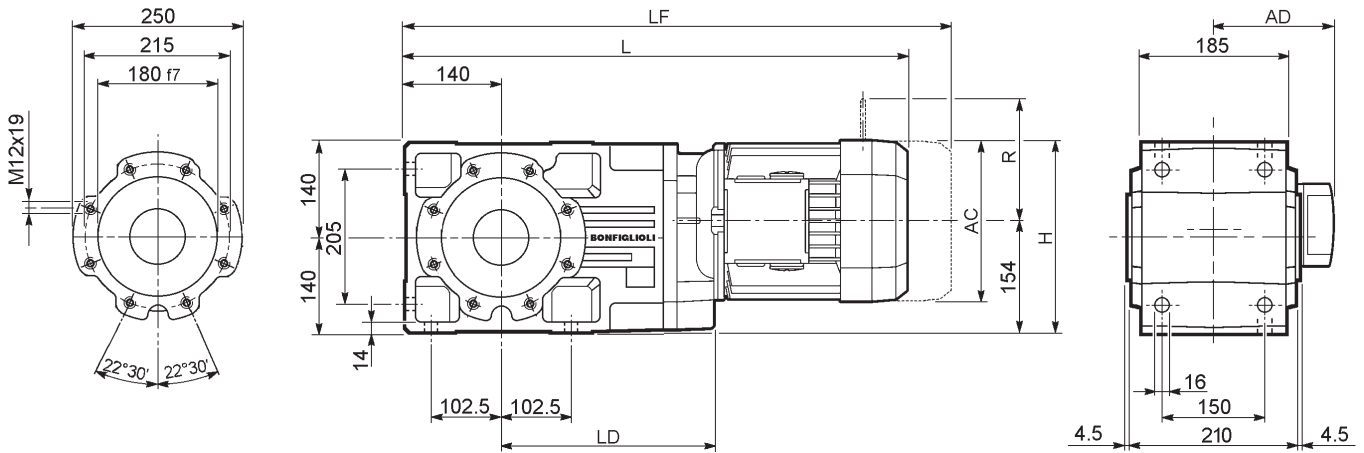

										M_FD M_FA		M_FD		M_FA	
			AC	H	L	LD	AD		LF		R	AD	R	AD	
A 50 2/3	S1	M1	138	223	609.5	—	108	66	670.5	69	103	135	124	108	
A 50 2/3	S2	M2S	156	232	638.5	284.5	119	68	708.5	72	129	146	134	119	
A 50 2/3	S3	M3S	195	251.5	681.5	299.5	142	73	777.5	81	160	158	160	142	
A 50 2/3	S3	M3L	195	251.5	713.5	299.5	142	81	804.5	88	160	158	160	142	
A 50 2/3	S4	M4	258	283	821.5	284.5	193	115	930.5	133	226	210	217	193	
A 50 2/3	S4	M4LC	258	283	856.5	284.5	193	123	955.5	141	226	210	217	193	
A 50 2/3	S5	M5S	310	309	908	—	245	143	1048	173	266	245	247	245	
A 50 2/3	S5	M5L	310	309	952	—	245	159	1092	189	266	245	247	245	
A 50 4	S1	M1	138	223	681	—	108	67	742	70	103	135	124	108	
A 50 4	S2	M2S	156	232	710	—	119	71	780	75	129	146	134	119	
A 50 4	S3	M3S	195	251.5	753	—	142	76	849	76	160	158	160	142	
A 50 4	S3	M3L	195	251.5	785	—	142	83	876	78	160	158	160	142	

A 50...P(IEC)

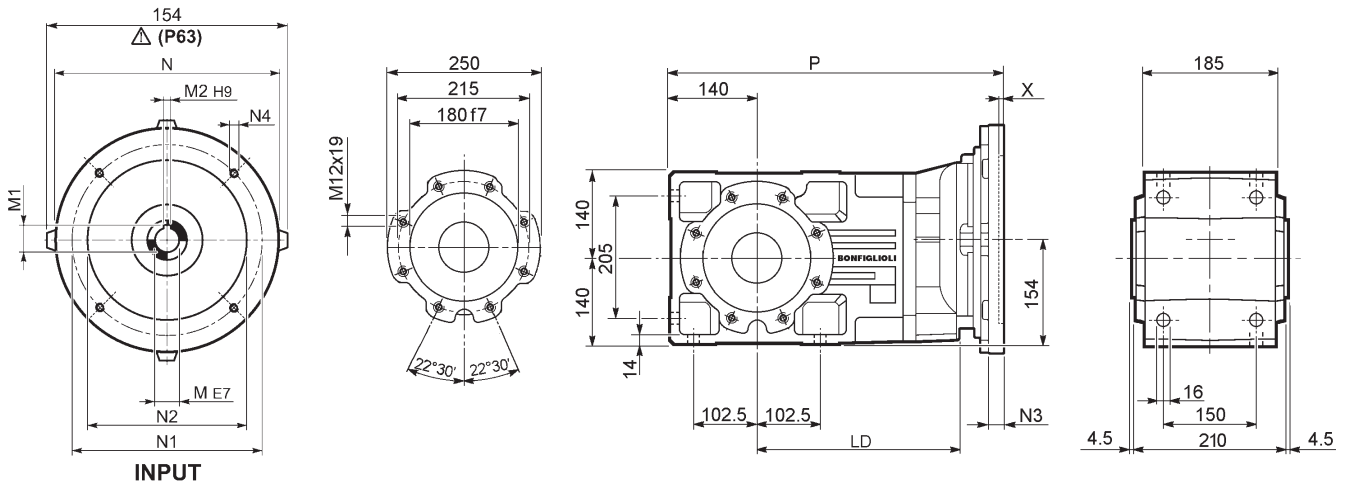
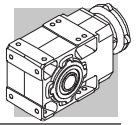

		LD	M	M1	M2	N	N1	N2	N3	N4	X	P	
A 50 2/3	P63	284.5	11	12.8	4	140	115	95	—	M8x19	4	454.5	60
A 50 2/3	P71	284.5	14	16.3	5	160	130	110	—	M8x16	4.5	454.5	60
A 50 2/3	P80	299.5	19	21.8	6	200	165	130	—	M10x12	4	474	61
A 50 2/3	P90	299.5	24	27.3	8	200	165	130	—	M10x12	4	474	61
A 50 2/3	P100	284.5	28	31.3	8	250	215	180	—	M12x16	4.5	484	65
A 50 2/3	P112	284.5	28	31.3	8	250	215	180	—	M12x16	4.5	484	65
A 50 2/3	P132	284.5	38	41.3	10	300	265	230	16	14	5	520.5	68
A 50 2/3	P160	—	42	45.3	12	350	300	250	23	18	5.5	571	72
A 50 2/3	P180	—	48	51.8	14	350	300	250	23	18	5.5	571	72
A 50 4	P63	—	11	12.8	4	140	115	95	—	M8x19	4	526	62
A 50 4	P71	—	14	16.3	5	160	130	110	—	M8x16	4.5	526	62
A 50 4	P80	—	19	21.8	6	200	165	130	—	M10x12	4	545.5	63
A 50 4	P90	—	24	27.3	8	200	165	130	—	M10x12	4	545.5	63
A 50 4	P100	—	28	31.3	8	250	215	180	—	M12x16	4.5	555.5	67
A 50 4	P112	—	28	31.3	8	250	215	180	—	M12x16	4.5	555.5	67

A 50...HS

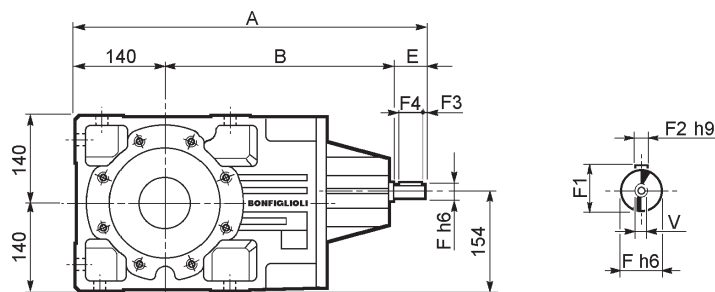

		A	B	E	F	F1	F2	F3	F4	V	
A 50 2	HS	543.5	353.5	50	24	27	8	2.5	45	M8x19	72
A 50 3		543.5	353.5	50	24	27	8	2.5	45	M8x19	76
A 50 4		576	396	40	19	21.5	6	2.5	35	M6x16	77

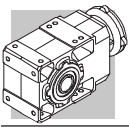

A 50...SK / SC

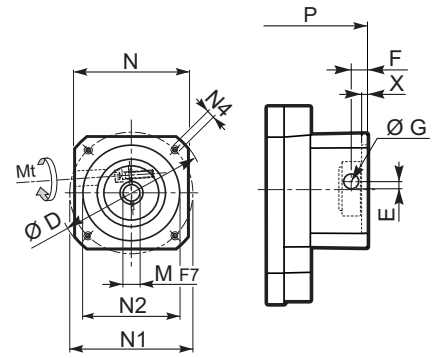
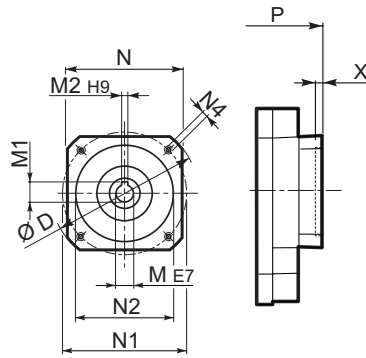
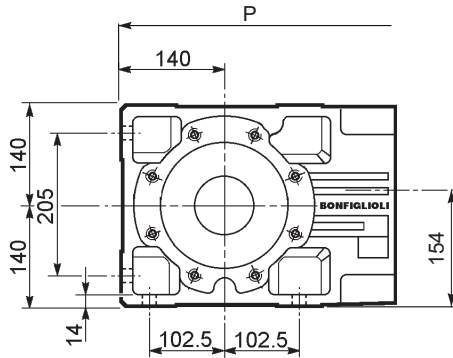

SK...

SC...

		D	M	M1	M2	N	N1	N2	N4	X	P		Kg		
											2/3x	4x			
		A50 4	SK60A	102	11	12.8	4	82	75	60	M5x10	3.5	—	497.5	62
		A50 4	SK60B	102	14	16.3	5	82	75	60	M5x10	4	—	504.5	62
		A50 4	SK80A	115	14	16.3	5	90	100	80	M6x12	4	—	504.5	62
		A50 2/3	SK80B	120	14	16.3	5	96	100	80	M6x12	4	474	—	61/61
		A50 2/3/4	SK80C	120	19	21.8	6	96	100	80	M6x12	4	474	545.5	61/61/63
		A50 2/3/4	SK95A	130	14	16.3	5	102	115	95	M8x12	4	474	545.5	61/61/63
		A50 2/3/4	SK95B	130	19	21.8	6	102	115	95	M8x12	4	474	545.5	61/61/63
		A50 2/3/4	SK95C	130	24	27.3	8	102	115	95	M8x12	4	474	545.5	61/61/63
		A50 2/3/4	SK110A	150	19	21.8	6	120	130	110	M8x12	5	474	545.5	61/61/65
		A50 2/3/4	SK110B	150	24	27.3	8	120	130	110	M8x12	5	474	575	61/61/65
		A50 2/3/4	SK130A	188	24	27.3	8	142	165	130	M10x20	5	474	575	63/63/66
		A50 2/3	SK130B	189	32	35.3	10	160	165	130	M10x20	5	520.5	—	69/69
		A50 2/3	SK180A	240	32	35.3	10	192	215	180	M12x19	5	520.5	—	69/69
		A50 2/3	SK180B	240	38	41.3	10	192	215	180	M12x19	5	520.5	—	69/69

		Mt	D	E	F	G	M	N	N1	N2	N4	X	P		Kg			
													2/3x	4x				
		A50 4	SC60A	M6	15 Nm	102	7	12.5	12.5	11	82	75	60	M5x10	4	—	524.5	63
		A50 4	SC60B	M6	15 Nm	102	7	12.5	12.5	14	82	75	60	M5x10	4	—	524.5	63
		A50 4	SC80A	M6	15 Nm	115	6	12.5	12.5	14	90	100	80	M6x12	4	—	524.5	63
		A50 2/3	SC80B	M6	15 Nm	120	15.5	14.5	17.75	14	96	100	80	M6x12	4	497.5	—	62/62
		A50 2/3/4	SC80C	M6	15 Nm	120	15.5	14.5	17.75	19	96	100	80	M6x12	4	497.5	569	62/62/64
		A50 2/3/4	SC95A	M6	15 Nm	130	16.5	15	17.75	14	102	115	95	M8x16	4	497.5	569	62/62/64
		A50 2/3/4	SC95B	M6	15 Nm	130	16.5	15	17.75	19	102	115	95	M8x16	4	497.5	569	62/62/64
		A50 2/3/4	SC95C	M6	15 Nm	130	16.5	15	17.75	24	102	115	95	M8x16	4	497.5	569	62/62/64
		A50 2/3/4	SC110A	M6	15 Nm	150	16.5	16	17.75	19	120	130	110	M8x16	5	497.5	569	63/63/66
		A50 2/3/4	SC110B	M6	15 Nm	150	16.5	16	17.75	24	120	130	110	M8x16	5	497.5	569	63/63/66
		A50 2/3/4	SC130A	M6	15 Nm	188	19	16	17.75	24	142	165	130	M10x20	5	497.5	569	64/64/67
		A50 2/3	SC130B	M8	36 Nm	189	20	17	17.75	32	160	165	130	M10x20	5	543.5	—	68/68
		A50 2/3	SC180A	M8	36 Nm	240	20	17.5	17.75	32	192	215	180	M12x24	5	547.5	—	68/68
		A50 2/3	SC180B	M8	36 Nm	240	20	17.5	17.75	38	192	215	180	M12x24	5	547.5	—	68/68

A 50...F...

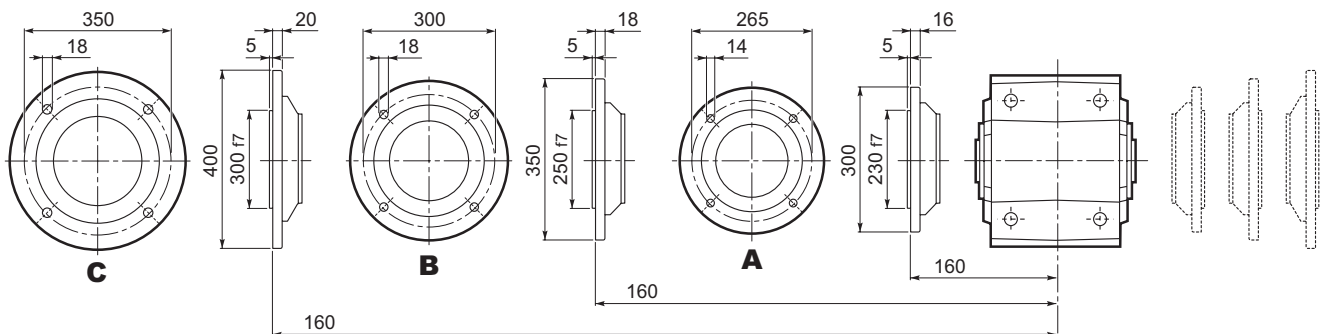

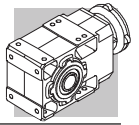

A 50...UR

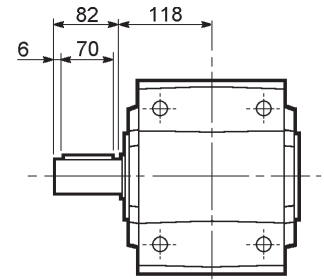
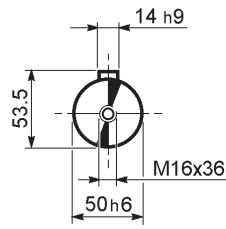

A 50...UD

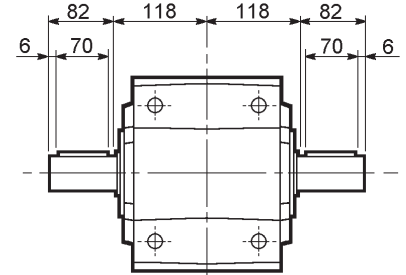
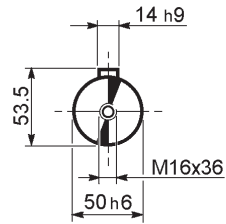

A 50...UH

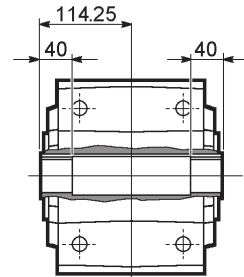
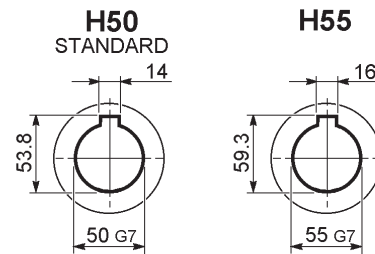

A 50...US

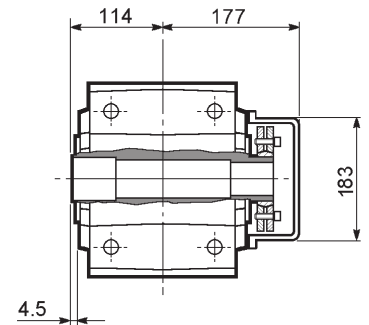
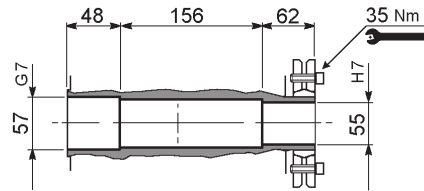

A 50...QF

	Ø
QF50	50
QF55	55

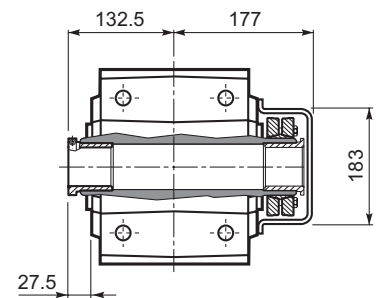
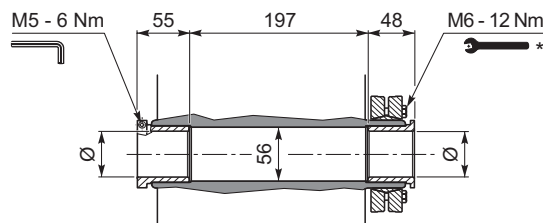

A 50...UV

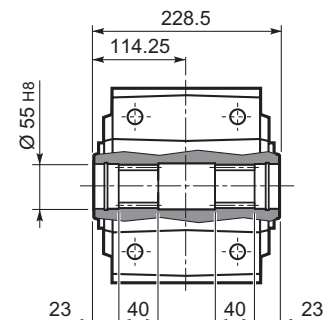

* Attenersi alle ISTRUZIONI PER IL MONTAGGIO fornite con il riduttore.

* Follow the MOUNTING INSTRUCTIONS supplied with the gearbox.

* Befolgen Sie die MONTAGEANLEITUNG die dem Getriebe beiliegt.

* Suivez les INSTRUCTIONS POUR LE MONTAGE fournies avec le réducteur.

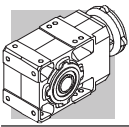

A 55...M

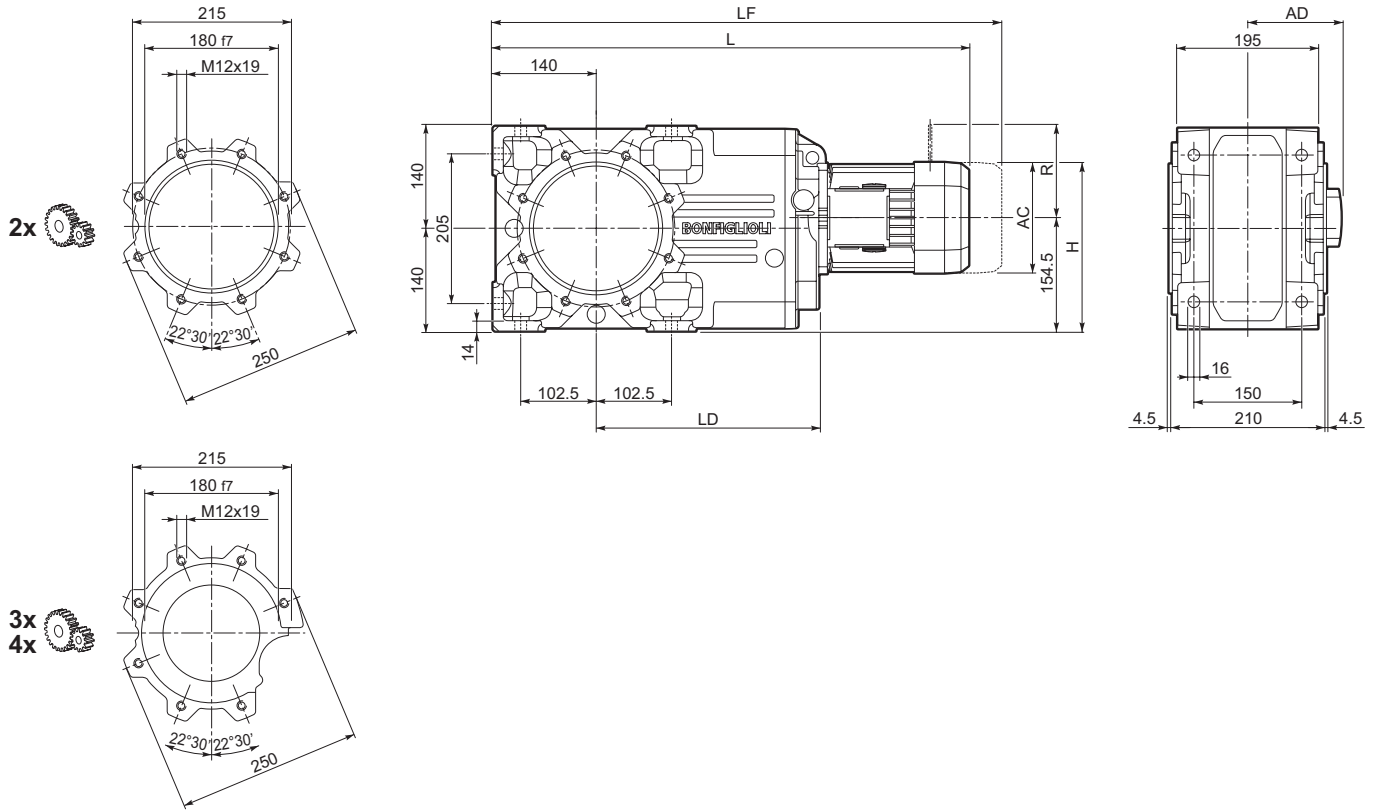
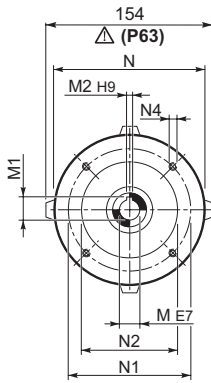
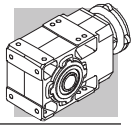
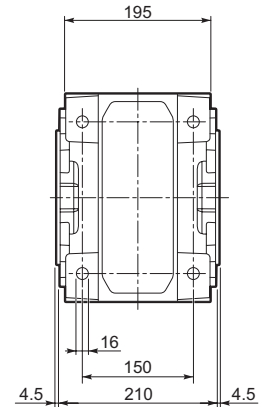
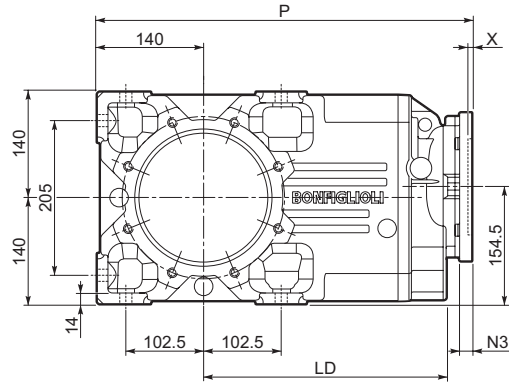

Image	S	M	AC	H	L	LD	AD	Kg	M_FD M_FA		M_FD		M_FA		
									LF	Kg	R	AD	R	AD	
	A 55 3	S1	M1	138	198.5	627.5	—	108	81	688.5	84	103	135	124	108
	A 55 2/3	S2	M2S	156	232	656.5	302.5	119	88	726.5	92	129	146	134	119
	A 55 2/3	S3	M3S	195	251	699.5	317.5	142	93	795.5	99	160	158	160	142
	A 55 2/3	S3	M3L	195	251	731.5	317.5	142	101	822.5	108	160	158	160	142
	A 55 2/3	S4	M4	258	283	839.5	302.5	193	135	948.5	153	226	210	217	193
	A 55 2/3	S4	M4LC	258	283	874.5	302.5	193	143	973.5	161	226	210	217	193
	A 55 2/3	S5	M5S	310	309.5	926	—	245	163	1066	193	266	245	247	245
	A 55 2/3	S5	M5L	310	309.5	970	—	245	179	1110	209	266	245	247	245
	A 55 4	S1	M1	138	223	699	—	108	82	760	85	103	135	124	108
	A 55 4	S2	M2S	156	232	728	—	119	86	798	90	129	146	134	119
	A 55 4	S3	M3S	195	251.5	771	—	142	91	867	98	160	158	160	142
	A 55 4	S3	M3L	195	251.5	803	—	142	98	894	105	160	158	160	142

A 55...P(IEC)



INPUT



		LD	M	M1	M2	N	N1	N2	N3	N4	X	P	Kg
		302.5	11	12.8	4	140	115	95	—	M8x19	4	472.5	75
		302.5	14	16.3	5	160	130	110	—	M8x16	4.5	472.5	75
		317.5	19	21.8	6	200	165	130	—	M10x12	4	492	81
		317.5	24	27.3	8	200	165	130	—	M10x12	4	492	81
		302.5	28	31.3	8	250	215	180	—	M12x16	4.5	502	85
		302.5	28	31.3	8	250	215	180	—	M12x16	4.5	502	85
		302.5	38	41.3	10	300	265	230	16	14	5	538.5	93
		—	42	45.3	12	350	300	250	23	18	5.5	589	110
		—	48	51.8	14	350	300	250	23	18	5.5	589	110
		—	11	12.8	4	140	115	95	—	M8x19	4	544	77
		—	14	16.3	5	160	130	110	—	M8x16	4.5	544	77
		—	19	21.8	6	200	165	130	—	M10x12	4	563.5	78
		—	24	27.3	8	200	165	130	—	M10x12	4	563.5	78
		—	28	31.3	8	250	215	180	—	M12x16	4.5	573.5	82
		—	28	31.3	8	250	215	180	—	M12x16	4.5	573.5	82

A 55...HS

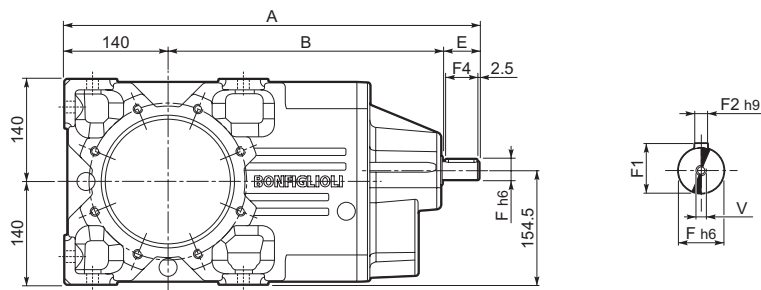

		A	B	E	F	F1	F2	F3	F4	V	Kg
		561.5	371.5	50	24	27	8	2.5	45	M8x19	96
		561.5	371.5	50	24	27	8	2.5	45	M8x19	91
		594	414	40	19	21.5	6	2.5	35	M6x16	92

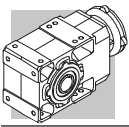

A 55...SK / SC

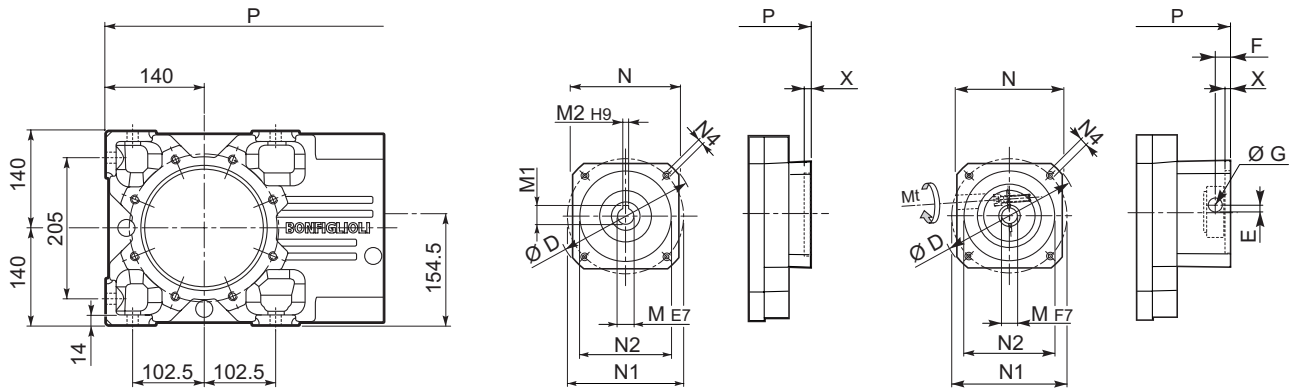

SK...

SC...

		D	M	M1	M2	N	N1	N2	N4	X	P		Kg
											2/3x	4x	
A55 4	SK60A	102	11	12.8	4	82	75	60	M5x10	3.5	—	515.5	76
A55 4	SK60B	102	14	16.3	5	82	75	60	M5x10	4	—	522.5	76
A55 4	SK80A	115	14	16.3	5	90	100	80	M6x12	4	—	522.5	76
A55 3	SK80B	120	14	16.3	5	96	100	80	M6x12	4	492	—	81
A55 2/3/4	SK80C	120	19	21.8	6	96	100	80	M6x12	4	492	563.5	81/81/77
A55 3/4	SK95A	130	14	16.3	5	102	115	95	M8x12	4	492	563.5	81/81/77
A55 2/3/4	SK95B	130	19	21.8	6	102	115	95	M8x12	4	492	563.5	81/81/77
A55 2/3/4	SK95C	130	24	27.3	8	102	115	95	M8x12	4	492	563.5	81/81/77
A55 2/3/4	SK110A	150	19	21.8	6	120	130	110	M8x12	5	492	593	81/81/78
A55 2/3/4	SK110B	150	24	27.3	8	120	130	110	M8x12	5	492	593	81/81/78
A55 2/3/4	SK130A	188	24	27.3	8	142	165	130	M10x20	5	492	593	83/83/79
A55 2/3	SK130B	189	32	35.3	10	160	165	130	M10x20	5	538.5	—	90/90
A55 2/3	SK180A	240	32	35.3	10	192	215	180	M12x19	5	538.5	—	90/90
A55 2/3	SK180B	240	38	41.3	10	192	215	180	M12x19	5	538.5	—	90/90

		Mt	D	E	F	G	M	N	N1	N2	N4	X	P		Kg
													2/3x	4x	
A55 4	SC60A	M6 15 Nm	102	7	12.5	12.5	11	82	75	60	M5x10	4	—	542.5	77
A55 4	SC60B	M6 15 Nm	102	7	12.5	12.5	14	82	75	60	M5x10	4	—	542.5	77
A55 4	SC80A	M6 15 Nm	115	6	12.5	12.5	14	90	100	80	M6x12	4	—	542.5	77
A55 3	SC80B	M6 15 Nm	120	15.5	14.5	17.75	14	96	100	80	M6x12	4	515.5	—	82
A55 2/3/4	SC80C	M6 15 Nm	120	15.5	14.5	17.75	19	96	100	80	M6x12	4	515.5	587	82/82/78
A55 3/4	SC95A	M6 15 Nm	130	16.5	15	17.75	14	102	115	95	M8x16	4	515.5	587	82/82/78
A55 2/3/4	SC95B	M6 15 Nm	130	16.5	15	17.75	19	102	115	95	M8x16	4	515.5	587	82/82/78
A55 2/3/4	SC95C	M6 15 Nm	130	16.5	15	17.75	24	102	115	95	M8x16	4	515.5	587	82/82/78
A55 2/3/4	SC110A	M6 15 Nm	150	16.5	16	17.75	19	120	130	110	M8x16	5	515.5	587	83/83/79
A55 2/3/4	SC110B	M6 15 Nm	150	16.5	16	17.75	24	120	130	110	M8x16	5	515.5	587	83/83/79
A55 2/3/4	SC130A	M6 15 Nm	188	19	16	17.75	24	142	165	130	M10x20	5	515.5	587	84/84/80
A55 2/3	SC130B	M8 36 Nm	189	20	17	17.75	32	160	165	130	M10x20	5	561.5	—	93/93
A55 2/3	SC180A	M8 36 Nm	240	20	17.5	17.75	32	192	215	180	M12x24	5	565.5	—	93/93
A55 2/3	SC180B	M8 36 Nm	240	20	17.5	17.75	38	192	215	180	M12x24	5	565.5	—	93/93

A 55...F...

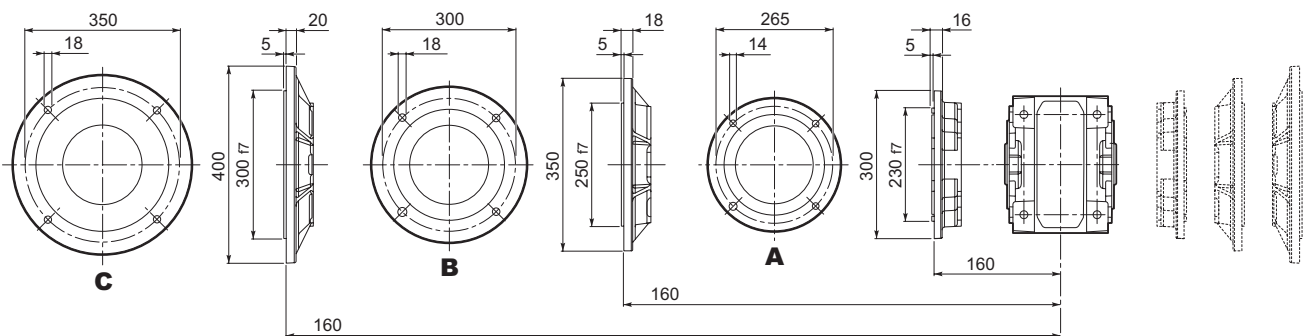

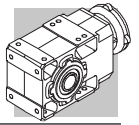

A 55...UR

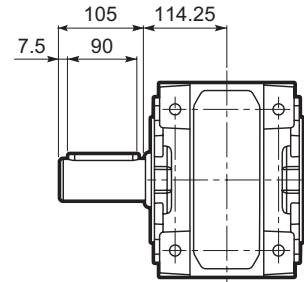
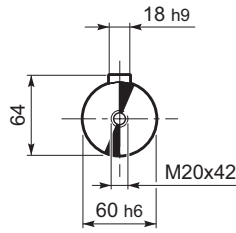

A 55...UD

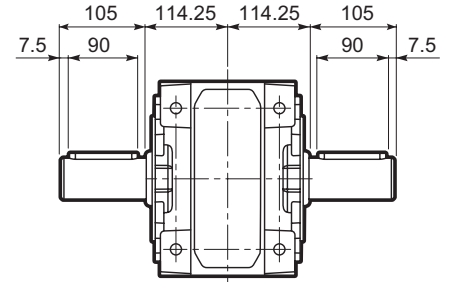
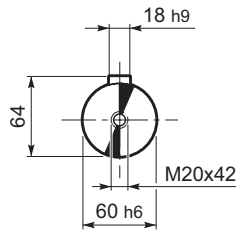

A 55...UH

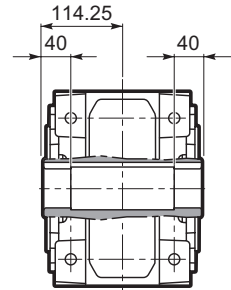
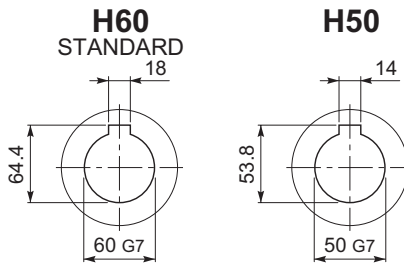

A 55...US

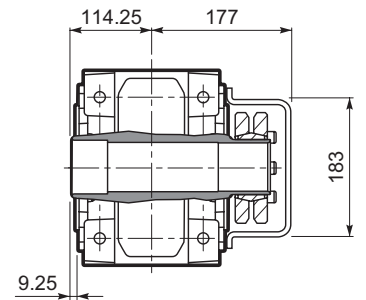
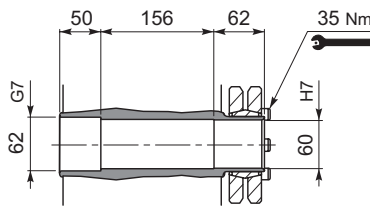

A 55...QF

	Ø
QF55	55
QF60	60

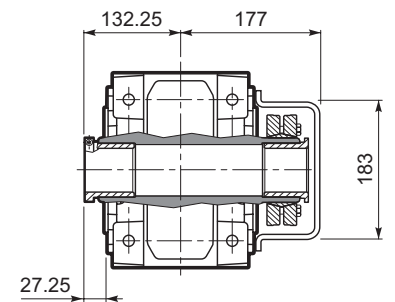
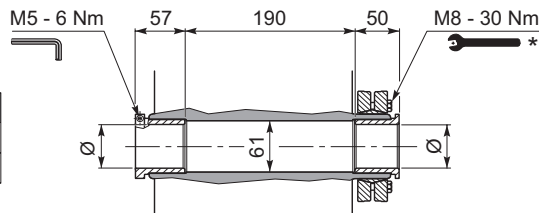

A 55...UV

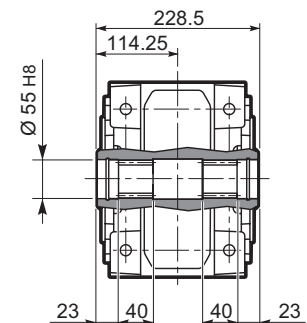

* Attenersi alle ISTRUZIONI PER IL MONTAGGIO fornite con il riduttore.

* Follow the MOUNTING INSTRUCTIONS supplied with the gearbox.



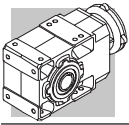

* Befolgen Sie die MONTAGEANLEITUNG die dem Getriebe beiliegt.

* Suivez les INSTRUCTIONS POUR LE MONTAGE fournies avec le réducteur.

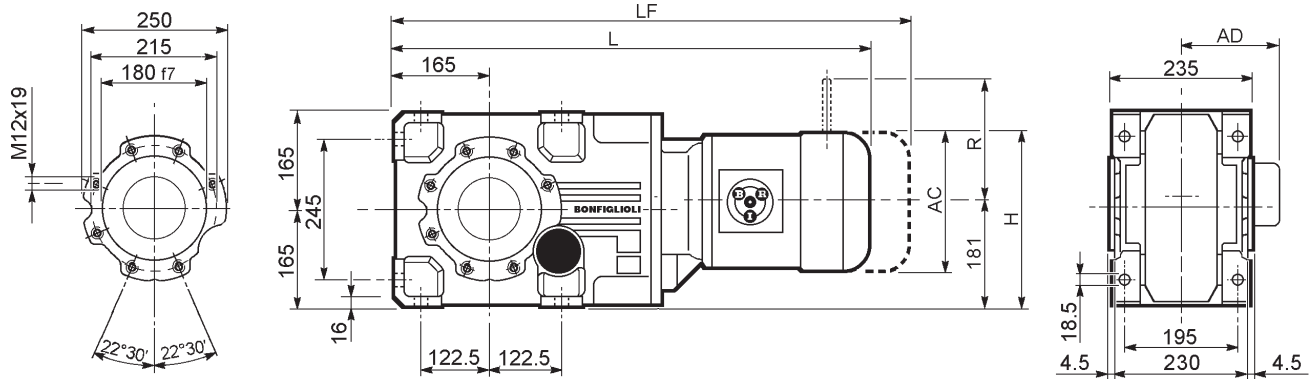

A 60...M



  								M_FD M_FA		M_FD		M_FA	
	AC	H	L	AD	 Kg	LF	 Kg	R	AD	R	AD		
A 60 2/3 S2 M2S	156	256.5	700.5	119	98	770.5	102	129	146	134	119		
A 60 2/3 S3 M3S	195	276	743.5	142	103	839.5	111	160	158	160	142		
A 60 2/3 S3 M3L	195	276	775.5	142	111	866.5	118	160	158	160	142		
A 60 2/3 S4 M4	258	307.5	883.5	193	145	992.5	163	226	210	217	193		
A 60 2/3 S4 M4LC	258	307.5	918.5	193	153	1017.5	171	226	210	217	193		
A 60 2/3 S5 M5S	310	333.5	970	245	173	1110	203	266	245	247	245		
A 60 2/3 S5 M5L	310	333.5	1014	245	189	1154	219	266	245	247	245		
A 60 4 S1 M1	138	247.5	742	108	100	803	103	103	135	124	108		
A 60 4 S2 M2S	156	256.5	771	119	104	841	108	129	146	134	119		
A 60 4 S3 M3S	195	276	814	142	109	910	117	160	158	160	142		
A 60 4 S3 M3L	195	276	846	142	117	937	124	160	158	160	142		

A 60...P(IEC)

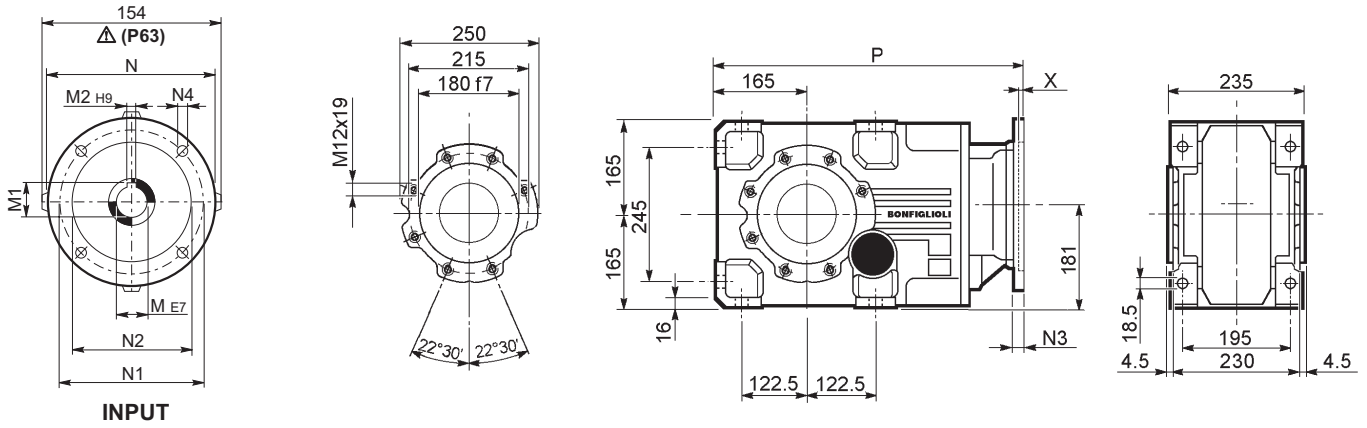
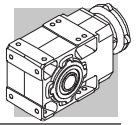

INPUT

		M	M1	M2	N	N1	N2	N3	N4	X	P	kg
		11	12.8	4	140	115	95	—	M8x19	4	516.5	90
		14	16.3	5	160	130	110	—	M8x16	4.5	516.5	90
		19	21.8	6	200	165	130	—	M10x12	4	536	91
		24	27.3	8	200	165	130	—	M10x12	4	536	91
		28	31.3	8	250	215	180	—	M12x16	4.5	546	95
		28	31.3	8	250	215	180	—	M12x16	4.5	546	95
		38	41.3	10	300	265	230	16	14	5	582.5	104
		42	45.3	12	350	300	250	23	18	5.5	633	121
		48	51.8	14	350	300	250	23	18	5.5	633	121
		11	12.8	4	140	115	95	—	M8x19	4	587	88
		14	16.3	5	160	130	110	—	M8x16	4.5	587	88
		19	21.8	6	200	165	130	—	M10x12	4	606.5	90
		24	27.3	8	200	165	130	—	M10x12	4	606.5	90
		28	31.3	8	250	215	180	—	M12x16	4.5	616.5	94
		28	31.3	8	250	215	180	—	M12x16	4.5	616.5	94

A 60...HS

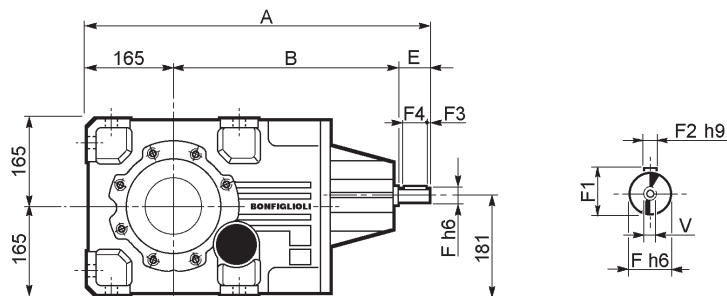

		A	B	E	F	F1	F2	F3	F4	V	kg
		633	408	60	28	31	8	5.0	50	M10x22	106
		633	408	60	28	31	8	5.0	50	M10x22	106
		676	461	50	24	27	8	2.5	45	M8x19	112

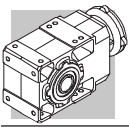

A 60...SK / SC

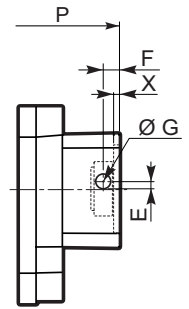
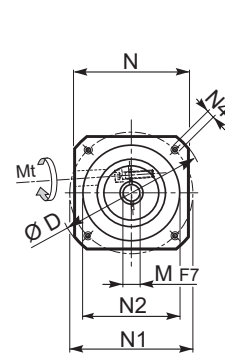
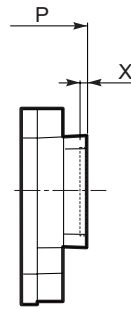
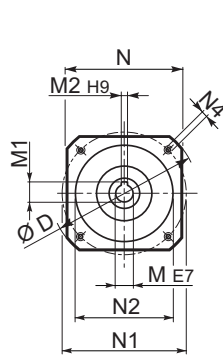
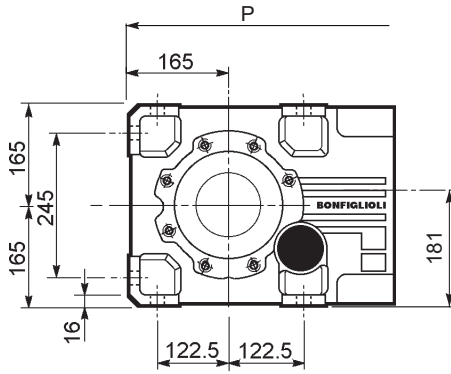

SK...

SC...

Image	Image	D	M	M1	M2	N	N1	N2	N4	X	P		Kg		
											2/3x	4x			
		A60 4	SK80B	120	14	16.3	5	96	100	80	M6x12	4	—	606.5	89
		A60 2/3/4	SK80C	120	19	21.8	6	96	100	80	M6x12	4	536	606.5	93/93/92
		A60 2/3/4	SK95A	130	14	16.3	5	102	115	95	M8x12	4	536	606.5	93/93/92
		A60 2/3/4	SK95B	130	19	21.8	6	102	115	95	M8x12	4	536	606.5	93/93/92
		A60 2/3/4	SK95C	130	24	27.3	8	102	115	95	M8x12	4	536	606.5	93/93/92
		A60 2/3/4	SK110A	140	19	21.8	6	120	130	110	M8x12	5	536	606.5	93/93/92
		A60 2/3/4	SK110B	140	24	27.3	8	120	130	110	M8x12	5	536	606.5	93/93/92
		A60 2/3/4	SK130A	188	24	27.3	8	142	165	130	M10x20	5	536	606.5	97/97/103
		A60 2/3	SK130B	189	32	35.3	10	160	165	130	M10x20	5	582.5	—	102/102
		A60 2/3	SK180A	240	32	35.3	10	192	215	180	M12x19	5	582.5	—	102/102
		A60 2/3	SK180B	240	38	41.3	10	192	215	180	M12x19	5	582.5	—	102/102

Image	Image	Image	Mt	D	E	F	G	M	N	N1	N2	N4	X	P		Kg		
														2/3x	4x			
			M6 15 Nm	A60 4	SC80B	120	15.5	14.5	17.75	14	96	100	80	M6x12	4	—	630	90
			M6 15 Nm	A60 2/3/4	SC80C	120	15.5	14.5	17.75	19	96	100	80	M6x12	4	559.5	630	94/94/93
			M6 15 Nm	A60 2/3/4	SC95A	130	16.5	15	17.75	14	102	115	95	M8x16	4	559.5	630	94/94/93
			M6 15 Nm	A60 2/3/4	SC95B	130	16.5	15	17.75	19	102	115	95	M8x16	4	559.5	630	94/94/93
			M6 15 Nm	A60 2/3/4	SC95C	130	16.5	15	17.75	24	102	115	95	M8x16	4	559.5	630	94/94/93
			M6 15 Nm	A60 2/3/4	SC110A	140	16.5	16	17.75	19	120	130	110	M8x16	5	559.5	630	95/95/93
			M6 15 Nm	A60 2/3/4	SC110B	140	16.5	16	17.75	24	120	130	110	M8x16	5	559.5	630	95/95/93
			M6 15 Nm	A60 2/3/4	SC130A	188	19	16	17.75	24	142	165	130	M10x20	5	559.5	630	96/96/104
			M8 36 Nm	A60 2/3	SC130B	189	20	17	17.75	32	160	165	130	M10x20	5	605.5	—	105/105
			M8 36 Nm	A60 2/3	SC180A	240	20	17.5	17.75	32	192	215	180	M12x24	5	609.5	—	105/105
			M8 36 Nm	A60 2/3	SC180B	240	20	17.5	17.75	38	192	215	180	M12x24	5	609.5	—	105/105

A 60...F...

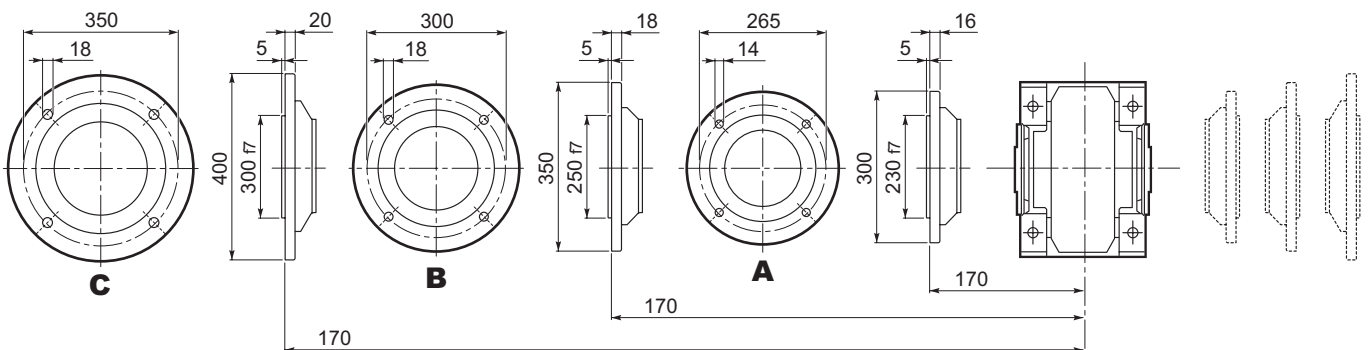

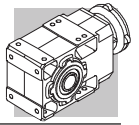

A 60...UR

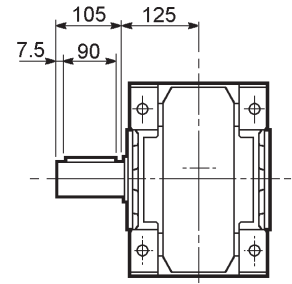
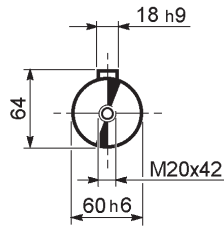

A 60...UD

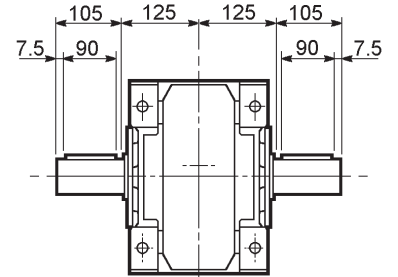
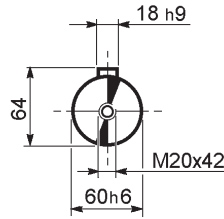

A 60...UH

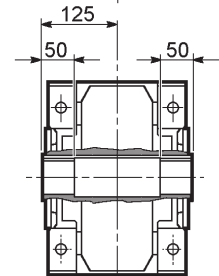
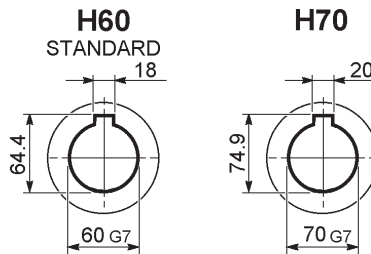

A 60...US

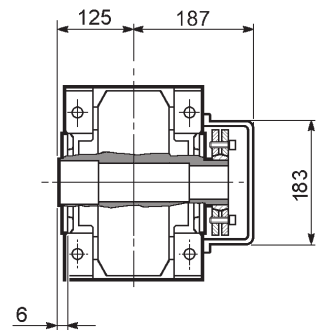
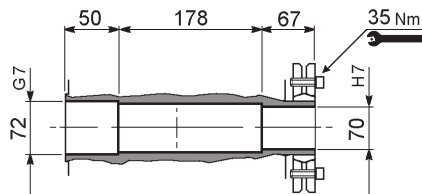

A 60...QF

	Ø
QF60	60
QF65	65
QF70	70

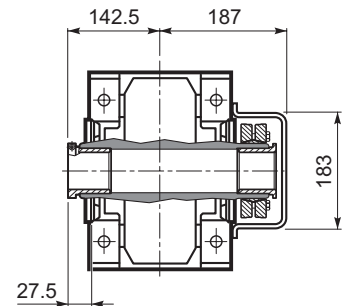
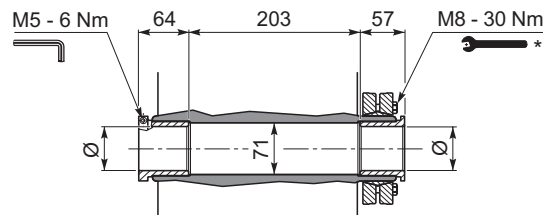

A 60...UV

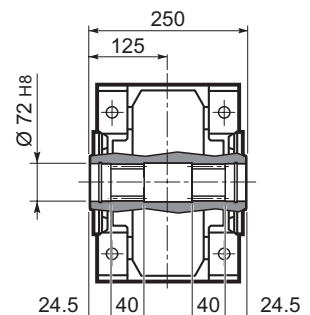

* Attenersi alle ISTRUZIONI PER IL MONTAGGIO fornite con il riduttore.

* Follow the MOUNTING INSTRUCTIONS supplied with the gearbox.

* Befolgen Sie die MONTAGEANLEITUNG die dem Getriebe beiliegt.

* Suivez les INSTRUCTIONS POUR LE MONTAGE fournies avec le réducteur.

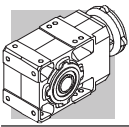

A 70...M

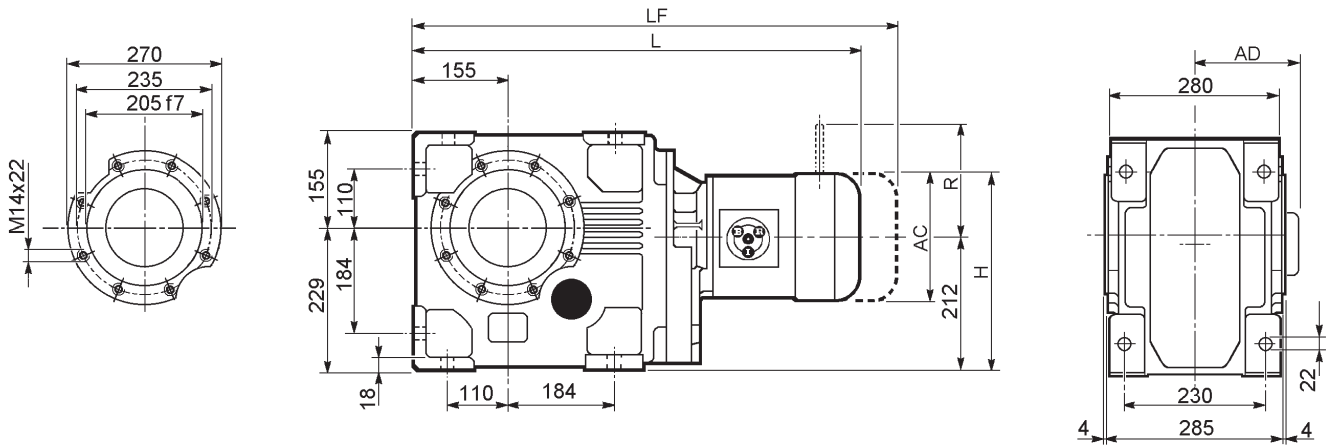

									M_FD M_FA		M_FD		M_FA			
			AC	H	L	AD		LF		R	AD	R	AD			
			A 70 3	S2	M2S	156	290	688.5	119	152	758.5	156	129	146	134	119
			A 70 3	S3	M3S	195	309.5	731.5	142	157	827.5	164	160	158	160	142
			A 70 3	S3	M3L	195	309.5	763.5	142	164	854.5	171	160	158	160	142
			A 70 3	S4	M4	258	341	872.5	193	198	981.5	216	226	210	217	193
			A 70 3	S4	M4LC	258	341	907.5	193	206	1006.5	224	226	210	217	193
			A 70 3	S5	M5S	310	367	958	245	226	1098	256	266	245	247	245
			A 70 3	S5	M5L	310	367	1002	245	242	1142	272	266	245	247	245
			A 70 4	S1	M1	138	281	710.5	108	152	771.5	155	103	135	124	108
			A 70 4	S2	M2S	156	290	739.5	119	156	809.5	160	129	146	134	119
			A 70 4	S3	M3S	195	309.5	782.5	142	161	878.5	168	160	158	160	142
			A 70 4	S3	M3L	195	309.5	814.5	142	168	905.5	175	160	158	160	142
			A 70 4	S4	M4	258	341	922.5	193	202	1031.5	220	226	210	217	193
			A 70 4	S4	M4LC	258	341	957.5	193	210	1056.5	228	226	210	217	193

A 70...P(IEC)

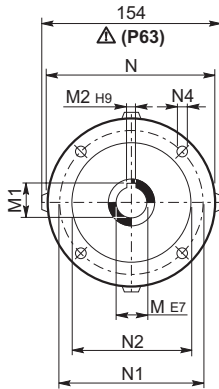
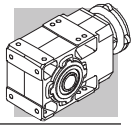

INPUT

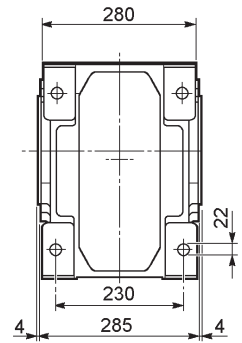
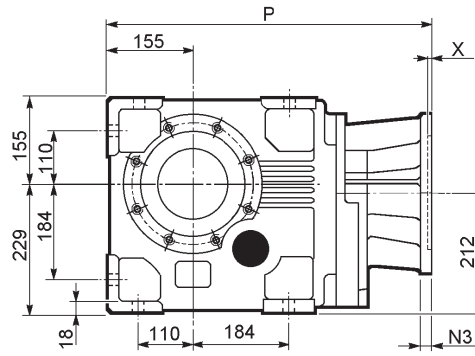
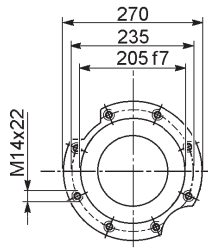

		M	M1	M2	N	N1	N2	N3	N4	X	P	
		19	21.8	6	200	165	130	—	M10x12	4	524	144
		24	27.3	8	200	165	130	—	M10x12	4	524	144
		28	31.3	8	250	215	180	—	M12x16	4.5	534	146
		28	31.3	8	250	215	180	—	M12x16	4.5	534	146
		38	41.3	10	300	265	230	16	14	5	570.5	154
		42	45.3	12	350	300	250	23	18	6	626	169
		48	51.8	14	350	300	250	23	18	6	626	169
		55	59.3	16	400	350	300	—	M16x25	7	651	179
		11	12.8	4	140	115	95	—	M8x19	4	555.5	146
		14	16.3	5	160	130	110	—	M8x16	4.5	555.5	146
		19	21.8	6	200	165	130	—	M10x12	4	575	147
		24	27.3	8	200	165	130	—	M10x12	4	575	147
		28	31.3	8	250	215	180	—	M12x16	4.5	585	148
		28	31.3	8	250	215	180	—	M12x16	4.5	585	148
		38	41.3	10	300	265	230	16	14	5	618.5	157

A 70...HS

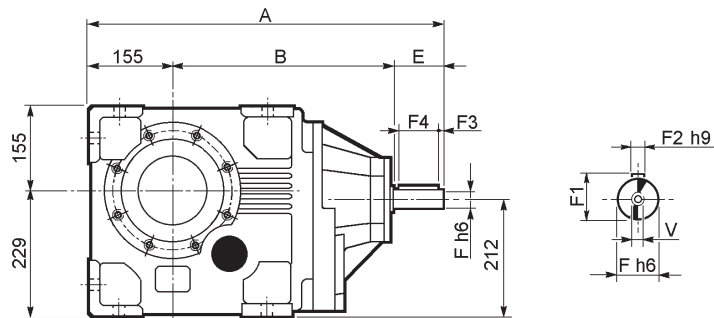

		A	B	E	F	F1	F2	F3	F4	V	
		708.5	443.5	110	42	45	12	10	90	M12x28	165
		644.5	439.5	50	24	27	8	2.5	45	M8x19	149

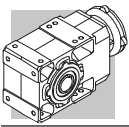

A 70

A 70...UR

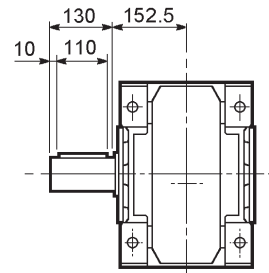
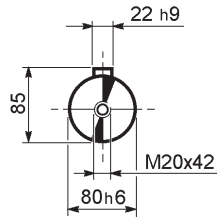

A 70...UD

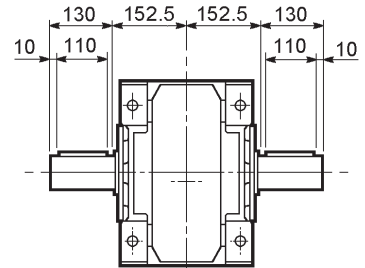
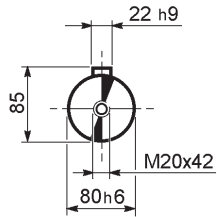

A 70...UH

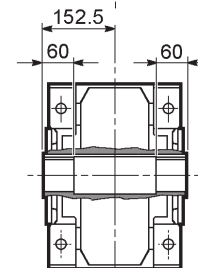
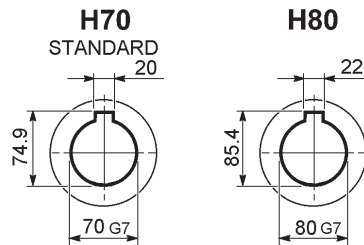

A 70...US

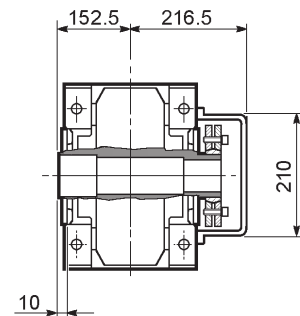
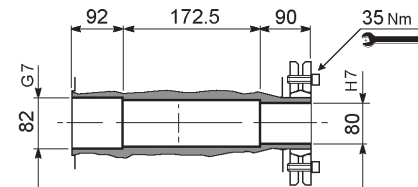

A 70...F...

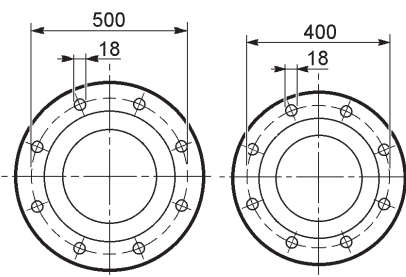
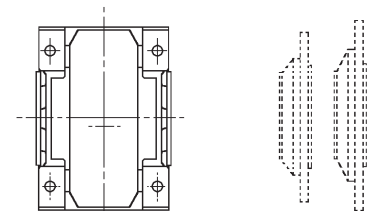
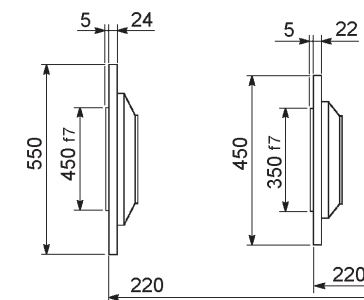

B

A

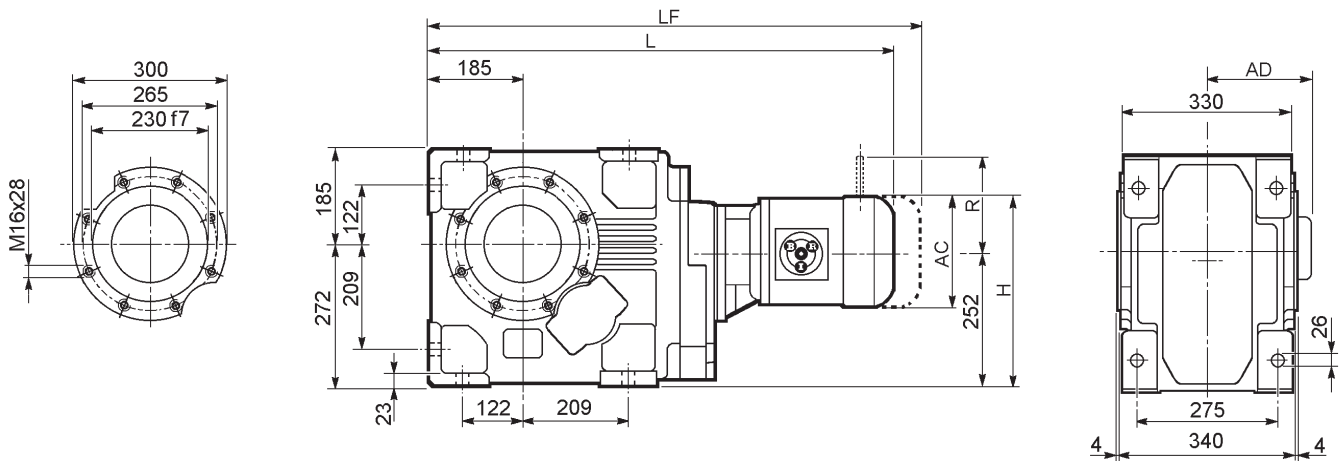
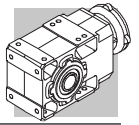
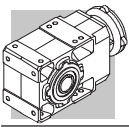
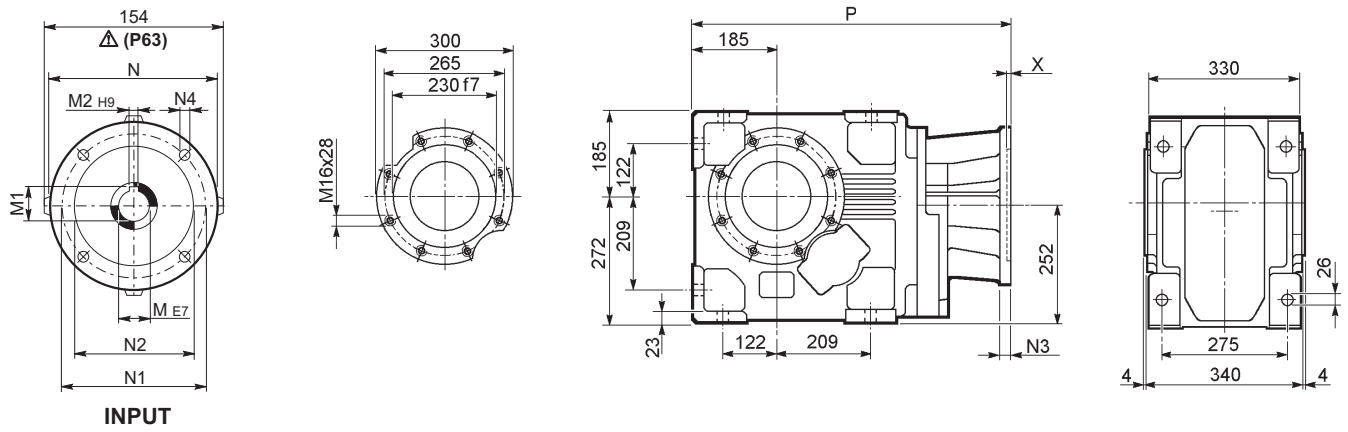

Image	S	M	AC	H	L	AD	Kg	M_FD M_FA		M_FD		M_FA	
								LF	Kg	R	AD	R	AD
	S3	M3S	195	349.5	809.5	142	256	905.5	264	160	158	160	142
	S3	M3L	195	349.5	841.5	142	264	932.5	271	160	158	160	142
	S4	M4	258	381	949.5	193	298	1058.5	316	226	210	217	193
	S4	M4LC	258	381	984.5	193	306	1083.5	324	226	210	217	193
	S5	M5S	310	407	1036	245	326	1176	356	266	245	247	245
	S5	M5L	310	407	1080	245	342	1220	372	266	245	247	245
	S1	M1	138	321	800.5	108	246	861.5	249	103	135	124	108
	S2	M2S	156	330	829.5	119	250	899.5	254	129	146	134	119
	S3	M3S	195	349.5	872.5	142	255	968.5	262	160	158	160	142
	S3	M3L	195	349.5	904.5	142	262	995.5	269	160	158	160	142
	S4	M4	258	381	1012.5	193	296	1121.5	314	226	210	217	193
	S4	M4LC	258	381	1047.5	193	304	1146.5	322	226	210	217	193



A 80...P(IEC)



INPUT

		M	M1	M2	N	N1	N2	N3	N4	X	P	kg
		19	21.8	6	200	165	130	—	M10x12	4	602	243
		24	27.3	8	200	165	130	—	M10x12	4	602	243
		28	31.3	8	250	215	180	—	M12x16	4.5	612	245
		28	31.3	8	250	215	180	—	M12x16	4.5	612	245
		38	41.3	10	300	265	230	16	14	5	648.5	253
		42	45.3	12	350	300	250	23	18	6	704	268
		48	51.8	14	350	300	250	23	18	6	704	268
		55	59.3	16	400	350	300	—	M16x25	7	729	279
		60	64.4	18	450	400	350	25	18	6	774.5	298
		11	12.8	4	140	115	95	—	M8x19	4	645.5	248
		14	16.3	5	160	130	110	—	M8x16	4.5	645.5	248
		19	21.8	6	200	165	130	—	M10x12	4	665	249
		24	27.3	8	200	165	130	—	M10x12	4	665	249
		28	31.3	8	250	215	180	—	M12x16	4.5	675	250
		28	31.3	8	250	215	180	—	M12x16	4.5	675	250
		38	41.3	10	300	265	230	16	M12x16	5	711.5	259

A 80...HS

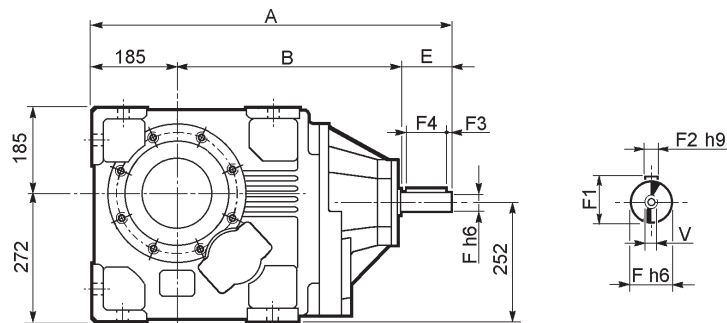

		A	B	E	F	F1	F2	F3	F4	V	kg
		786.5	491.5	110	42	45	12	10	90	M12x28	265
		735	499	50	24	27	8	2.5	45	M8x19	250

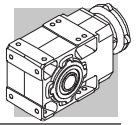

A 80...UR

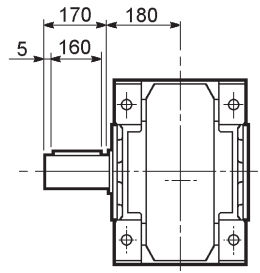
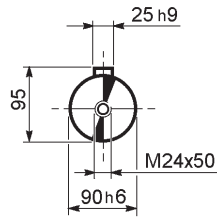

A 80...UD

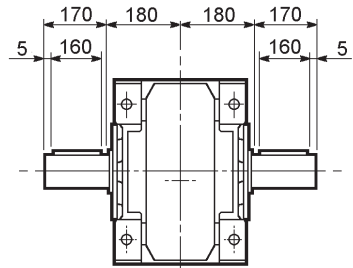
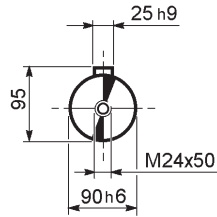

A 80...UH

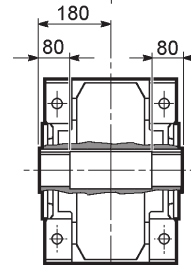
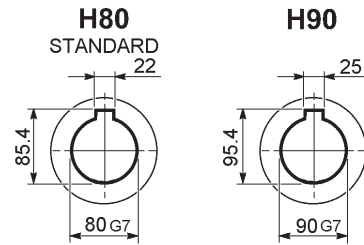

A 80...US

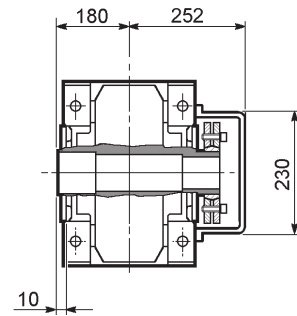
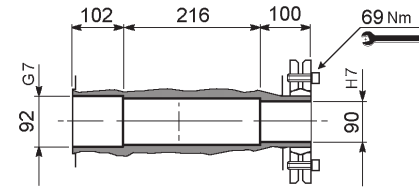

A 80...F...

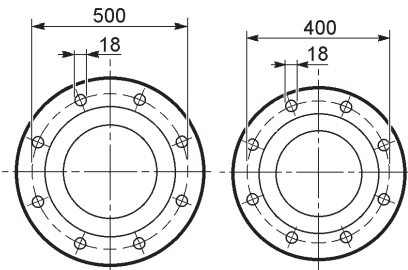
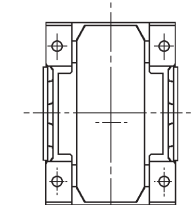
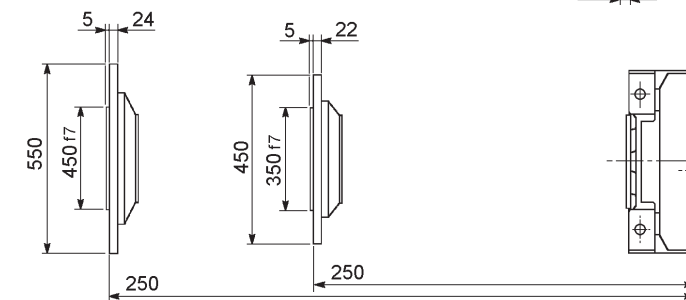

B

A

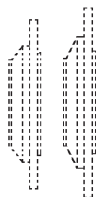

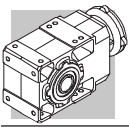

A 90...M

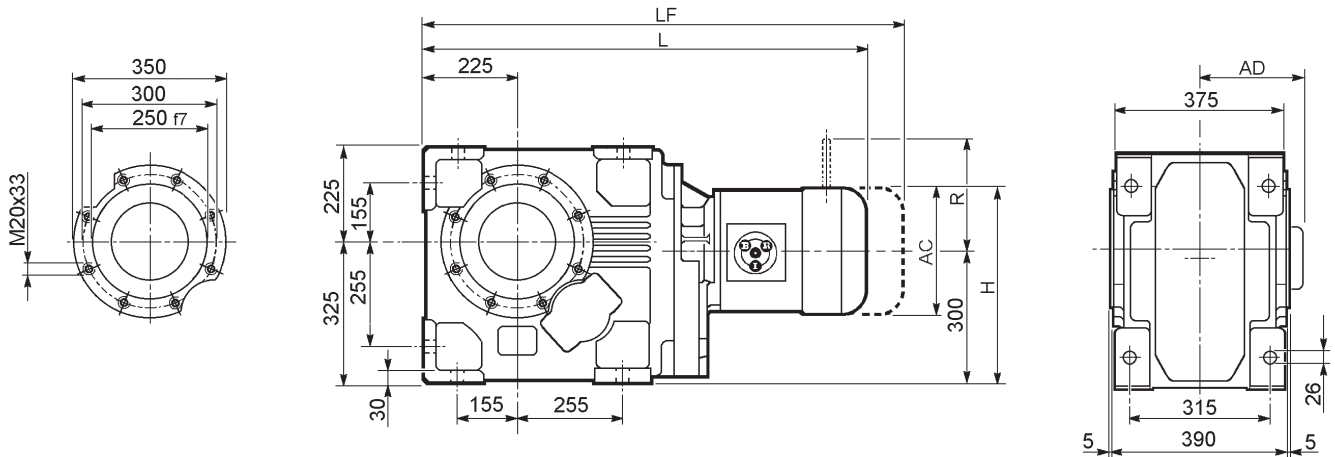

			AC	H	L	AD	Kg	M_FD M_FA		M_FD		M_FA	
								LF	Kg	R	AD	R	AD
A 90 3	S3	M3S	195	397.5	930.5	142	413	1026.5	420	160	158	160	142
A 90 3	S3	M3L	195	397.5	962.5	142	420	1053.5	427	160	158	160	142
A 90 3	S4	M4	258	429	1070.5	193	454	1179.5	472	226	210	217	193
A 90 3	S4	M4LC	258	429	1105.5	193	462	1204.5	480	226	210	217	193
A 90 3	S5	M5S	310	455	1157	245	482	1297	512	266	245	247	245
A 90 3	S5	M5L	310	455	1201	245	498	1341	528	266	245	247	245
A 90 4	S1	M1	138	369	941.5	108	412	1002.5	249	103	135	124	108
A 90 4	S2	M2S	156	378	970.5	119	422	1040.5	426	129	146	134	119
A 90 4	S3	M3S	195	397.5	1013.5	142	427	1109.5	434	160	158	160	142
A 90 4	S3	M3L	195	397.5	1045.5	142	434	1136.5	441	160	158	160	142
A 90 4	S4	M4	258	429	1153.5	193	468	1262.5	486	226	210	217	193
A 90 4	S4	M4LC	258	429	1188.5	193	476	1287.5	494	226	210	217	193

A 90...P(IEC)

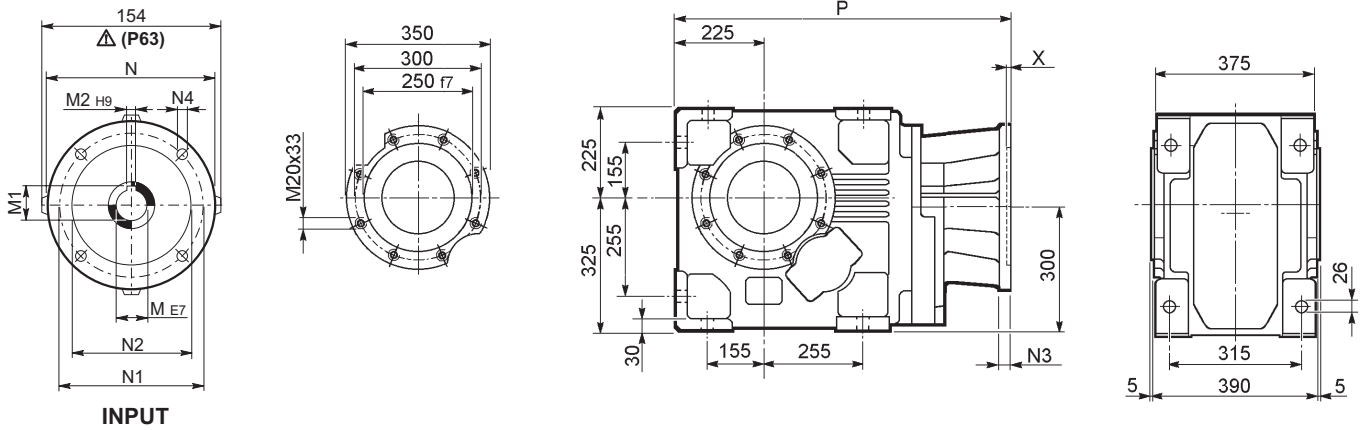
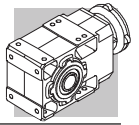

INPUT

		M	M1	M2	N	N1	N2	N3	N4	X	P	
		19	21.8	6	200	165	130	—	M10x12	4	723	400
		24	27.3	8	200	165	130	—	M10x12	4	723	400
		28	31.3	8	250	215	180	—	M12x16	4.5	733	401
		28	31.3	8	250	215	180	—	M12x16	4.5	733	401
		38	41.3	10	300	265	230	16	14	5	769.5	409
		42	45.3	12	350	300	250	23	18	6	825	428
		48	51.8	14	350	300	250	23	18	6	825	429
		55	59.3	16	400	350	300	—	M16x25	7	850	436
		60	64.4	18	450	400	350	30	18	6	895.5	472
		65	69.4	18	550	500	450	30	18	6	925.5	475
		11	12.8	4	140	115	95	—	M8x19	4	786.5	411
		14	16.3	5	160	130	110	—	M8x16	4.5	786.5	412
		19	21.8	6	200	165	130	—	M10x12	4	806	413
		24	27.3	8	200	165	130	—	M10x12	4	806	413
		28	31.3	8	250	215	180	—	M12x16	4.5	816	415
		28	31.3	8	250	215	180	—	M12x16	4.5	816	415
		38	41.3	10	300	265	230	16	14	5	852.5	423
		42	45.3	12	350	300	250	23	18	5.5	903	434
		48	51.8	14	350	300	250	23	18	5.5	903	434

A 90...HS

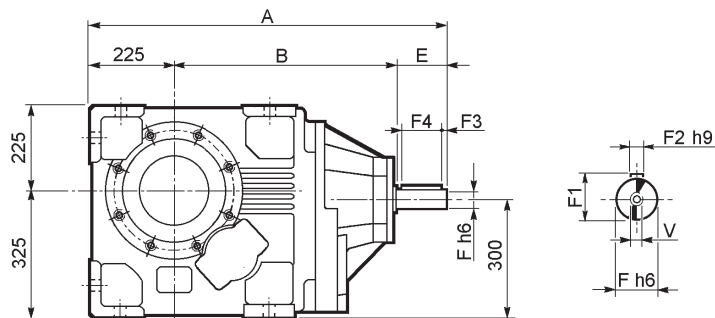

		A	B	E	F	F1	F2	F3	F4	V	
		1009	644	140	60	64	18	10	120	M16x36	465
		875.5	600.5	50	24	27	8	2.5	45	M8x19	415

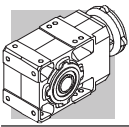

A 90

A 90...UR

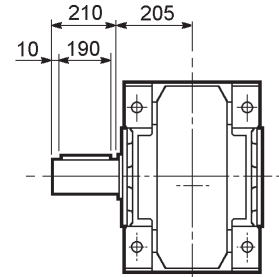
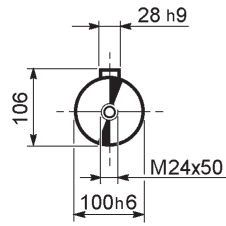

A 90...UD

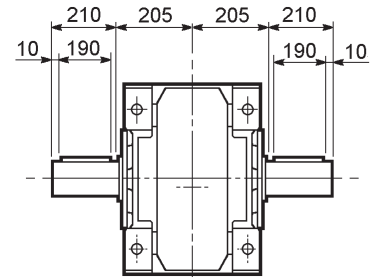
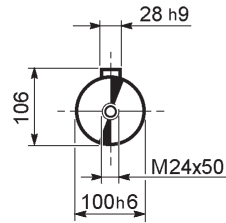

A 90...UH

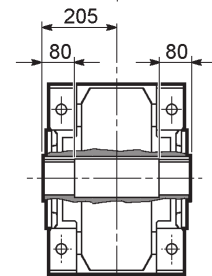
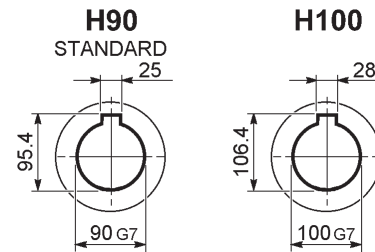

A 90...US

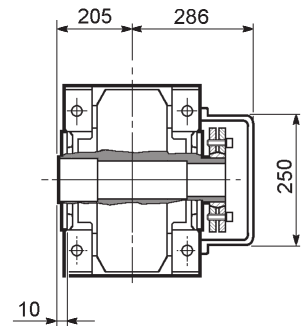
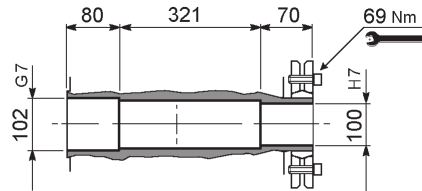

A 90...F...

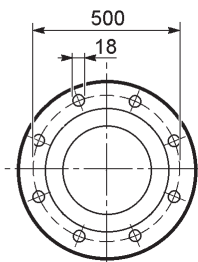
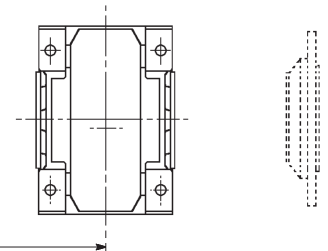
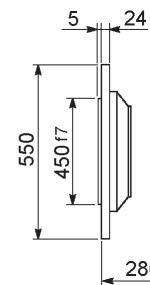

A

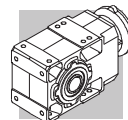

35 - ACCESSORI

35 - ACCESSORIES

35 - ZUBEHÖR

35 - ACCESSOIRES

Albero lento riportato A 05

Per il riduttore A 05 è disponibile un kit albero lento contenente: albero, anello elastico, rondella e chiavette, sia in esecuzione monolaterale (**kit albero lento semplice A 05**) che bilaterale (**kit albero lento doppio A 05**).

L'albero semplice può essere montato su entrambi i lati del riduttore e non richiede nessuna particolare attrezzatura.

A05 plug-in solid output shaft

For gear unit A 05 a plug-in solid shaft is available as a mounting kit including shaft, snap ring, washer and parallel keys in both the single (**A 05 single o/p shaft**) and the double extension (**A 05 double o/p shaft**) configuration.

Shaft can be configured as either left- or right-hand and does not require any particular tooling.

Zapfenwelle ins Getriebe eingesteckt

Für Getriebe Größe A 05 sind Steckwelle inklusive Sicherungsring, Unterlegscheibe und Passfeder als einseitige (**Kit A 05 einseitige Steckwelle**) oder zweiseitige (**Kit A 05 zweiseitige Steckwelle**) Ausführung verfügbar.

Die Montage kann auf der rechten oder linken Seite erfolgen und erfordert kein spezielles Werkzeug.

Arbre lent rapporté A05

Pour le réducteur A 05 est disponible un kit pour l'arbre lent comprenant : arbre, circlips, rondelle et clavettes. Le kit existe pour les exécutions « arbre lent simple » (**kit arbre lent simple A 05**) et « arbre lent double » (**kit arbre lent double A 05**).

L'arbre simple peut être monté sur chacun des deux cotés et son montage ne demande aucun outillage spécifique.

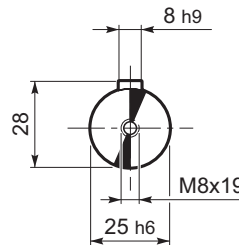
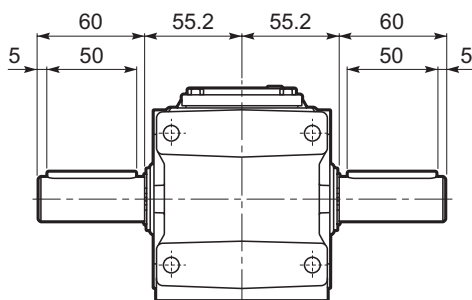
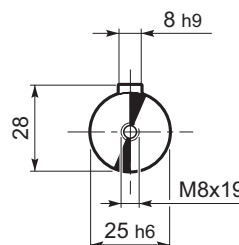
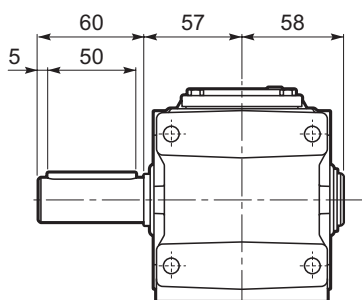

Coperchio di sicurezza

Safety cover

Sicherheit Abdecken

Couverture de sécurité

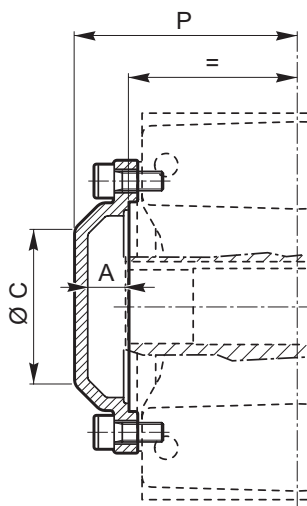

	A	Ø C	P
A 05	17.5	36	73.5
A 10	20.5	60	84.5
A 20	20	75	94
A 30	20	75	104
A 35	19.5	80	114
A 41	21	110	120
A 50	26	100	148.5
A 55	27	100	149
A 60	25	100	158
A 70	33.5	120	193.5
A 80	38	140	228
A 90	43	152	258

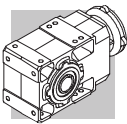

Braccio di reazione

Torque arm

Drehmomentstütze

Bras de réaction

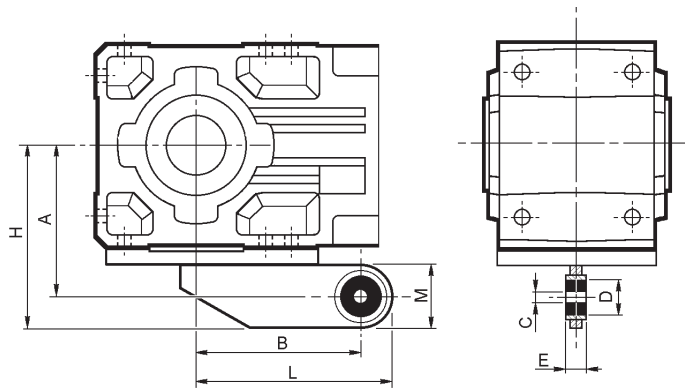

	A	B	C	D	E	H	L	M
A 05	90.5	80	10	30	20	115.5	105	50
A 10	108	118	10	30	20	138	148	60
A 20	118	137	10	30	20	148	167	60
A 30	135	150	20	40	25	170	185	70
A 35	145	165	20	40	25	180	200	70
A 41	157	200	20	40	25	192	235	70
A 50	200	250	32	56	40	245	295	90
A 55	200	250	32	56	40	245	295	90
A 60	225	300	32	56	40	270	345	90

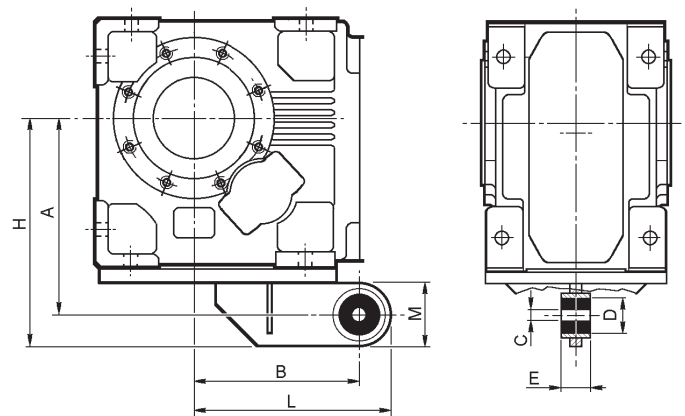

	A	B	C	D	E	H	L	M
A 70	289	250	32	56	40	334	295	90
A 80	357	300	42	78	60	422	365	130
A 90	410	350	42	78	60	475	415	130

Il braccio di reazione viene fornito completo di vite per il fissaggio.

Torque arm comes complete with fastening bolt.

Mit der Drehmomentstütze wird die entsprechende Befestigungsschraube mitgeliefert.

Le bras de réaction est fourni avec vis de serrage.

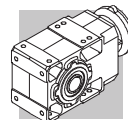

36 - ALBERO MACCHINA

36 - CUSTOMER' SHAFT

36 - MASCHINACHSE

36 - ARBRE MACHINE

Si consiglia di realizzare l'albero condotto che si accoppierà con il riduttore con un acciaio di buona qualità, rispettando le dimensioni riportate in tabella.

Si suggerisce inoltre di completare il montaggio con un dispositivo di bloccaggio assiale dell'albero, ad esempio come illustrato nel seguito, avendo cura di verificare e dimensionare i vari componenti in funzione delle diverse esigenze applicative.

Make the driven shaft to be coupled to the gear unit's output shaft from a good quality steel, respecting the dimensions given in the table.

A device such as that illustrated below should also be installed to secure the shaft axially. Take care to verify and dimension the various components to suit the needs of the application.

Die angetriebene und mit dem Getriebe gepaarte Welle sollte aus hochwertigem Stahl gemäß den Abmessungen der Tabelle gefertigt werden.



Darüber hinaus sollte der Einbau mit einer axialen Sperrvorrichtung der Welle vervollständigt werden, siehe folgendes Beispiel, hierbei die einzelnen Komponenten in Abhängigkeit der verschiedenen Anwendungserfordernisse überprüfen und dimensionieren.

Nous conseillons de réaliser l'arbre mené d'accouplement avec le réducteur avec de l'acier de bonne qualité et de respecter les dimensions indiquées sur le tableau.

Il est recommandé de compléter le montage par un dispositif de blocage axial de l'arbre, à titre d'exemple voir comme illustré ci-dessous, en prenant soin de vérifier et de dimensionner les divers composants en fonction des différentes exigences d'application.

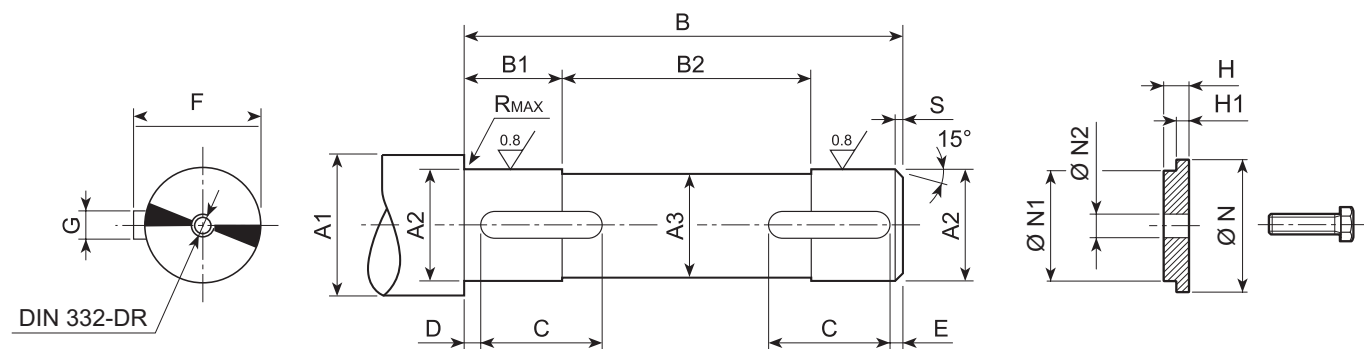
UH



	A1	A2	A3	B	B1	B2	C	D	E	F	G	R	S		N	N1	N2	H	H1	
A05 UH25	≥ 30	25 h7	24	102	21	62	20	2	2	28	8 h9	0.5	1.5	UNI 6604	35	25 d9	9	7	5.5	M8x25
A10 UH30	≥ 35	30 h7	29	118	16	87	20	2	2	33	8 h9	0.5	1.5	UNI 6604	35	30 d9	11	8.5	7	M10x30
A10 UH25	≥ 30	25 h7	24	118	16	87	20	2	2	28	8 h9	0.5	1.5	UNI 6604	30+35	25 d9	9	7	5.5	M8x25
A20 UH35	≥ 42	35 h7	34	138	20	98	20	2	2	38	10 h9	0.5	1.5	UNI 6604	42	35 d9	11	8.5	7	M10x30
A20 UH30	≥ 35	30 h7	29	138	20	98	25	2	2	33	8 h9	0.5	1.5	UNI 6604	35+42	30 d9	11	8.5	7	M10x30
A30 UH40	≥ 47	40 h7	39	158	23	112	30	2	2	43	12 h9	0.5	1.5	UNI 6604	47	40 d9	14	8.5	7	M12x35
A30 UH35	≥ 42	35 h7	34	158	23	112	30	2	2	38	10 h9	0.5	1.5	UNI 6604	42+47	35 d9	11	8.5	7	M10x30
A35 UH40	≥ 47	40 h7	39	175	33	109	40	2	2	43	12 h9	1	1.5	UNI 6604	47	40 d9	14	8.5	7	M12x35
A35 UH35	≥ 42	35 h7	34	175	33	109	40	2	2	38	10 h9	1	1.5	UNI 6604	42+47	35 d9	11	8.5	7	M10x30
A41 UH45	≥ 52	45 h7	44	184	28	128	45	2.5	2.5	49.5	14 h9	1	2	UNI 6604	52	45 d9	14	8.5	7	M12x35
A41 UH40	≥ 47	40 h7	39	184	28	128	50	2.5	2.5	43	12 h9	1	2	UNI 6604	47+52	40 d9	14	8.5	7	M12x35
A50 UH55	≥ 63	55 h7	54	226	37.5	151	55	2.5	2.5	59	16 h9	1	2	UNI 6604	63	55 d9	22	10	8	M20x50
A50 UH50	≥ 57	50 h7	49	226	37.5	151	65	2.5	2.5	53.5	14 h9	1	2	UNI 6604	57+63	50 d9	18	10	8	M16x45
A55 UH60	≥ 70	60 h7	59	226	37.5	151	65	2.5	2.5	64	18 h9	2	2	UNI 6604	70	60 d9	22	10	8	M20x50
A55 UH50	≥ 60	50 h7	49	226	37.5	151	75	2.5	2.5	53.5	14 h9	2	2	UNI 6604	60+70	50 d9	18	10	8	M16x45
A60 UH70	≥ 78	70 h7	69	248	48	152	70	2.5	2.5	74.5	20 h9	2.5	2	UNI 6604	78	70 d9	22	10	8.5	M20x50
A60 UH60	≥ 68	60 h7	59	248	48	152	80	2.5	2.5	64	18 h9	2.5	2	UNI 6604	68+78	60 d9	22	10	8.5	M20x50
A70 UH80	≥ 89	80 h7	79	303	58	187	90	3	3	85	22 h9	2.5	2.5	UNI 6604	89	80 d9	22	10	8.5	M20x50
A70 UH70	≥ 78	70 h7	69	303	58	187	110	3	3	74.5	20 h9	2.5	2.5	UNI 6604	78+89	70 d9	22	10	8.5	M20x50
A80 UH90	≥ 99	90 h7	89	358	78	202	120	3	3	95	25 h9	2.5	2.5	UNI 6604	99	90 d9	26	22	20.5	M24x70
A80 UH80	≥ 89	80 h7	79	358	78	202	130	3	3	85	22 h9	2.5	2.5	UNI 6604	89+99	80 d9	22	10	8.5	M20x50
A90 UH100	≥ 111	100 h7	99	408	78	252	160	3	3	106	28 h9	2.5	2.5	UNI 6604	111	100 d9	26	22	20.5	M24x70
A90 UH90	≥ 99	90 h7	89	408	78	252	190	3	3	95	25 h9	2.5	2.5	UNI 6604	99+111	90 d9	26	22	20.5	M24x70

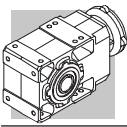

US

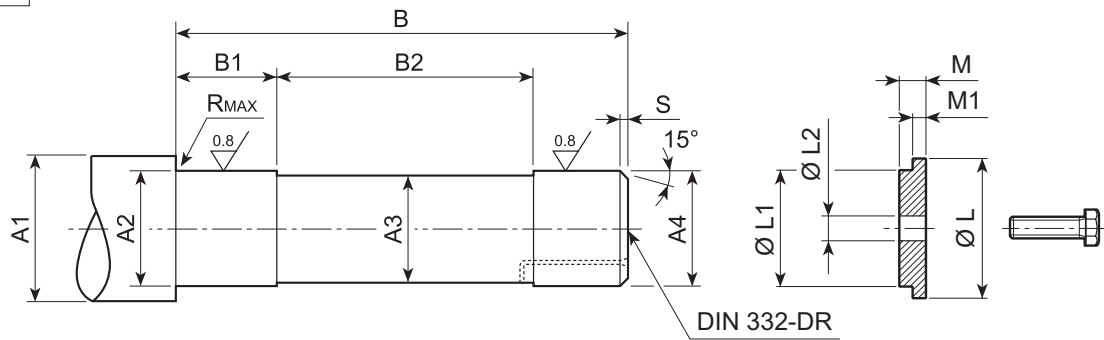

	A1	A2	A3	A4	B	B1	B2	R	S	L	L1	L2	M	M1	UNI 5739
A 05	≥ 35	27 h7	24	25 h6	129.5	32	63.5	0.5	1.5	29.5	25 d9	11	8.5	7	M10x30
A 10	≥ 42	32 h7	29	30 h6	147.5	34	77.5	0.5	1.5	35.5	30 d9	11	8.5	7	M10x30
A 20	≥ 48	37 h7	34	35 h6	170	40	89	0.5	1.5	43	35 d9	14	8.5	7	M12x35
A 30	≥ 54	42 h7	39	40 h6	191.5	48	95.5	0.5	1.5	49	40 d9	18	10	8.5	M16x45
A 35	≥ 54	42 h7	39	40 h6	208.5	48	112.5	0.5	1.5	49	40 d9	18	10	8.5	M16x45
A 41	≥ 60	47 h7	44	45 h6	222	53	117	1	2	54	45 d9	18	10	8.5	M16x45
A 50	≥ 72	57 h7	54	55 g6	264	46	156	1	2	72	55 d9	22	10	8.5	M20x50
A 55	≥ 72	62 h7	59	60 g6	266	46	158	2.5	2	72	60 d9	22	10	8.5	M20x50
A 60	≥ 90	72 h7	69	70 g6	293	48	178	2.5	2.5	85	70 d9	22	10	8.5	M20x50
A 70	≥ 104	82 h7	79	80 g6	352.5	90	172.5	2.5	2.5	95	80 d9	22	10	8.5	M20x50
A 80	≥ 114	92 h7	89	90 g6	416	100	216	2.5	2.5	105	90 d9	26	22	20.5	M24x70
A 90	≥ 126	102 h7	99	100 g6	469	78	321	2.5	2.5	120	100 d9	26	22	20.5	M24x70

UV

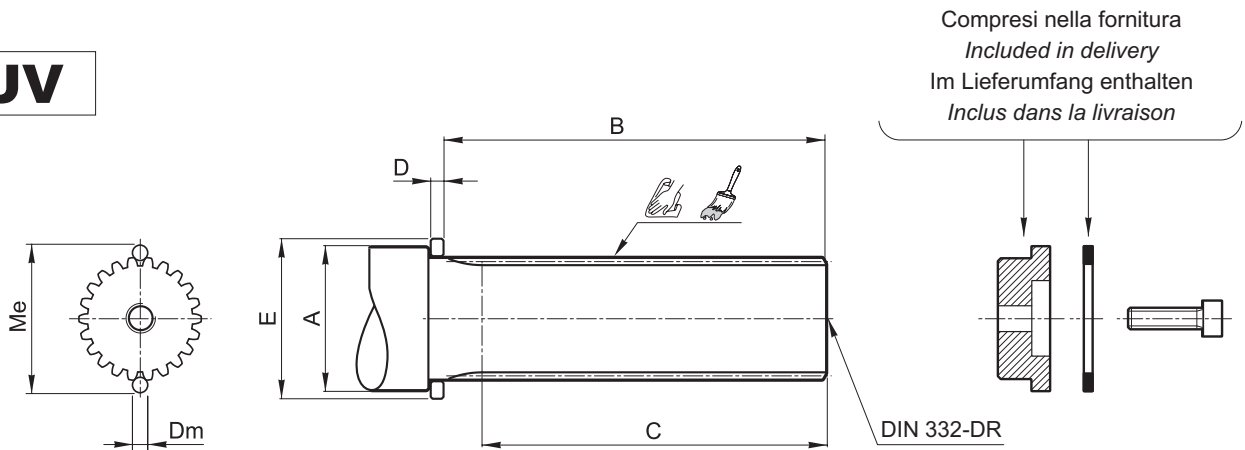

	DIN 5480	Me	Dm	A	B	C	D	E	ISO 4762
A 20	30x1.25x30x22	33.04 +0/-0.04	2.75	≥ 40	111.5	≥ 95	7	45	M10x35
A 30	35x2x30x16	38.93 +0/-0.04	4	≥ 45	130.5	≥ 112	7	50	M12x40
A 35	35x2x30x16	38.93 +0/-0.04	4	≥ 45	147.5	≥ 129	7	50	M12x40
A 41	45x2x30x21	48.86 +0/-0.04	4	≥ 55	155.5	≥ 136	7	60	M16x45
A 50	50x2x30x24	54.14 +0/-0.05	4	≥ 60	196	≥ 175	7	65	M16x45
A 55	50x2x30x24	54.14 +0/-0.05	4	≥ 60	196	≥ 175	7	65	M16x45
A 60	65x2x30x31	68.97 +0/-0.05	4	≥ 75	213.5	≥ 191	7	80	M20x55

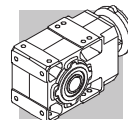

QF

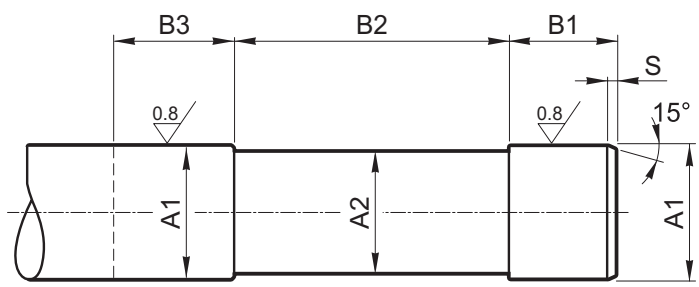

		A1	A2	B1	B2	B3	S
A 10	QF25	25 h6	24	41	95	≥ 50	1.5
	QF30	30 h6	29				
A 20	QF25	25 h6	24	41	115	≥ 50	1.5
	QF30	30 h6	29				
A 30	QF35	35 h6	34	45	130	≥ 54	1.5
	QF40	40 h6	39				
A 35	QF35	35 h6	34	45	146.5	≥ 54	1.5
	QF40	40 h6	39				
A 41	QF40	40 h6	39	47	151.5	≥ 56	2
	QF45	45 h6	44				
A 50	QF50	50 h6	49	48	197	≥ 57	2
	QF55	55 h6	54				
A 55	QF55	55 h6	54	50	190	≥ 59	2
	QF60	60 h6	59				
A 60	QF60	60 h6	59	57	203	≥ 66	2.5
	QF65	65 h6	64				
	QF70	70 h6	69				

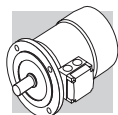
MOTORI ELETTRICI
ELECTRIC MOTORS
ELEKTROMOTOREN
**MOTEURS
ELECTRIQUES**
**M1 - SIMBOLOGIA E
UNITÀ DI MISURA**
**M1 - SYMBOLS AND UNITS
OF MEASUREMENT**
**M1 - SYMBOLE UND
MAßEINHEITEN**
**M1 - SYMBOLES ET UNITES
DE MESURE**

Simb. Symb.	U.m. Einheit	Descrizione	Description	Beschreibung	Description
$\cos\varphi$	–	Fattore di potenza	Power factor	Leistungsfaktor	Facteur de puissance
η	–	Rendimento	Efficiency	Wirkungsgrad	Rendement
f_m	–	Fattore correttivo della potenza	Power adjusting factor	Leistungskorrekturfaktor	Facteur de correction de la puissance
I	–	Rapporto di intermittenza	Cyclic duration factor	Relative Einschaltdauer	Rapport d'intermittence
I_N	[A]	Corrente nominale	Rated current	Nennstrom	Courant nominal
I_S	[A]	Corrente di spunto	Locked rotor current	Kurzschlußstrom	Courant de démarrage
J_C	[Kgm ²]	Momento di inerzia del carico	Load moment of inertia	Massenträgheitsmoment der externen Massen	Moment d'inertie de la charge
J_M	[Kgm ²]	Momento di inerzia motore	Moment of inertia	Trägheitsmoment	Moment d'inertie du moteur
K_C	–	Fattore di coppia	Torque factor	Drehmomentfaktor	Facteur de couple
K_d	–	Fattore di carico	Load factor	Lastfaktor	Facteur de charge
K_J	–	Fattore di inerzia	Inertia factor	Trägheitsfaktor	Facteur d'inertie
M_A	[Nm]	Coppia accelerante media	Mean breakaway torque	Losbrechmoment	Couple d'accélération moyen
M_B	[Nm]	Coppia frenante	Brake torque	Bremsemoment	Couple du frein
M_N	[Nm]	Coppia nominale	Rated torque	Nennmoment	Couple nominal
M_L	[Nm]	Coppia resistente media	Counter-torque during acceleration	Lastmoment	Couple résistant moyen
M_S	[Nm]	Coppia di spunto	Starting torque	Startmoment	Couple de démarrage
n	[min ⁻¹]	Velocità nominale	Rated speed	Nenndrehzahl	Vitesse nominale
P_B	[W]	Potenza assorbita dal freno a 20°C	Power drawn by the brake at 20°C	Leistungsaufnahme der Bremse bei 20°C	Puissance absorbée par le frein à 20°C
P_n	[kW]	Potenza nominale	Motor rated power	Nennleistung	Puissance nominale
P_r	[kW]	Potenza richiesta	Required power	Benötigte Leistung	Puissance nécessaire
t₁	[ms]	Ritardo di sblocco del freno con alimentatore a semionda	Brake response time with one-way rectifier	Ansprechzeit Bremse mit Einweg-Gleichrichter	Temps de déblocage du frein avec alimentation à demi-onde
t_{1s}	[ms]	Tempo di sblocco del freno con alimentatore a controllo elettronico	Brake response time with electronic-controlled rectifier	Ansprechzeit Bremse mit elektronisch gesteuertem Gleichrichter	Temps de déblocage du frein avec alimentation à contrôle électronique
t₂	[ms]	Ritardo di frenatura con disgiunzione lato c.a.	Brake reaction time with a.c. disconnect	Einfallzeit Bremse bei Unterbrechung der Stromversorgung WS	Retard de freinage avec coupure coté c.a.
t_{2c}	[ms]	Ritardo di frenatura con disgiunzione circuito c.a. e c.c.	Brake reaction time with a.c. and d.c. disconnect	Einfallzeit Bremse bei Unterbrechung der Stromversorgung WS und GS	Retard de freinage avec coupure coté c.a. et c.c.
t_a	[°C]	Temperatura ambiente	Ambient temperature	Umgebungstemperatur	Température ambiante
t_f	[min]	Tempo di funzionamento a carico costante	Work time at constant load	Betriebsdauer unter Nennbelastung	Temps de fonctionnement à charge constante
t_r	[min]	Tempo di riposo	Rest time	Aussetzzeit	Temps de repos
W	[J]	Lavoro di frenatura accumulato tra due regolazioni del traferro	Braking work between service interval	Bremsenergie zwischen zwei Einstellungen	Energie de freinage accumulée entre deux réglages de l'entrefer
W_{max}	[J]	Energia massima per singola frenatura	Maximum brake work for each braking	Max. Bremsarbeit pro Bremsvorgang	Energie maxi par freinage
Z	[1/h]	N° di avviamenti ammissibili, a carico	Permissible starting frequency, loaded	Schalzhäufigkeit Nennbetrieb	Nombre de démarrages admissibles en charge
Z₀	[1/h]	N° di avviamenti ammissibili a vuoto (I = 50%)	Max. permissible unloaded starting frequency (I = 50%)	Max. Schalzhäufigkeit im Leerlauf (relative Einschalt-dauer I = 50%)	Nombre de démarrages admissible à vide (I = 50%)

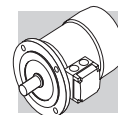

M2 - CARATTERISTICHE GENERALI

Programma di produzione

I motori elettrici asincroni trifase del programma di produzione della BONFIGLIOLI RIDUTTORI sono previsti nelle forme costruttive base IMB5, IMB14 e loro derivate con le seguenti polarità: 2, 4, 6, 2/4, 2/6, 2/8, 2/12. Nel presente catalogo sono evidenziate inoltre, le caratteristiche tecniche dei motori in versione integrata, tipo M.

M2 - GENERAL CHARACTERISTICS

Production range

The asynchronous three-phase electric motors of BONFIGLIOLI RIDUTTORI's production, are available in basic designs IMB5 and IMB14 and derived versions, with the following polarities: 2, 4, 6, 2/4, 2/6, 2/8, 2/12. The technical characteristics of compact motors, M type, are also supplied in this manual.

M2 - ALLGEMEINE EIGENSCHAFTEN

Produktprogramm

Die Dreiphasen-Asynchronmotoren aus dem Produktprogramm von BONFIGLIOLI RIDUTTORI gibt es in den Grundbauformen IMB5, IMB14 und deren Ableitungen mit folgenden Polzahlen: 2, 4, 6, 2/4, 2/6, 2/8 und 2/12. Im vorliegenden Katalog sind außerdem die technischen Eigenschaften der Motoren in Kompaktausführung hervorgehoben.

M2 - CARACTERISTIQUES GENERALES

Programme de production

Les moteurs électriques asynchrones triphasés du programme de production de BONFIGLIOLI RIDUTTORI sont prévus dans les formes de construction de base IMB5, IMB14 et leur dérivés avec les polarités suivantes: 2, 4, 6, 2/4, 2/6, 2/8, 2/12. Dans le présent catalogue sont également mises en évidence les caractéristiques techniques des moteurs en version compacte, type M.

Normative

I motori descritti in questo catalogo sono costruiti in accordo alle Norme ed unificazioni applicabili evidenziate nella tabella seguente.

Standards

The motors described in this catalogue are manufactured to the applicable standards shown in the following table.

Normen

Die in diesem Katalog beschriebenen Motoren sind in Übereinstimmung mit den in der folgenden Tabelle angegebenen einschlägigen Normen und Vereinheitlichungsrichtlinien konstruiert worden.

Réglementations

Les moteurs décrits dans ce catalogue sont construits en accord avec les Normes et standardisations applicables mises en évidence dans le tableau ci-dessous.

(A26)

Titolo / Title / Titel / Titre	CEI	IEC
Prescrizioni generali per macchine elettriche rotanti <i>General requirements for rotating electrical machines</i> Allgemeine Vorschriften für umlaufende elektrische Maschinen <i>Prescriptions générales pour machines électriques tournantes</i>	CEI EN 60034-1	IEC 60034-1
Marcatura dei terminali e senso di rotazione per macchine elettriche rotanti <i>Terminal markings and direction of rotation of rotating machines</i> Kennzeichnung der Anschlußklemmen und Drehrichtung von umlaufenden elektrischen Maschinen <i>Définitions des bornes et sens de rotation pour machines électriques tournantes</i>	CEI 2-8	IEC 60034-8
Metodi di raffreddamento delle macchine elettriche <i>Methods of cooling for electrical machines</i> Verfahren zur Kühlung von elektrischen Maschinen <i>Méthodes de refroidissement des machines électriques</i>	CEI EN 60034-6	IEC 60034-6
Dimensioni e potenze nominali per macchine elettriche rotanti <i>Dimensions and output ratings for rotating electrical machines</i> Auslegung der Nennleistung von umlaufenden elektrischen Maschinen <i>Dimensions, puissances nominales pour machines électriques tournantes</i>	EN 50347	IEC 60072
Classificazione dei gradi di protezione delle macchine elettriche rotanti <i>Classification of degree of protection provided by enclosures for rotating machines</i> Klassifizierung der Schutzart von umlaufenden elektrischen Maschinen <i>Classification des degrés de protection des machines électriques tournantes</i>	CEI EN 60034-5	IEC 60034-5
Limiti di rumorosità <i>Noise limits</i> Geräuschgrenzwerte <i>Limites de bruit</i>	CEI EN 60034-9	IEC 60034-9
Segne di designazione delle forme costruttive e dei tipi di installazione <i>Classification of type of construction and mounting arrangements</i> Abkürzungen zur Kennzeichnung der Bauform und der Einbaulagen <i>Signes de dénomination des formes de construction et des types d'installation</i>	CEI EN 60034-7	IEC 60034-7
Tensione nominale per i sistemi di distribuzione pubblica dell'energia elettrica a bassa tensione <i>Rated voltage for low voltage mains power</i> Nennspannung für öffentliche NS-Stromverteilungssysteme <i>Tension nominale pour les systèmes de distribution publique de l'énergie électrique en basse tension</i>	CEI 8-6	IEC 60038
Grado di vibrazione delle macchine elettriche <i>Vibration level of electric machines</i> Schwingstärke bei elektrischen Maschinen <i>Degré de vibration des machines électriques</i>	CEI EN 60034-14	IEC 60034-14

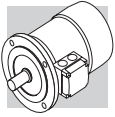

I motori corrispondono inoltre alle Norme straniere adeguate alle IEC 60034-1 e qui riportate.

The motors also comply with foreign standards adapted to IEC 60034-1 as shown here below.

Die Motoren entsprechen außerdem den an die IEC-Norm 60034-1 angepaßten ausländischen Normen, die in der folgenden Tabelle genannt werden.

En outre, les moteurs correspondent aux Normes étrangères adaptées aux IEC 60034-1 indiquées dans le tableau ci-dessous.

(A27)

DIN VDE 0530	Germania	Germany	Deutschland	Allemagne
BS5000 / BS4999	Gran Bretagna	Great Britain	Großbritannien	Grande Bretagne
AS 1359	Australia	Australia	Australien	Australie
NBNC 51 - 101	Belgio	Belgium	Belgien	Belgique
NEK - IEC 34	Norvegia	Norway	Norwegen	Norvège
NF C 51	Francia	France	Frankreich	France
OEVE M 10	Austria	Austria	Österreich	Autriche
SEV 3009	Svizzera	Switzerland	Schweiz	Suisse
NEN 3173	Paesi Bassi	Netherlands	Niederlande	Pays Bas
SS 426 01 01	Svezia	Sweden	Schweden	Suède

CUS

MOTORI PER USA E CANADA

MOTORS FOR USA AND CANADA

MOTOREN FÜR DIE USA UND KANADA

MOTEURS POUR ETATS-UNIS ET CANADA

I motori BN ed M sono disponibili in esecuzione NEMA Design C (per le caratteristiche elettriche), certificata in conformità alle norme CSA (Canadian Standard) C22.2 N° 100 e UL (Underwriters Laboratory) UL 1004 con targhetta riportante entrambi i marchi sotto illustrati, specificare in questo caso l'opzione CUS.

BN and M motors are available in NEMA Design C configuration (concerning electrical characteristics), certified to CSA (Canadian standard) C22.2 No. 100 and UL (Underwriters Laboratory) UL 1004. By specifying the option CUS the name plate is marked with both symbols shown here below.

Die BN/M-Motoren sind in der Ausführung NEMA, Design C (aufgrund der elektrischen Eigenschaften), den Normen CSA (Canadian Standard) C22.2 Nr 100 und UL (Underwriters Laboratory) UL 1004 gemäß zertifiziert. Durch Spezifizieren der Option CUS wird das Typenschild mit den nachstehend aufgeführten Symbolen gekennzeichnet.

Les moteurs BN et M sont disponibles en exécution NEMA Design C (pour les caractéristiques électriques), certifiée conforme aux normes CSA (Canadian Standard) C22.2 N°100 et UL (Underwriters Laboratory) UL 1004 avec une plaque signalétique indiquant chacun des symboles ci-dessous, dans ce cas, spécifier l'option CUS.



Le tensioni delle reti di distribuzione americane e le corrispondenti tensioni nominali da specificare per il motore sono indicate nella tabella seguente:

US power mains voltages and the corresponding rated voltages to be specified for the motor are indicated in the following table:

Die Spannungen der amerikanischen Verteilernetze und die entsprechenden tens-Nennspannungen, die bei den Motoren angegeben werden müssen, können der folgenden Tabelle entnommen werden:

Les tensions des réseaux de distribution américains ainsi que les tensions nominales à spécifier pour le moteur sont indiquées dans le tableau suivant :

(A28)

Frequenza / Frequency Frequenz / Fréquence	Tensione di rete / Mains voltage Netzspannung / Tension de réseau	V _{mot}
60 Hz	208 V	200 V
	240 V	230 V
	480 V	460 V
	600 V	575 V

I motori dotati di collegamento YY/Y (es. 230/460-60; 220/440-60) presentano di serie una morsettiera a 9 terminali.

Motors with YY/Y connection (e.g. 230/460-60; 220/440-60) feature, as standard, a 9-stud terminal board. For same execu-

Motoren mit YY/Y-Anschluss (z.B. 230/460-60; 220/440-60) sind standardmäßig mit 9 Pins auf dem Klemmbrett ausgeführt. Für glei-

Les moteurs avec connexion YY/Y (ex. 230/460-60; 220/440-60) présentent, en standard, une plaque à borne avec 9 bornes. Pour les me-

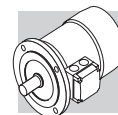

Per le stesse esecuzioni, e inoltre per l'alimentazione 575V-60Hz, la potenza di targa corrisponde a quella normalizzata a 50Hz.

Per i motori autofrenanti con freno in c.c. tipo BN_FD l'alimentazione del raddrizzatore è da morsetteria motore con tensione 230V a.c. monofase.

Per i motori autofrenanti l'alimentazione del freno è così predisposta:

tions, as well as for 575V-60Hz supply, the nominal rating is coincident with the correspondent 50Hz rating.

For DC brake motors type BN_FD, the rectifier is connected to a single-phase 230 VAC supply voltage in the motor terminal box.

Brake power supply for brake motors is as follows:

che Ausführungen, ebenso wie für 575V-60Hz, die Nennleistung ist gleich mit der entsprechenden 50 Hz-Leistung. Für Bremsmotoren mit Gleichstrombremse vom Typ BN_FD erfolgt die Versorgung des Gleichrichters über den Motor-klemmenkasten mit einer Spannung von 230V (einphasiger Wechselstrom). Bei Bremsmotoren stellt sich die **Versorgung der Bremse** wie folgt dar:

mes executions, et aussi pour l'alimentation 575V-60Hz, la puissance de plaque correspond à celle normalisé à 50Hz.

Pour les moteurs frein avec frein en c.c. type BN_FD, l'alimentation du redresseur provient de la boîte à bornes moteur avec une tension 230V c.a. monophasée. Pour les moteurs frein l'alimentation du frein est la suivante :

BN_FD M_FD	BN_FA ; BN_BA M_FA	Specificare / Specify Bitte angeben / Spécifier
Da morsetteria motore 1~230V c.a. Wired to terminal box 1~230V a.c. Vom Motorklemmenkasten 1~230V W.S. Depuis boîte à bornes moteur 1~230V c.a.	Alimentazione separata / Separate power supply Fremdversorgung / Alimentation séparée 230V Δ - 60Hz	230SA
	Alimentazione separata / Separate power supply Fremdversorgung / Alimentation séparée 460V Y - 60Hz	460SA

L'opzione CUS non è applicabile ai motori dotati di servoventilazione.

The option CUS does not apply to servo-ventilated motors.

Die CUS-Option ist für die Fremdlüftermotoren nicht anwendbar.

L'option CUS n'est pas applicable aux moteurs doués de ventilation forcée.

CCC

CHINA COMPULSORY CERTIFICATION

I motori elettrici destinati ad essere commercializzati nella Repubblica Popolare Cinese rientrano nell'applicabilità del sistema di certificazione CCC (China Compulsory Certification). I motori BN con coppia nominale fino a 7Nm sono disponibili con certificazione CCC e targhetta speciale riportante il marchio sotto illustrato:

CHINA COMPULSORY CERTIFICATION

Electric motors destined for sale in the People's Republic of China have to be certified under the CCC (China Compulsory Certification) system. BN motors of up to 7 Nm in rated torque are available with CCC certification and a special nameplate bearing the mark shown below:

CHINA COMPULSORY CERTIFICATION

Die für den Vertrieb in der Volksrepublik China vorgesehenen Elektromotoren fallen unter den Geltungsbereich des Zertifizierungssystems CCC (China Compulsory Certification). Die Motoren der Serie BN mit Nenndrehmoment bis 7 Nm sind mit CCC-Zertifizierung und Sondertypenschild mit der unten dargestellten Marke erhältlich:

CHINA COMPULSORY CERTIFICATION

Les moteurs électriques destinés à être commercialisés dans la République Populaire de Chine rentrent dans le cadre du système de certification CCC (China Compulsory Certification). Les moteurs BN ayant un couple nominal pouvant atteindre 7 Nm sont disponibles avec une certification CCC et une plaque spéciale sur laquelle figure la marque illustrée ci-dessous :



Direttive 2006/95/CE (LVD) e 2004/108/CE (EMC)

I motori delle serie BN ed M sono conformi ai requisiti delle Direttive 2006/95/CE (Direttiva Bassa Tensione) e 2004/108/CE (Direttiva Compatibilità Elettromagnetica), e riportano in targa la marcatura CE.

Per quanto riguarda la Direttiva EMC, la costruzione è in accordo alle Norme CEI EN 60034-1, EN 61000-6-2, EN 61000-6-4.

I motori con freno in c.c. tipo FD, se corredati dell'opportuno filtro capacitivo in ingresso al raddrizzatore (opzione CF), rientrano nei limiti di emissione previsti dalla Norma EN 61000-6-3 "Compa-

Directives 2006/95/EC (LVD) and 2004/108/EC (EMC)

BN and M motors meet the requirements of Directives 2006/95/EC (Low Voltage Directive) and 2004/108/EC (Electromagnetic Compatibility Directive) and their name plates bear the CE mark.

As for the EMC Directive, construction is in accordance with standards CEI EN 60034-1, EN 61000-6-2, EN 61000-6-4.

Motors with FD brakes, when fitted with the suitable capacitive filter at rectifier input (option CF), meet the emission limits required by Standard EN 61000-6-3 "Elec-tromagnetic compatibility - Ge-neric Emission Standard - Part 1:

Richtlinien 2006/95/EG (LVD) und 2004/108/EG (EMC)

Die Motoren der Serie BN und M entsprechen den Anforderungen der Richtlinien 2006/95/EG (Richtlinie - Niederspannung) und 2004/108/EG (Richtlinie - elektromagnetische Kompatibilität) und sind mit dem CE-Zeichen ausgestattet. Im Hinblick auf die Richtlinie EMC entspricht die Konstruktion den Normen CEI EN 60034-1, EN 61000-6-2, EN 61000-6-4.

Die Motoren mit dem Bremstyp FD fallen, falls mit dem entsprechenden kapazitiven Filter am Eingang des Gleichrichters ausgestattet (Option CF), unter die Emissionsgrenzwerte, die von der

Directives 2006/95/CE (LVD) et 2004/108/CE (EMC)

Les moteurs de la série BN et M sont conformes aux conditions requises par les Directives 2006/95/CE (Directive Basse Tension) et 2004/108/CE (Directive Compatibilité Electromagnétique), et le marquage CE est indiqué sur la plaquette signalétique. En ce qui concerne la Directive EMC, la fabrication répond aux Normes CEI EN 60034-1, EN 61000-6-2, EN 61000-6-4.

Les moteurs avec frein FD, s'ils sont équipés du frein capacitif approprié en entrée du redresseur (option CF), rentrent dans les limites d'émission prévues par la

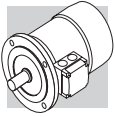

bilità elettromagnetica - Norma Generica sull'emissione - Parte 1: Ambienti residenziali, commerciali e dell'industria leggera". I motori soddisfano inoltre le prescrizioni della Norma CEI EN 60204-1 "Equipaggiamento elettrico delle macchine". È responsabilità del costruttore o dell'assemblatore dell'apparecchiatura che incorpora i motori come componenti garantire la sicurezza e la conformità alle direttive del prodotto finale.

Residential, commercial and light industrial environment". Motors also meet the requirements of standard CEI EN 60204-1 "Electrical equipment of machines". The responsibility for final product safety and compliance with applicable directives rests with the manufacturer or the assembler who incorporate the motors as component parts.

Norm EN 61000-6-3 "Elektromagnetische Kompatibilität - Allgemeine Norm für Emissionen - Teil 1: Wohngebiete, Handels- und Leichtinduszriezonen" vorgesehen werden. Die Motoren entsprechen darüber hinaus den von der Norm CEI EN 60204-1 "Elektrische Maschinenausstattung" gegebenen Vorschriften. Es liegt in der Verantwortung des Herstellers oder es Monteurs der Ausrüstung, in der die Motoren als Komponenten montiert werden, die Sicherheit und die Übereinstimmung mit den Richtlinien des Endprodukts zu gewährleisten.

Norme EN 61000-6-3 "Compatibilité électromagnétique - Norme Générale sur l'émission - Partie 1 : Milieux résidentiels, commerciaux et de l'industrie légère". Les moteurs répondent aussi aux prescriptions de la Norme CEI EN 60204-1 "Equipement électrique des machines". Le fabricant ou le monteur de la machine qui comprend les moteurs comme composant est responsable et doit se charger de garantir la sécurité et la conformité aux directives du produit final.

Tolleranze

Secondo le Norme sono ammesse le tolleranze indicate nella tabella seguente sulle grandezze garantite.

Tolerances

As per the Norms applicable the tolerances here below apply to the following quantities.

Toleranzen

Die Normen lassen die in folgenden Tabelle genannten Toleranzen bei den garantierten Größen zu.

Tolérances

Selon les Normes, les tolérances indiquées dans le tableau ci-dessous sont admises sur les tailles garanties.

(A29)

-0.15 (1 - η) P ≤ 50kW	Rendimento	<i>Efficiency</i>	Wirkungsgrad	<i>Rendement</i>
$-(1 - \cos\phi)/6$ min 0.02 max 0.07	Fattore di potenza	<i>Power factor</i>	Leistungsfaktor	<i>Facteur de puissance</i>
±20% *	Scorrimento	<i>Slip</i>	Schlupf	<i>Glissement</i>
+20%	Corrente a rotore bloccato	<i>Locked rotor current</i>	Strom bei blockiertem Läufer	<i>Courant à rotor bloqué</i>
-15% +25%	Coppia a rotore bloccato	<i>Locked rotor torque</i>	Drehmoment bei blockiertem Läufer	<i>Couple à rotor bloqué</i>
-10%	Coppia max	<i>Max. torque</i>	Max. Drehmoment	<i>Couple max</i>

* ± 30% per motori con Pn < 1 kW

** ± 30% for motors with Pn < 1 kW*

* ± 30% für Motoren mit Pn < 1 kW

** ± 30% pour moteurs avec Pn < 1 kW*

M3 - CARATTERISTICHE MECCANICHE

Forme costruttive

I motori serie BN sono previsti nelle forme costruttive indicate in tabella (A30) secondo le Norme CEI EN 60034-14.

Le forme costruttive sono le seguenti:

IM B5 (base)
IM V1, IM V3 (derivate)

IM B14 (base)
IM V18, IM V19 (derivate)

I motori in forma costruttiva IM B5 possono essere installati nelle posizioni IM V1 e IM V3; i motori in forma costruttiva IM B14 possono essere installati nelle posizioni IM V18 e IM V19. In questi casi, sulla targa del motore sarà indicata la forma co-

M3 - MECHANICAL FEATURES

Versions

IEC-normalised BN motors are available in the design versions indicated in table (A30) as per Standards CEI EN 60034-14.

Mounting versions are:

IM B5 (basic)
IM V1, IM V3 (derived)

IM B14 (basic)
IM V18, IM V19 (derived)

IM B5 design motors can be installed in positions IM V1 and IM V3; IM B14 design motors can be installed in positions IM V18 and IM V19. In such cases, the basic design IM B5 or IM B14 is indicated on the motor name plate.

M3 - MECHANISCHE EIGENSCHAFTEN

Bauformen

Die Motoren der Serie BN weisen die in der Abbildung (A30) angegebene Bauform gemäß den Normen CEI EN 60034-14 auf.

Die Bauformen sind:

IM B5 (Grundmodell)
IM V1, IM V3 (Ableitungen)

IM B14 (Grundmodell)
IM V18, IM V19 (Ableitungen)

Die Motoren mit der Bauform IM B5 können mit den Einbaulagen IM V1 und IM V3 eingebaut werden; die Motoren mit der Bauform IM B14 können mit den Einbaulagen IM V18 und IM V19 eingebaut werden. In diesen Fällen ist auf dem Lei-

M3 - CARACTERISTIQUES MECANIKUES

Formes de construction

Les moteurs série BN sont prévus dans les formes de construction indiquées sur le tableau (A30) selon les normes CEI EN 60034-14.

Les formes de construction sont les suivantes:

IM B5 (base)
IM V1, IM V3 (dérivées)

IM B14 (base)
IM V18, IM V19 (dérivées)

Les moteurs en forme de construction IM B5 peuvent être installés dans les positions IM V1 et IM V3; les moteurs en forme de construction IM B14 peuvent être installés dans les positions IM V18 et IM V19. Dans ces cas, la forme de cons-

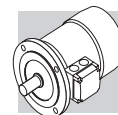

struttiva base IM B5 o IM B14. Nelle forme costruttive dove il motore assume una posizione verticale con albero in basso, si consiglia di richiedere l'esecuzione con tettuccio parapioggia (da prevedere sempre nel caso di motori autofrenanti). Tale esecuzione, pressente nelle opzioni, va richiesta espressamente in fase di ordine in quanto non è prevista nella versione base.

In design versions with a vertically located motor and shaft downwards, it is recommended to request the drip cover (always necessary for brake motors). This facility, included in the option list should be specified when ordering as it does not come as a standard device.

stungsschild des Motors die Bauform IM B5 oder IM B 14 angeben.

Bei Bauformen mit vertikaler Lage des Motors und nach unten gerichteter Welle wird die Ausführung mit Regenschutzabdeckung empfohlen (bei Bremsmotoren stets vorzusehen). Dieses wahlweise Zubehör muß ausdrücklich zum Zeitpunkt der Bestellung verlangt werden, da es bei der Grundausführung nicht vorgesehen ist.

truction base IM B5 ou IM B14 sera indiquée sur la plaque du moteur. Dans les formes de construction où le moteur présente une position verticale avec arbre vers le bas, nous conseillons de demander l'exécution avec capot de protection contre la pluie (à prévoir toujours dans le cas de moteurs freins). Cette exécution, prévue dans les options, doit être expressément demandée en phase de commande étant donné qu'elle n'est pas prévue dans la version de base.

(A30)

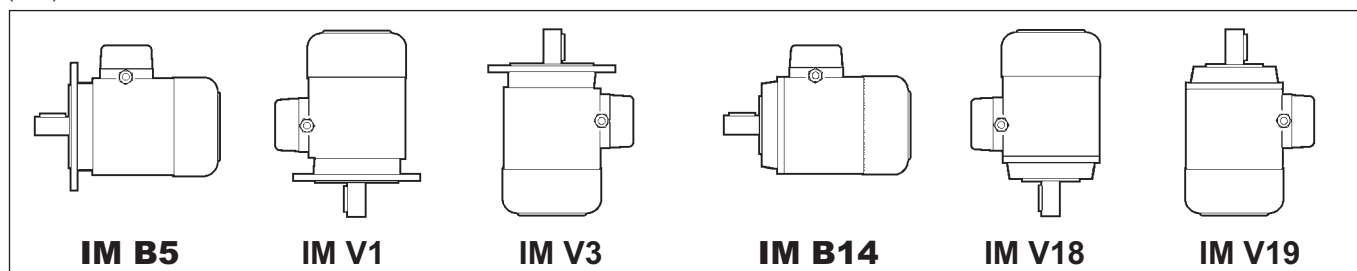

I motori in forma flangiata possono essere forniti con dimensioni di accoppiamento ridotte, come riportato in tabella (A31) - esecuzioni **B5R**, **B14R**.

Flanged motors can be supplied with a reduced mounting interface, as shown in chart (A31) below.

Die Motoren in der Auslegung mit Flansch können mit reduzierten Passmassen gemäß Tabelle (A31) - Versionen **B5R**, **B14R** geliefert werden.

*Les moteurs avec forme à bride peuvent être fournis avec des tailles d'accouplement réduites, comme indiqué dans le tableau (A31) - exécutions **B5R**, **B14R**.*

(A31)

	BN 71	BN 80	BN 90	BN 100	BN 112	BN 132
	DxE - Ø					
B5R ⁽¹⁾	11x23 - 140	14x30 - 160	19x40 - 200	24x50 - 200	24x50 - 200	28x60 - 250
B14R ⁽²⁾	11x23 - 90	14x30 - 105	19x40 - 120	24x50 - 140	—	—

⁽¹⁾ flangia con fori passanti

⁽¹⁾ flange with through holes

⁽¹⁾ Flansch mit durchgehenden Bohrungen

⁽¹⁾ bride avec orifices passants

⁽²⁾ flangia con fori filettati

⁽²⁾ flange with threaded holes

⁽²⁾ Flansch mit Gewindebohrungen

⁽²⁾ bride avec orifices filetés

IP..

Grado di protezione

Degree of protection

Schutzart

Degré de protection

La tabella sottostante riassume la disponibilità dei vari gradi di protezione.

Indipendentemente dal grado di protezione specificato, per installazione all'aperto i motori devono essere protetti dall'irraggiamento diretto e, nel caso d'installazione con albero rivolto verso il basso, è necessario

The following chart provides an overview of the degrees of protection available.

In addition to the degree of protection specified when ordering, motors to be installed outdoors require protection against direct sunlight and also – when they are to be installed vertically down – a drip cover to prevent

In der nachstehenden Tabelle werden die jeweils zur Verfügung stehenden Schutzarten zusammengefasst.

Unabhängig von der spezifischen Schutzart müssen die im Freien installierten Motoren vor direkten Strahlungen geschützt werden. Im Fall einer senkrechten Montage, in der die Welle nach unten

Le tableau ci-dessous résume la disponibilité des différents degrés de protection.

Indépendamment du degré de protection spécifié, en cas d'installation en plein air, les moteurs doivent être protégés des rayons directs du soleil et, en cas d'installation avec l'arbre dirigé vers le bas, il est nécessaire

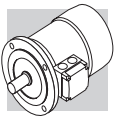

specificare ulteriormente il tettuccio di protezione contro l'ingresso di acqua e corpi solidi (opzione **RC**).

*the ingress of water and solid particles (option **RC**).*

gerichtet ist, sollte darüber hinaus das Schutzdach bestellt werden, das vor dem Eindringen von Wasser und festen Fremdkörpern schützt (Option **RC**).

*de spécifier ultérieurement le capot de protection contre la pénétration de l'eau et des corps solides (option **RC**).*

(A32)

		IP 54	IP 55	IP 56
BN	M		standard	
BN_FD BN_FA	M_FD M_FA	standard		
BN_BA	-		standard	

I motori sono raffreddati mediante ventilazione esterna (IC 411 secondo CEI EN 60034-6) e sono provvisti di ventola radiale in plastica che funziona in entrambi i sensi di rotazione.

L'installazione deve assicurare una distanza minima dalla calotta copriventola alla parete in modo da non avere impedimenti all'ingresso aria e permettere la possibilità di eseguire l'opportuna manutenzione del motore e, se previsto, del freno.

Su richiesta è possibile prevedere una ventilazione forzata indipendente (opzione U1). Questa soluzione consente di aumentare il fattore di utilizzo del motore nel caso di alimentazione da inverter e funzionamento a giri ridotti.

The motors are externally ventilated (IC 411 to CEI EN 60034-6) and are equipped with a plastic fan working in both directions.

The motors must be installed allowing sufficient space between fan cowl and the nearest wall to ensure free air intake and allow access for maintenance purposes on motor and brake, if supplied.

Independent, forced air ventilation (IC 416) can be supplied on request (option U1).

This solution enables to increase the motor duty factor when driven by an inverter and operating at reduced speed.

Die Motoren sind eigenbelüftet (IC 411 gemäß CEI EN 60034-6) und verfügen über ein Radiallüfterrad aus Kunststoff, das in beiden Drehrichtungen arbeiten kann.

Bei der Installation muß sichergestellt werden, daß die Lüfterradabdeckung soweit von der Wand entfernt ist, daß der Lufttritt nicht behindert wird, und daß der Motor und (falls vorhanden) die Bremse problemlos gewartet werden können.

Auf Wunsch können die Motoren mit Fremdbelüftung geliefert werden (Option U1). Diese Lösung ermöglicht das Motorbetriebsfaktor zu erhöhen, wenn vom Frequenzrichter gesteuert und zu niedrigen Geschwindigkeit betrieben.

Les moteurs sont refroidis à l'aide d'une ventilation extérieure (IC 411 selon CEI EN 60034-6) et sont dotés d'un ventilateur à ailettes en plastique qui fonctionne dans les deux sens de rotation.

L'installation doit assurer une distance minimum entre le capot de protection du ventilateur et la paroi afin de permettre une bonne circulation de l'air et rendre plus aisé l'entretien du moteur et si prévu, du frein.

Sur demande, il est possible de prévoir une ventilation forcée indépendante (option U1).

Cette solution permet d'augmenter le facteur d'utilisation du moteur en cas d'alimentation, via un variateur de fréquence, et pour un fonctionnement à faible vitesse.

Senso di rotazione

È possibile il funzionamento in entrambi i sensi di rotazione.

Con collegamento dei morsetti U1,V1,W1 alle fasi di linea L1,L2,L3 si ha rotazione oraria vista dal lato accoppiamento, mentre la marcia antioraria si ottiene scambiando fra loro due fasi.

Direction of rotation

Rotation is possible in both directions. If terminals U1, V1, and W1 are connected to line phases L1, L2 and L3, clockwise rotation (looking from drive end) is obtained. For counterclockwise rotation, switch two phases.

Drehrichtung

Der Betrieb in beiden Drehrichtungen ist möglich.

Schließt man die Klemmen U1, V1, W1 an die Phasen L1, L2, L3 an, dreht sich der Motor im Uhrzeigersinn (von der Verbindungsseite her betrachtet); die Drehung im Gegenuhrzeigersinn erhält man, indem man zwei Phasen vertauscht.

Sens de rotation

Un fonctionnement dans les deux sens de rotation est possible. Avec raccordement des bornes U1, V1, W1 aux phases de ligne L1, L2, L3, on a la rotation dans le sens des aiguilles d'une montre vue du côté liaison alors que le sens inverse s'obtient en intervertissant les deux phases entre elles.

Rumorosità

I valori di rumorosità, rilevati secondo il metodo previsto dalle Norme ISO 1680, sono contenuti entro i livelli massimi previsti dalle Norme CEI EN 60034-9.

Noise

Noise levels, measured using the method prescribed by ISO 1680 Standards, are within the maximum levels specified by Standards CEI EN 60034-9.

Geräuschpegel

Die mit der von der ISO-Norm 1680 vorgesehenen Methoden gemessenen Lärmstärkewerte liegen innerhalb der gemäß den Normen CEI EN 60034-9 zulässigen Höchstgrenzen.

Niveau de bruit

Les valeurs relevées selon la méthode prévue par les normes ISO 1680 sont situées sous les niveaux maximums prévus par les normes CEI EN 60034-9.

Vibrazioni ed equilibratura

Tutti i rotor sono equilibrati con mezza linguetta e rientrano nei limiti di intensità di vibrazione previsti dalle Norme CEI EN 60034-14. Per particolari esigenze di silenzio-

Vibrations and balancing

Rotor shafts are balanced with half key fitted and fall within the vibration class N, as per Standard CEI EN 60034-14. If a further reduced noise level is

Schwingungen und Ausgleich

Alle Rotoren werden durch einen halben Federkeil ausgeglichen und fallen somit unter die, von den Normen CEI EN 60034-14 vorgesehene Schwingungsgradgrenzen.

Vibrations et équilibrage

Tous les rotors sont équilibrés avec une demi languette et rentrent dans les limites d'intensité de vibration prévues par les Normes CEI EN 60034-14.

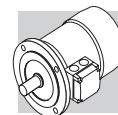

sità potrà essere previsto, a richiesta, un'esecuzione antivibrante in grado ridotto B. La tabella seguente riporta i valori della velocità efficace di vibrazione per equilibratura standard (A) e incrementata (B).

required improved balancing can be optionally requested (class B). Table below shows the value for the vibration velocity for standard (A) and improved (B) balancing.

Bei besonderen Anforderungen an die Laufruhe kann auf Anfrage eine schwingungsdämpfende Ausführung in der reduzierten Klasse (B) geliefert werden. Die folgende Tabelle führt die Werte der Ist-Schwingungsgeschwindigkeit für einen normalen (A) und verbesserten (B) Ausgleich auf.

En cas d'exigences particulière concernant le niveau de bruit, sur demande, il est possible de réaliser une exécution anti-vibrante, de degré réduit (B). Le tableau ci-dessous indique les valeurs de la vitesse efficace de vibration pour un équilibrage standard (A) et améliorée (B).

(A33)

Grado di vibrazione <i>Vibration class</i> Schwingungsklasse <i>Degré de vibration</i>	Velocità di rotazione <i>Angular velocity</i> Drehungsgeschwindigkeit <i>Viitesse de rotation</i>	Limiti della velocità di vibrazione <i>Limits of the vibration velocity</i> Grenzen der Schwingungsgeschwindigkeit <i>Limites de la vitesse de vibration</i> [mm/s]
	n [min ⁻¹]	BN 56 ≤ H ≤ BN 200 M05 ≤ H ≤ M5
A	600 ≤ n ≤ 3600	1.6
B	600 ≤ n ≤ 3600	0.70

I valori si riferiscono a misure con motore liberamente sospeso e funzionamento a vuoto.

Values refer to measures with freely suspended motor in unloaded conditions.

Die Werte beziehen sich auf die Abmessungen mit stehendem Motor, ohne Getriebe und Leerlauf.

Les valeurs se réfèrent à des mesures avec moteur librement suspendu et fonctionnement à vide.

Morsettiera motore

Terminal box

Motorklemmenkasten

Bornier moteur

La morsettiera principale è a sei morsetti per collegamento con capicorda. All'interno della scatola è previsto un morsetto per il conduttore di terra.

Terminal board features 6 studs for eyelet terminal connection. A ground terminal is also supplied for earthing of the equipment.

Die Hauptklemmleiste hat 6 Klemmen für den Anschluß mit Kabelschuhen. Im Innern des Klemmenkastens befindet sich eine Klemme für den Erdleiter.

Le bornier principal prévoit six bornes pour raccordement avec cosses. Dans le boîtier se trouve une borne pour le conducteur de terre.

Le dimensioni dei perni di attacco sono riportate nella tabella seguente.

Terminals number and type are shown in the following table.

Die Abmessungen der Auschüsse sind in der folgenden Tabelle angegeben.

Les dimensions des axes de fixation sont reportées dans le tableau ci-dessous.

Nel caso di motori autofrenanti, il raddrizzatore per l'alimentazione del freno è fissato all'interno della scatola e provvisto di adeguati morsetti di collegamento.

Brakemotors house the a.c./d.c. rectifier (factory pre-wired) inside the terminal box. Wiring instructions are provided either in the box or in the user manual.

Bei den Bremsmotoren befindet sich auch der mit den erforderlichen Anschlußklemmen ausgestattete Gleichrichter für die Stromversorgung der Bremse im Klemmenkasten.



Dans le cas de moteurs freins, le redresseur pour l'alimentation du frein est fixé à l'intérieur du boîtier et est doté de bornes de raccordement.

Eseguire i collegamenti secondo gli schemi riportati all'interno della scatola coprimorsetti o nei manuali d'uso.

Effectuer les connexions selon les schémas indiqués à l'intérieur du bornier, ou dans les manuels d'utilisation.

Die Anschlüsse müssen gemäß den Diagrammen im Klemmkasten oder in den Betriebsanweisungen durchgeführt werden.

(A34)

		N° terminali <i>No. of terminals</i> Klemmen <i>N° bornes</i>	Filettatura terminali <i>Terminal threads</i> Gewinde <i>Filetage bornes</i>	Sezione max del conduttore <i>Wire max cross section area</i> Max. leiterquerschnitt <i>Section max du conducteur</i> mm ²
BN 56...BN 71	M05, M1	6	M4	2.5
BN 80, BN 90	M2	6	M4	2.5
BN 100...BN 112	M3	6	M5	6
BN 132...BN 160MR	M4	6	M5	6
BN 160M...BN 180M	M5	6	M6	16
BN 180L...BN 200L	–	6	M8	25

Ingresso cavi

Cable entry

Kabeleingang

Entrée câbles

Nel rispetto della Norma EN 50262, i fori di ingresso cavi nelle scatole morsettiera presentano filettature metriche della misura indicata nella tabella seguente.



The holes used to bring cables to terminal boxes use metric threads in accordance with standard EN 50262 as indicated in the table here after.

Unter Berücksichtigung der Norm EN 50262 verfügen die Kabeleingänge in die Klemmenkästen über metrische Gewinde, deren Maße, der nachstehenden Tabelle entnommen werden können.

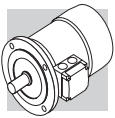
Dans le respect de la Norme EN 50262, les orifices d'entrée câbles dans les boîtes à bornes présentent des filetages métriques de la taille indiquée dans le tableau ci-dessous.



(A35)

		Ingresso cavi / Cable entry kabeldurchführung / Entrée câbles	Diametro max. cavo allacciabile / Max. cable diameter allowed Max. zulässiger Kabeldurchmesser / Diam. maxi câble
			[mm]
BN 63	M05	2 x M20 x 1.5	13
BN 71	M1	2 x M25 x 1.5	17
BN 80 - BN 90	M2	2 x M25 x 1.5	17
BN 100	M3	2 x M32 x 1.5	21
		2 x M25 x 1.5	17
BN 112	—	2 x M32 x 1.5 4 x M25 x 1.5	17
BN 132...BN 160MR	M4	4 x M32 x 1.5	21
BN 160M...BN 200L	M5	2 x M40 x 1.5	29

Cuscinetti

I cuscinetti previsti sono del tipo radiale a sfere con lubrificazione permanente precaricati assialmente.

I tipi utilizzati sono indicati nelle tabelle seguenti. La durata nominale a fatica L_{10h} dei cuscinetti, in assenza di carichi esterni applicati è superiore a 40.000 ore, calcolata secondo ISO 281.

DE = lato comando

NDE = lato opposto comando

Bearings

Life lubricated preloaded radial ball bearings are used, types are shown in the chart here under. Calculated endurance lifetime L_{10h} , as per ISO 281, in unloaded condition, exceeds 40000 hrs.

DE = drive end

NDE = non drive end

Lager

Bei den Lagern handelt es sich um Radialkugellager mit Dauerschmierung.

Die verwendeten Typen sind in den folgenden Tabellen angegeben.

Die Lebensdauer der Lager bei einer Beanspruchung L_{10h} ist, sofern keine externen Kräfte wirken, über 40.000 Stunden (Berechnung gemäß ISO 281).

DE = Wellenseite

NDE = Lüfterseite

Roulements

Les roulements prévus sont du type radial à billes avec lubrification permanente.

Les types utilisés sont indiqués dans les tableaux ci-dessous.

La résistance à la déformation L_{10h} des roulements en absence de charges extérieures appliquées est supérieure à 40.000 heures calculée selon ISO 281.

DE = sortie arbre

NDE = côté ventilateur

(A36)

	DE	NDE	
	M, M_FD, M_FA	M	M_FD; M_FA
M05	6004 2Z C3	6201 2Z C3	6201 2RS C3
M1	6004 2Z C3	6202 2Z C3	6202 2RS C3
M2	6007 2Z C3	6204 2Z C3	6204 2RS C3
M3	6207 2Z C3	6206 2Z C3	6206 2RS C3
M4	6309 2Z C3	6308 2Z C3	6308 2RS C3
M5	6309 2Z C3	6309 2Z C3	6309 2RS C3

(A37)

	DE	NDE	
	BN, BN_FD, BN_FA, BN_BA	BN, BN_BA	BN_FD; BN_FA
BN 56	6201 2Z C3	6201 2Z C3	—
BN 63	6201 2Z C3	6201 2Z C3	6201 2RS C3
BN 71	6202 2Z C3	6202 2Z C3	6202 2RS C3
BN 80	6204 2Z C3	6204 2Z C3	6204 2RS C3
BN 90	6205 2Z C3	6205 2Z C3	6305 2RS C3
BN 100	6206 2Z C3	6206 2Z C3	6206 2RS C3
BN 112	6306 2Z C3	6306 2Z C3	6306 2RS C3
BN 132	6308 2Z C3	6308 2Z C3	6308 2RS C3
BN 160MR	6309 2Z C3	6308 2Z C3	6308 2RS C3
BN 160M/L	6309 2Z C3	6309 2Z C3	6309 2RS C3
BN 180M	6310 2Z C3	6309 2Z C3	6309 2RS C3
BN 180L	6310 2Z C3	6310 2Z C3	6310 2RS C3
BN 200L	6312 2Z C3	6310 2Z C3	6310 2RS C3

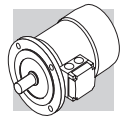

M4 - CARATTERISTICHE ELETTRICHE

Tensione

I motori a una velocità sono previsti nell'esecuzione normale per tensione nominale 230V Δ / 400V Y, 50 Hz con tolleranza di tensione ± 10% (escluso i tipi M3LC4 e M3LC6).

In targa sono indicati oltre alla tensione nominale i campi di funzionamento consentiti, p.e.:

220 - 240V Δ
280 - 415V Y /50 Hz.

In accordo alle Norme CEI EN 60034-1 i motori possono funzionare alle tensioni sopra indicate con tolleranza del ± 5%.

Per funzionamento ai limiti di tolleranza la temperatura può superare di 10 K il limite previsto dalla classe di isolamento adottata.

Ad eccezione dei motori autofrenanti tipo BN_FD in targa vengono indicati anche i valori corrispondenti al funzionamento a 60 Hz (p.e. 460Y, 60 Hz) ed il relativo campo di tensione:

440 - 480VY, 60 Hz.

Per i motori autofrenanti con freno tipo FD le tensioni standard sono:

220V - 240V Δ - 50 Hz
380V - 415V Y - 50 Hz

con tensione di alimentazione freno 230V ± 10%.

La tabella seguente riporta le tensioni previste per i motori.

M4 - ELECTRICAL CHARACTERISTICS

Voltage

Single speed motors are rated for 230/400 V - 50 Hz.

A tolerance of ±10% applies to nominal voltage, with the exception of motors type M3LC4 and M3LC6.

In addition to nominal voltage-frequency values the name plate also shows voltage ranges the motor can operate under, e.g.:

220-240V Δ - 50 Hz
380-415V Y - 50 Hz

As per Norms CEI EN 60034-1 on above voltage values the ±5% tolerance applies.

When operating close to the tolerance limit values the winding temperature can exceed by 10 K the rated temperature for the given insulation class.

With the exception of BN_FD brakemotors, the rated voltage values for operation under 60 Hz mains are also shown on the nameplate, e.g. 460Y-60 Hz along with related tolerance field, e.g. 440-480V Y-60 Hz.

For brakemotors, FD type, rated voltage is:

220-240V Δ - 50 Hz
380-415V Y - 50 Hz

Brake supply is a.c. 230V ±10% single phase.

Chart below shows standard and optional wiring of motors.

M4 - ELEKTRISCHE EIGENSCHAFTEN

Spannung

Die eintourigen Motoren müssen in der Standardausführung mit einer Spannung von 230 V Δ / 400 V Y, 50 Hz mit einer Toleranz von ± 10% gespeist werden (Type M3LC4 und M3LC6 ausgenommen).

Auf dem Schild werden die Nennspannung hinaus, auch die zulässigen Ansprechbereiche angegeben, z.B.:

220-240V Δ
380-415V Y/50 Hz.

Gemäß den Normen CEI EN 60034-1 können die Motoren auf die oben genannten Spannungen mit Toleranzen von ± 5% arbeiten.

Bei Betrieb an den Spannungsgrenzen, kann die Temperatur bis zum 10K die für die verwendeten Isolierstoffklasse angegebenen Grenze überschreiten.

Darüber hinaus wird auf den Typenschild die dem 60 Hz-Betrieb entsprechenden Werte angegeben (d.h. 460 Y, 60 Hz) und das entsprechende Spannungsfeld, 440-480VY, 60 Hz.

Für die selbstbremsenden Motoren mit dem Bremstyp FD sind die Standardspannungen folgende:

220V - 240V Δ - 50 Hz
380V - 415V Y - 50 Hz

mit Bremsspannungsversorgung von 230V ± 10%.

Die folgende Tabelle für die für die Motoren vorgesehenen Spannungen auf.

M4 - CARACTERISTIQUES ELECTRIQUES

Tension

Les moteurs à polarité unique sont prévus dans l'exécution normale pour tension 230V Δ / 400V Y, 50 Hz avec tolérance de tension ± 10% (sauf les types M3LC4 et M3LC6).

Outre la tension nominale, les plages de fonctionnement permises sont indiquées sur la plaquette signalétique, à savoir:

220-240V Δ
380-415V Y/50 Hz.

Selon les normes CEI EN 60034-1 les moteurs peuvent fonctionner aux tension indiquées ci-dessus avec une tolérance de ± 5%.

Pour un fonctionnement à la limite de tolérance, la température peut dépasser les 10K, la limite prévue de la classe d'isolation choisie.

Sur la plaque marque sont de plus indiqués les valeurs correspondantes au fonctionnement en 60 Hz (ex.460Y, 60 Hz) et la relative plage de tension: 440 - 480VY, 60 Hz.

En ce qui concerne les moteurs autofrenants avec frein de type FD, les tensions standard sont les suivantes :

220V - 240V Δ - 50 Hz
380V - 415V Y - 50 Hz

avec tension d'alimentation du frein 230V ± 10%.

La tableau ci-dessous indique les tensions prévues pour les moteurs.

(A38)

		BN M	BN_FD M_FD			BN_FA / BN_BA M_FA		Esecuzione Configuration Version Execution
			V _{mot} ± 10 % 3~	V _{mot} ± 10 % 3~	V _B ± 10 % 1~	V _{mot} ± 10 % 3~	V _B ± 10 % 3~	
BN 56 - BN 132	M05...M4	230/400 - 50Hz 460 - 60Hz	230/400V Δ/Y - 50 Hz	230V	230/400V Δ/Y - 50 Hz 460V Y - 60Hz	230/400V Δ/Y - 50 Hz 460V Y - 60Hz	Standard	
BN 100 - BN 132	M3 - M4	400/690 - 50Hz 460 - 60Hz	400/690V Δ/Y - 50 Hz	400V	400/690V Δ/Y - 50 Hz 460V Y - 60Hz	400/690V Δ/Y - 50 Hz 460V Y - 60Hz	A richiesta, senza sovrapprezzo On request at no extra charge Auf Anfrage, ohne Aufpreis Sur demande, sans majoration de prix	

I motori a due velocità 400V/50Hz, sono previsti per tensione nominale standard 400V; tolleranze applicabili secondo CEI EN 60034-1.

Nella tabella seguente sono indicati i vari tipi di collegamenti previsti per i motori in funzione della polarità.

The only rated voltage for motors type 400V/50Hz and all double speed motors is 400V. Applicable tolerances as per CEI EN 60034-1.

The table below shows the wiring options available.

Alle polumschaltbaren Motoren, die Typen 400V/50Hz, sind nicht umschaltbar, standard-mäßig nur für ein Spannung 400V vorgesehen; geltenden Toleranzen gemäß CEI EN 60034-1.

Auf die folgende Tabelle werden die verschiedenen für die Motoren vorgesehenen Anschlußtypen angegeben.

Tous les moteur à deux vitesses, les types 400V/50Hz, sont prévus pour une tension nominale standard de 400V; tolérances applicables selon CEI EN 60034-1.

Dans le tableau ci-dessous sont indiqués les différents types de connexion prévus pour les moteurs.

(A39)

		Poli / Pole / Polig / Pôles	Collegamento avvolgimento / Wiring options Wicklungsanschluß / Connexion du bobinage
		BN 56...BN 200	M05...M5

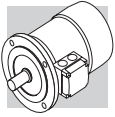

Frequenza

I motori ad una velocità nell'esecuzione standard riportano in targa oltre alle tensioni del funzionamento a 50 Hz il campo di tensione 440 - 480V 60 Hz (escluso motori autofrenanti con freno FD) con potenza aumentata di circa il 20%

La potenza di targa dei motori a 60Hz corrisponde a quanto riportato nella tabella (A40) seguente:

Frequency

With the exception of brakemotors, name plate of standard single speed motors shows, besides the 50 Hz voltage ratings, also the rated power output for 60 Hz operation in the 440-480 V range.

Power output is increased by approx 20%.

Rated output power for 60 Hz operation is shown in the following diagram.

Frequenz

Bei eintourigen Motoren in der Standardausführung wird außer den 50 Hz-Betriebsspannungen auch den Spannungsfeld 440 - 480V 60 Hz angegeben (mit Ausnahme von Bremsmotoren mit Bremsentyp FD) mit einer erhöhten Leistung von ungefähr 20%.



Die Leistung auf das Namensschild von 60 Hz-Motoren entspricht den Daten aus der folgenden Tabelle (A40):

Fréquence

Les moteurs à une vitesse en exécution standard reportent sur la plaque marque en plus des tension du fonctionnement à 50 Hz la plage de tension 440 - 480V 60 Hz (moteurs freins avec frein FD exclus) avec puissance augmentée de 20% env.

La puissance sur la plaque marque des moteurs à 60 Hz correspond à celle indiquée au tableau (A40) suivant :

(A40)

		2P	4P	6P
		P _n [kW]		
BN 56A	–	–	0.06	–
BN 56B	M0B	–	0.10	–
BN 63A	M05A	0.21	0.14	0.10
BN 63B	M05B	0.30	0.21	0.14
BN 71A	M05C	0.45	0.30	0.21
BN 71B	M1SD	0.65	0.45	0.30
BN 80A	M1LA	0.90	0.65	0.45
BN 80B	M2SA	1.30	0.90	0.65
BN 90S	M2SB	–	1.30	0.90
BN 90SA	M2SB	1.8	–	–
BN 90L	M3SA	2.5	–	1.3
BN 90LA	M3SA	–	1.8	–
BN 100L	M3LA	3.5	–	–
BN 100LA	M3LA	–	2.5	1.8
BN 100LB	M3LB	4.7	3.5	2.2
BN 112M	M3LB	4.7	4.7	2.5
	M3LC	–	4.7	2.5
BN 132S	M4SA	–	6.5	3.5
BN 132SA	M4SA	6.3	–	–
BN 132SB	M4SB	8.7	–	–
BN 132M	M4LA	11	–	–
BN 132MA	M4LA	–	8.7	4.6
BN 132MB	M4LB	–	11	6.5
BN 160MR	M4LC	12.5	12.5	–
BN 160MB	M5SB	17.5	–	–
BN 160M	M5SA	–	–	8.6
BN 160L	M5S	21.5	17.5	12.6
BN 180M	M5LA	24.5	21.5	–
BN 180L	–	–	25.3	17.5
BN 200L	–	34	34	22

Motori a doppia polarità alimentati a 60 Hz avranno un aumento della potenza nominale, riferita a 50 Hz, pari al 15%.

Qualora sulla targhetta di un motore destinato ad essere alimentato a 60 Hz sia richiesto un valore di potenza nominale pari a quello normalizzato a 50 Hz specificare in designazione l'opzione PN.

For two-speed motors operated under 60 Hz supply the rated power output is increased by 15% as compared to same motor with 50 Hz supply.

If same IEC-normalised 50 Hz power rating value is desired on name plate of a 60 Hz operated motor specify option PN in the ordering code.

Standard motors wound for 50

Für polumschaltbare Motoren mit 60 Hz Spannungsversorgung ist die vorgesehene Leistungserhöhung gemäß den Datenblätter von 15%.

Wenn die angefragte 60 Hz-Leistung der normierten 50 Hz-Leistung entspricht, geben bei der Bezeichnung das Option PN an. Die Motoren mit einer Wicklung für eine Frequenz von 50 Hz

Pour les moteurs à deux vitesses avec alimentation 60 Hz l'augmentation de puissance prévue per rapport aux valeurs indiquées dans les tableaux techniques, sera de 15%.

Si la puissance requise à 60 Hz correspond à la puissance normalisée à 50 Hz on devra indiquer l'option PN.

Les moteurs bobinés pour fré-

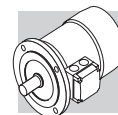

I motori normalmente avvolti per frequenza 50 Hz possono essere usati in reti a 60 Hz con i loro dati che saranno corretti come da tabella seguente.
I freni, se presenti, dovranno sempre essere alimentati alla tensione V_b , riportata in targa.

Hz supply can be operated under 60 Hz with main data corrected as per chart below: Brakes, if fitted, must be supplied with the voltage value V_b that is stated on the nameplate.

können entsprechend den Angaben von Tabelle (A41) an Netze mit 60 Hz angeschlossen werden.
Die Bremse muss, falls angebaut, mit der auf dem Typenschild angegebenen Spannung V_b betrieben werden.

quence 50 Hz peuvent être utilisés sur réseau à 60 Hz selon les indications du tableau (A41). Les freins, si présents, devront toujours être alimentés avec la tension V_b rapportée sur la plaque.

(A41)

50 Hz	60 Hz			
V - 50 Hz	V - 60 Hz	P _n - 60 Hz	M _n , M _a /M _n - 60 Hz	n [min ⁻¹] - 60 Hz
230/400 Δ/Y	220 - 240 Δ 380 - 415 Y	1	0.83	1.2
400/690 Δ/Y	380 - 415 Δ			
230/400 Δ/Y	265 - 280 Δ 440 - 480 Y	1.15	1	1.2
400/690 Δ/Y	440 - 480 Δ			

Potenza nominale

Le tabelle dei dati tecnici del catalogo riportano le caratteristiche funzionali a 50 Hz in condizioni ambientali standard secondo le Norme CEI EN 60034-1 (temperatura 40 °C e altitudine <1000 m s.l.m.).
I motori possono essere impiegati a temperature comprese tra 40 °C e 60 °C applicando i declassamenti di potenza indicati nelle tabelle seguenti.

Rated power

Catalogue rating values are calculated for 50 Hz operation and for standard ambient conditions (temperature 40 °C; elevation <1000 m a.s.l.) as per the CEI EN 60034-1 Standards. The motors can be used within the 40 - 60 °C temperature range with rated power output adjusted by factors given in the following charts.

Nennleistung

Die Betriebsdatentabellen des Katalogs enthalten die technischen Daten bei einer Frequenz von 50 Hz bei normalen Umgebungsbedingungen gemäß den Normen CEI EN 60034-1 (Temperatur 40°C und Höhe <1000 m ü.d.M.). Die Motoren können in größeren Temperaturen zwischen 40°C und 60°C betrieben werden, wenn man die in den Tabellen (A41) angegebenen Rückstufungen anwendet.

Puissance nominale

Les tableaux fonctionnels du catalogue présentent les caractéristiques techniques à 50 Hz dans des conditions ambiantes standard selon les normes CEI EN 60034-1 (température 40°C et altitude <1000 m). Les moteurs peuvent être employés à des températures comprises entre 40°C et 60°C en appliquant les déclassements de puissance indiqués dans les tableaux suivantes.

(A42)

Temperatura ambiente / Ambient temperature / Umgebungstemperatur / Température ambiante(°C)	40°	45°	50°	55°	60°
Potenza ammissibile in % della potenza nominale / Permitted power as a % of rated power Zulässige Leistung in % der Nennleistung / Puissance admissible en % de la puissance nominale	100%	95%	90%	85%	80%

Quando è richiesto un declassamento del motore superiore al 15%, contattare il ns. Servizio Tecnico.

Should a derating factor higher than 15% apply please consult factory.

Wenn eine Motordeklassierung höher als 15% gefragt ist, wir bitten um Rückfrage.

Si un déclassement du moteur supérieur à 15% est requis, on devra contacter notre Service Technique.

Classe d'isolamento

Insulation class

Isolationsklasse

Classes d'isolation

CL F

I motori di produzione Bonfiglioli impiegano, di serie, materiali isolanti (filo smaltato, isolanti, resine d'impregnazione) in classe F.

Bonfiglioli motors use class F insulating materials (enamelled wire, insulators, impregnation resins) as compare to the standard motor.

Die Motoren von Bonfiglioli sind serienmäßig mit Isolierstoffen (Emaildraht, Isolierstoffen, Imprägnierharzen) der Klasse F ausgestattet.

De série, les moteurs fabriqués par Bonfiglioli utilisent des matériaux isolants (fil émaillé, isolants, résines d'impregnation) en classe F.

CL H

Su richiesta può venire specificata la classe di isolamento H.
In genere, per i motori in esecuzione standard la sovratemperatura dell'avvolgimento statore è contenuta entro il limite di 80 K, corrispondente alla sovratemperatura di classe B.

Motors manufactured in insulation class H are available at request. In standard motors, stator windings over temperature normally stays below the 80 K limit corresponding to class B over temperature.

Auf Anfrage können sie auch in der Klasse H geliefert werden.
Allgemein hält sich die Übertemperatur der Motoren in der Standardausführung innerhalb des Grenzwerts von 80 K, der einer Übertemperatur der Klasse B entspricht.

Sur demande, la classe d'isolation H peut être spécifiée. En général, pour les moteurs en exécution standard, l'échauffement de l'enroulement du stator se situe dans la limite de 80 K, correspondant à un échauffement de classe B.

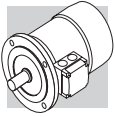

L'accurata scelta dei componenti del sistema isolante consente l'impiego dei motori anche in climi tropicali ed in presenza di vibrazioni normali.

Per applicazioni in presenza di sostanze chimiche aggressive, o di elevata umidità, è consigliabile contattare il Servizio Tecnico Bonfiglioli per la selezione del prodotto più idoneo.

A careful selection of insulating components makes the motors compatible with tropical climates and normal vibration.

For applications involving the presence of aggressive chemicals or high humidity, contact Bonfiglioli Engineering for assistance with product selection.

Die sorgfältig Wahl der Komponenten des Isoliersystem gestatten den Einsatz dieser Motoren auch unter tropischen Klimabedingungen und bei Vorliegen normaler Schwingungen.

Für den Einsatz in in der Nähe aggressiv wirkenden chemischen Substanzen oder bei hoher Luftfeuchtigkeit, wird empfohlen sich zur Wahl eines passenden Produktes mit unserem Technischen Kundendienst in Verbindung zu setzen.

Le choix soigné des composants du système d'isolation permet d'utiliser également les moteurs dans des climats tropicaux et en présence de vibrations normales.

Pour des applications en présence de substances chimiques agressives, ou d'humidité élevée, il est conseillé de contacter le Service Technique Bonfiglioli pour sélectionner le produit le plus adapté.

(A43)

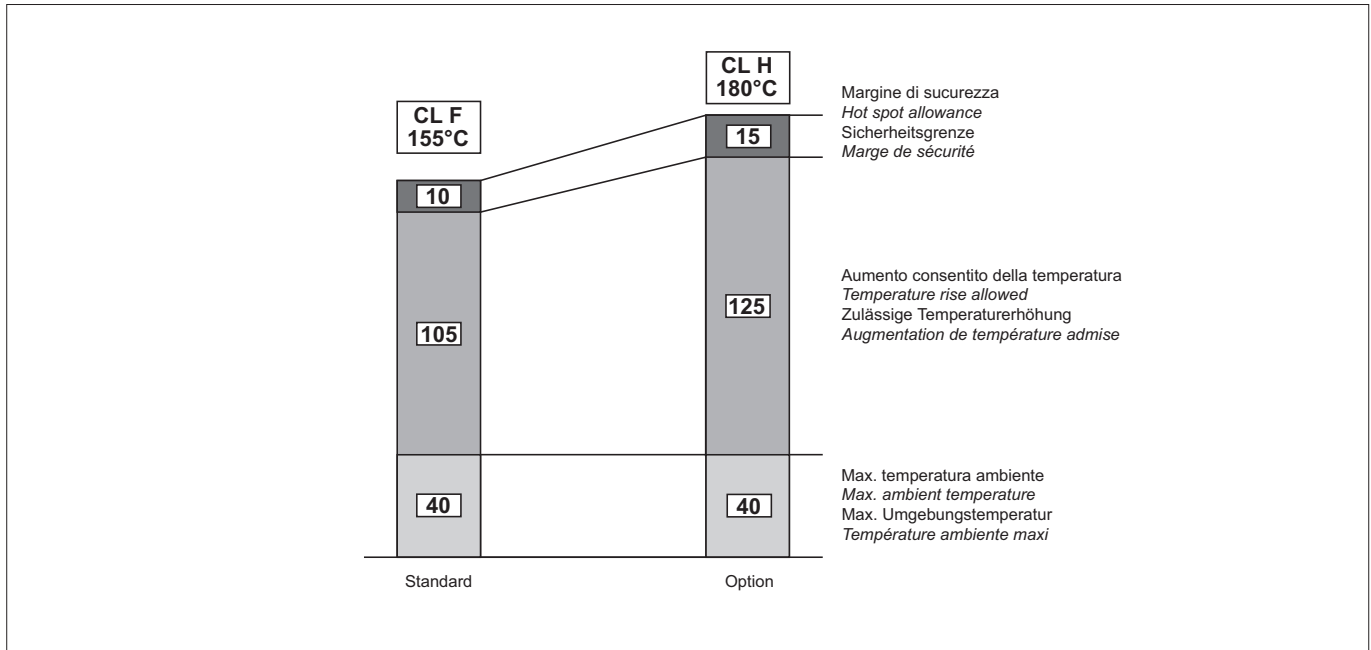

Tipo di servizio

Se non indicato diversamente la potenza dei motori riportata a catalogo si riferisce al servizio continuo S1.

Per i motori utilizzati in condizioni diverse da S1 sarà necessario identificare il tipo di servizio previsto con riferimento alle Norme CEI EN 60034-1.

In particolare, per i servizi S2 ed S3, è possibile ottenere una maggiorazione della potenza termica rispetto a quella prevista per il servizio continuo secondo quanto indicato nella tabella (A44) valida per motori ad una velocità. Per motori a doppia polarità interpellare il nostro Servizio Tecnico.

Type of duty

Unless otherwise indicated, the power of motors specified in the catalogue refers to continuous duty S1.

For motors used under conditions other than S1, the type of duty required must be adjusted with reference to CEI EN 60034-1 Standards.

In particular, for duties S2 and S3, power can be adjusted with respect to continuous duty according to data in table (A44) applicable to single speed motors. For double speed motors, contact our Technical Service.

Betriebsart

Sofern nicht anders angegeben, bezieht sich die im Katalog angegebene Motorleistung auf den Dauerbetrieb S1.

Bei den Motoren, die für eine andere Betriebsart als S1 vorgesehen sind, muß man die Betriebsart unter Bezugnahme auf die Normen CEI EN 60034-1 identifizieren.

Insbesondere kann man für die Betriebsarten S2 und S3 nach der für Motoren mit einer Drehzahl. Gültigen Tabelle (A44) eine Überdimensionierung der Leistung für den Dauerbetrieb im Vergleich zur vorgesehenen Betriebsart erreichen. Für polumschaltbaren Motoren, bitte Rückfrage.

Type de service

sauf indication contraire, la puissance des moteurs reportée dans le catalogue se réfère au service continu S1.

Pour les moteurs utilisés dans des conditions différentes de S1, il sera nécessaire d'identifier le type de service prévu en se référant aux normes CEI EN 60034-1.

En particulier, pour les services S2 et S3, il est possible d'obtenir une majoration de la puissance par rapport à celle prévue pour le service continu selon ce qui est indiqué dans le tableau (A44) valable pour les moteurs à une vitesse. Pour les moteurs à double polarité, contacter notre Service Technique.

(A44)

	Servizio / Duty / Betriebsart / Service						
	S2			S3 *			S4 - S9
	Durata del ciclo (min) / Cycle duration (min) Zyklusdauer (min) / Durée du cycle (min)			Rapporto di intermittenza (I) / Cyclic duration factor (I) Relative Einschaltdauer (I) / Rapport d'intermittence (I)			Interpellarci Consult factory Rückfrage Nous contacter
	10	30	60	25%	40%	60%	
f _m	1.35	1.15	1.05	1.25	1.15	1.1	

* La durata del ciclo dovrà comunque essere uguale o inferiore a 10 minuti; se superiore interpellare il nostro Servizio Tecnico.

* Cycle duration must, in any event, be equal to or less than 10 minutes; if this time is exceeded, please contact our Technical Service.

* Die Zyklusdauer muß in jedem Fall kleiner oder gleich 10 Minuten sein. Wenn sie darüber liegt, unseren Technischen Kundendienst zu Rate ziehen.

* La durée du cycle devra être inférieure ou égale à 10 minutes. Si supérieure, contacter notre Service Technique.

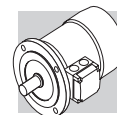

Rapporto di intermittenza:

Cyclic duration factor:

Relative Einschaltdauer:

Rapport d'intermittence:

$$I = \frac{t_f}{t_f + t_r} \cdot 100$$

(23)

t_f = tempo di funzionamento a carico costante
 t_r = tempo di riposo

t_f = work time under constant load
 t_r = rest time

t_f = Betriebszeit mit konstanter Last
 t_r = Aussetzzeit

t_f = temps de fonctionnement à charge constante
 t_r = temps de repos

Servizio di durata limitata S2

Limited duration duty S2

Kurzzeitbetrieb S2

Service de durée limitée S2

Caratterizzato da un funzionamento a carico costante per un periodo di tempo limitato, inferiore a quello richiesto per raggiungere l'equilibrio termico, seguito da un periodo di riposo di durata sufficiente a ristabilire, nel motore, la temperatura ambiente.

This type of duty is characterized by operation at constant load for a limited time, which is shorter than the time required to reach thermal equilibrium, followed by a rest period of sufficient duration to restore ambient temperature in the motor.

Betrieb mit konstanter Last für eine begrenzte Zeit, die unter der Zeit liegt, die zum Erreichen des thermischen Gleichgewichts benötigt wird, gefolgt von einer Aussetzzeit, die so lang ist, daß der Motor wieder auf die Umgebungstemperatur abkühlen kann.

Caractérisé par un fonctionnement à charge constante pour une période de temps limitée, inférieure à celle nécessaire pour atteindre l'équilibre thermique, suivie par une période de repos de durée suffisante pour rétablir, dans le moteur, la température ambiante.

Servizio intermittente periodico S3:

Periodical intermittent duty S3:

Periodische Einschaltdauer S3:

Service intermittent périodique S3

Caratterizzato da una sequenza di cicli di funzionamento identici, ciascuno comprendente un periodo di funzionamento a carico costante ed un periodo di riposo. In questo servizio, la corrente di avviamento non influenza la sovratemperatura in modo significativo.

This type of duty is characterized by a sequence of identical operation cycles, each including a constant load operation period and a rest period. For this type of duty, the starting current does not significantly influence overtemperature.

Betrieb mit aufeinanderfolgenden identischen Betriebszyklen, die alle einen kurzzeitigen Betrieb mit konstanter Belastung und eine Aussetzzeit einschließen. Bei dieser Betriebsart beeinflusst der Anlaufstrom die Übertemperatur nicht in signifikanter Weise.

Caractérisé par une séquence de cycles de fonctionnement identiques, comprenant chacun une période de fonctionnement à charge constante et une période de repos. Dans ce service, le courant de démarrage n'influence pas l'excès de température de façon significative.

Funzionamento con alimentazione da inverter

Inverter-controlled motors

Betrieb mit Versorgung über Inverter

Fonctionnement avec alimentation par variateur de vitesse

I motori elettrici della serie BN ed M possono essere utilizzati con alimentazione da inverter PWM, e tensione nominale all'ingresso del convertitore fino a 500 V.

The electric motors of series BN and M may be used in combination with PWM inverters with rated voltage at transformer input up to 500 V. Standard motors use a phase insulating system with separators, class 2 enamelled wire and class H impregnation resins (1600V peak-to-peak voltage pulse capacity and rise edge $t_s > 0.1\mu s$ at motor terminals). Table (A54) shows the typical torque/speed curves referred to S1 duty for motors with base frequency $f_b = 50$ Hz.

Die Elektromotoren der Serie BN und M können über einen Inverter PWM und mit einer Nennspannung am Wandlereingang bis zu 500 V versorgt werden. Das an den Serienmotoren angewendete System sieht eine Phasenisolierung mittels Trennvorrichtungen vor, ebenso wie einen Emailldraht mit Grad 2 und Imprägnierungsharze in der Klasse H vor (Abdichtungsgrenze bei Spannungsimpuls 1600V Spitze-Spitze und Anstiegsfront $t_s > 0.1\mu s$ an den Motorklemmen). Die typischen Merkmale von Drehmoment/Geschwindigkeit im Betrieb S1 für Motoren mit einer Grundfrequenz $f_b = 50$ Hz werden in der Tab. (A54) angegeben. Bei Betriebsfrequenzen unter ungefähr 30 Hz müssen die selbstlüftenden Standardmotoren (IC411) aufgrund der in diesem Fall abnehmenden Belüftung entsprechend paarweise deklassiert, oder in Alternative, mit unabhängigen Servoventilatoren ausgestattet werden. Bei über der Grundfrequenz liegenden Frequenzen arbeitet der Motor,

Les moteurs électriques de la série BN et M peuvent être utilisés avec alimentation par variateur PWM, et tension nominale en entrée du convertisseur jusqu'à 500V. Le système adopté sur les moteurs de série prévoit l'isolation de phase avec des séparateurs, l'utilisation de fil émaillé niveau 2 et résines d'imprégnation de classe H (limite de maintien à l'impulsion de tension 1600V pic-pic et front de montée $t_s > 0.1\mu s$ aux bornes moteur). Les caractéristiques typiques couple/vitesse en service S1 pour moteur avec fréquence de base $f_b = 50$ Hz sont indiquées dans le tab. (A54).

Il sistema isolante sui motori di serie prevede l'isolamento di fase con separatori, l'utilizzo di filo smaltato in grado 2 e resine d'imprégnazione in classe H (limite di tenuta all'impulso di tensione 1600V picco-picco e fronte di salita $t_s > 0.1\mu s$ ai morsetti motore). Le caratteristiche tipiche coppia/velocità in servizio S1 per motore con frequenza base $f_b = 50$ Hz sono riportate in tab. (A54). Per frequenze di funzionamento inferiori a circa 30 Hz, a causa della diminuzione della ventilazione, i motori standard autoventilati (IC411) devono essere opportunamente declassati in coppia o, in alternativa, devono essere provvisti di servoventilatore indipendente.

Because ventilation is somewhat impaired in operation at lower frequencies (about 30 Hz), standard motors with incorporated fan (IC411) require adequate torque derating or - alternately - the addition of a separate supply fan cooling. Above base frequency, upon reaching the maximum output voltage of the inverter, the motor enters a steady-power field of operation, and shaft torque drops with ratio (f/f_b) .

Pour des fréquences de fonctionnement inférieures à environ 30 Hz, à cause de la diminution de la ventilation, les moteurs standards autoventilés (IC411) doivent être opportunément déclassés au niveau du couple ou, en alternative, doivent être équipés de servoventilateur indépendant. Pour des fréquences supérieures à la fréquence de base, une fois

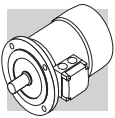

campo di funzionamento a potenza costante, con coppia all'albero che si riduce ca. con il rapporto (f/f_b) . Poiché la coppia massima del motore decresce ca. con $(f/f_b)^2$, il margine di sovraccarico ammesso dovrà essere progressivamente ridotto.

As motor maximum torque decreases with $(f/f_b)^2$, the allowed overloading must be reduced progressively.

nach Erreichen des max. Spannungswerts am Inverterausgang in einem Betriebsbereich unter konstanter Leistung mit einem Drehmoment an der Welle, der sich ungefähr im Verhältnis (f/f_b) reduziert. Da das max. Drehmoment des Motors mit ungefähr $(f/f_b)^2$ abnimmt, muss auch der zulässige Überbelastungsgrenzwert progressiv reduziert werden.

la valeur maximale de tension de sortie du variateur atteinte, le moteur fonctionne dans une plage de fonctionnement à puissance constante, avec couple à l'arbre qui se réduit avec le rapport (f/f_b) . Dans la mesure où le couple maximal du moteur diminue avec $(f/f_b)^2$, la marge de surcharge admise doit être progressivement réduite.

(A45)

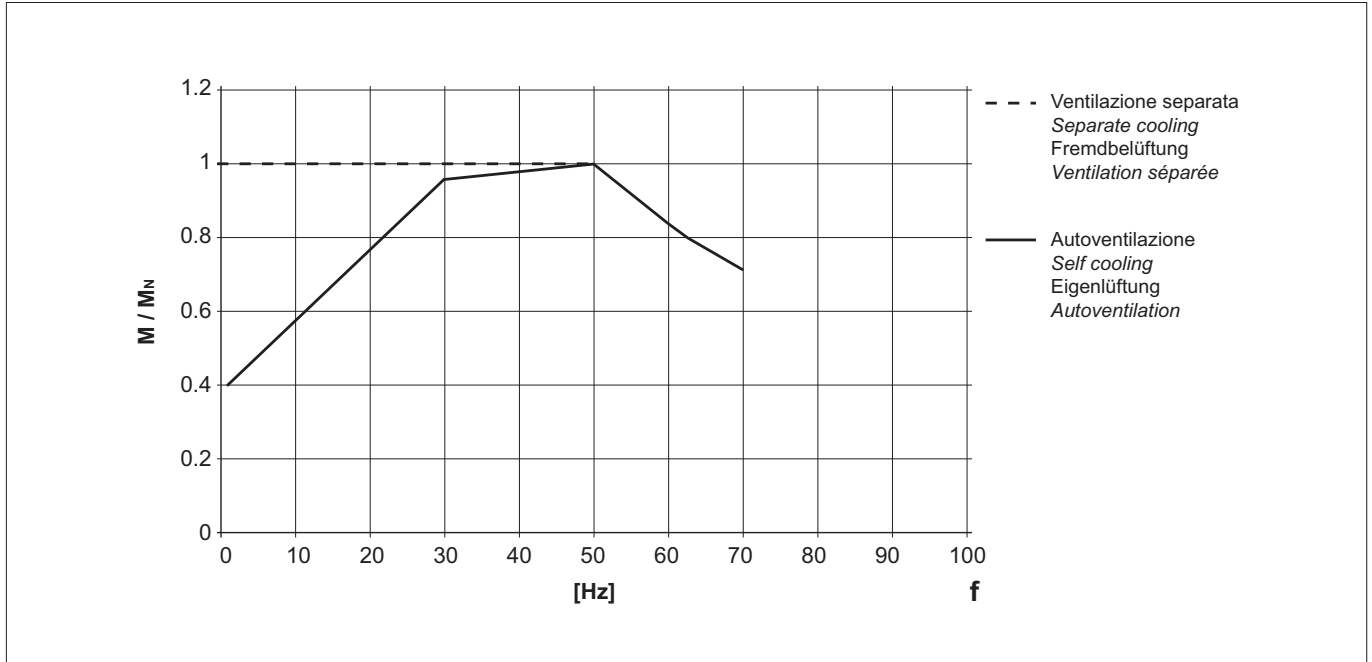



Per funzionamento oltre la frequenza nominale, la velocità limite meccanica dei motori è riportata in tabella (A46):

Table (A46) reports the mechanical limit speed for motor operation above rated frequency:

Für einen Betrieb, der über die Nennfrequenz hinausgeht, wird die Geschwindigkeitsbegrenzung der Motoren in der Tabelle (A46) angegeben:

En cas de fonctionnement au-delà de la fréquence nominale, la vitesse limite mécanique des moteurs est indiquée dans le tableau (A46):

(A46)

		n [min ⁻¹]		
		2p	4p	6p
 ≤ BN 112	 M05...M3	5200	4000	3000
BN 132...BN 200L	M4, M5	4500	4000	3000

A velocità superiori alla nominale i motori presentano maggiori vibrazioni meccaniche e rumorosità di ventilazione; è consigliabile, per queste applicazioni, un bilanciamento del rotore in grado B e l'eventuale montaggio del servoventilatore indipendente.

Above rated speed, motors generate increased mechanical vibration and fan noise. Class B rotor balancing is highly recommended in these applications. Installing a separate supply fan cooling may also be advisable.

Bei Geschwindigkeiten über die Nennwerte hinaus, weisen die Motoren höhere mechanische Schwingungen und mehr Funktionsgeräusche bei der Belüftung auf. Bei diesen Applikationen wird ein Auswuchten des Rotors im Grad B und eine eventuelle Montage des unabhängig funktionierenden Servoventilators empfohlen.

A des vitesses supérieures à la vitesse nominale, les moteurs présentent plus de vibrations mécaniques et de bruit de ventilation ; pour ces applications, il est conseillé d'effectuer un équilibrage du rotor en niveau B et de monter éventuellement un servoventilateur indépendant.

Il servoventilatore e, se presente, il freno elettromagnetico devono sempre essere alimentati direttamente da rete.

Remote-controlled fan and brake (if fitted) must always be connected direct to mains power supply.

Der Servoventilator und, falls vorhanden, die elektromagnetische Bremse müssen immer direkt über das Netz gespeist werden.

Le servoventilateur et, si présent, le frein électromagnétique doivent toujours être alimentés directement par le réseau.

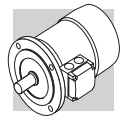

Frequenza massima di avviamento Z

Nelle tabelle dei dati tecnici motori è indicata la max frequenza di inserzione a vuoto Z_0 con $I = 50\%$ riferita alla versione autofrenante. Questo valore definisce il numero max di avviamenti orari a vuoto che il motore può sopportare senza superare la max temperatura ammessa dalla classe di isolamento F. Nel caso pratico di motore accoppiato ad un carico esterno con potenza assorbita P_r , massa inerziale J_c e coppia resistente media durante l'avviamento M_L , il numero di avviamenti ammissibile si può calcolare in modo approssimato con la seguente formula:

Permissible starts per hour, Z

The rating charts of brakemotors lend the permitted number of starts Z_0 , based on 50% intermittence and for unloaded operation. The catalogue value represents the maximum number of starts per hour for the motor without exceeding the rated temperature for the insulation class F. To give a practical example for an application characterized by inertia J_c , drawing power P_r and requiring mean torque at start-up M_L the actual number of starts per hour for the motor can be calculated approximately through the following equation:

Maximale Schaltungshäufigkeit Z

In den Tabellen mit den Technischen Daten der Motoren ist die maximale Schaltungshäufigkeit im Leerlauf Z_0 bei relativer Einschaltdauer $I = 50\%$ bezüglich auf die Bremsausführung. Dieser Wert definiert die maximale Anzahl von Anfahrten im Leerlauf pro Stunde, die der Motor ertragen kann, ohne die durch die Isolierstoffklasse F festgelegte maximal zulässige Temperatur zu überschreiten. Im praktischen Fall eines mit einer externen Last verbundenen Motors mit einer Leistungsaufnahme von P_r , Trägheitsmasse J_c und mittlerem Gegenmoment während des Anfahrens von M_L kann die zulässige Anzahl Anfahrten mit folgender Formel approximativ berechnet werden:

Fréquence maximum de démarrage Z

Dans les tableaux des caractéristiques techniques des moteurs se trouve la fréquence maximum d'insertion à vide Z_0 avec intermittence $I = 50\%$ référée à la version frein. Cette valeur définit un nombre maximum de démarrages horaires à vide que le moteur peut supporter sans dépasser la température maximum admise par la classe d'isolation F. Dans le cas pratique de moteur accouplé à une charge extérieure avec puissance absorbée P_r , masse inertielle J_c et couple résistant moyen pendant le démarrage M_L , le nombre de démarrages admissible peut se calculer de façon approximative avec la formule suivante :

$$Z = \frac{Z_0 \cdot K_c \cdot K_d}{K_J}$$

dove:

$$K_J = \frac{J_m + J_c}{J_m} = \text{fattore di inerzia}$$

$$K_c = \frac{M_a - M_L}{M_a} = \text{fattore di coppia}$$

K_d = fattore di carico
vedi tabella (A47)

where:

$$K_J = \frac{J_m + J_c}{J_m} = \text{inertia factor}$$

$$K_c = \frac{M_a - M_L}{M_a} = \text{torque factor}$$

K_d = load factor
see table (A47)

wobei gilt:

$$K_J = \frac{J_m + J_c}{J_m} = \text{Trägheitsfaktor}$$

$$K_c = \frac{M_a - M_L}{M_a} = \text{Drehmomentsfaktor}$$

K_d = Lastfaktor
siehe Tabelle (A47)

où:

$$K_J = \frac{J_m + J_c}{J_m} = \text{facteur d'inertie}$$

$$K_c = \frac{M_a - M_L}{M_a} = \text{facteur de couple}$$

K_d = facteur de charge
voir tableau (A47)

(A47)

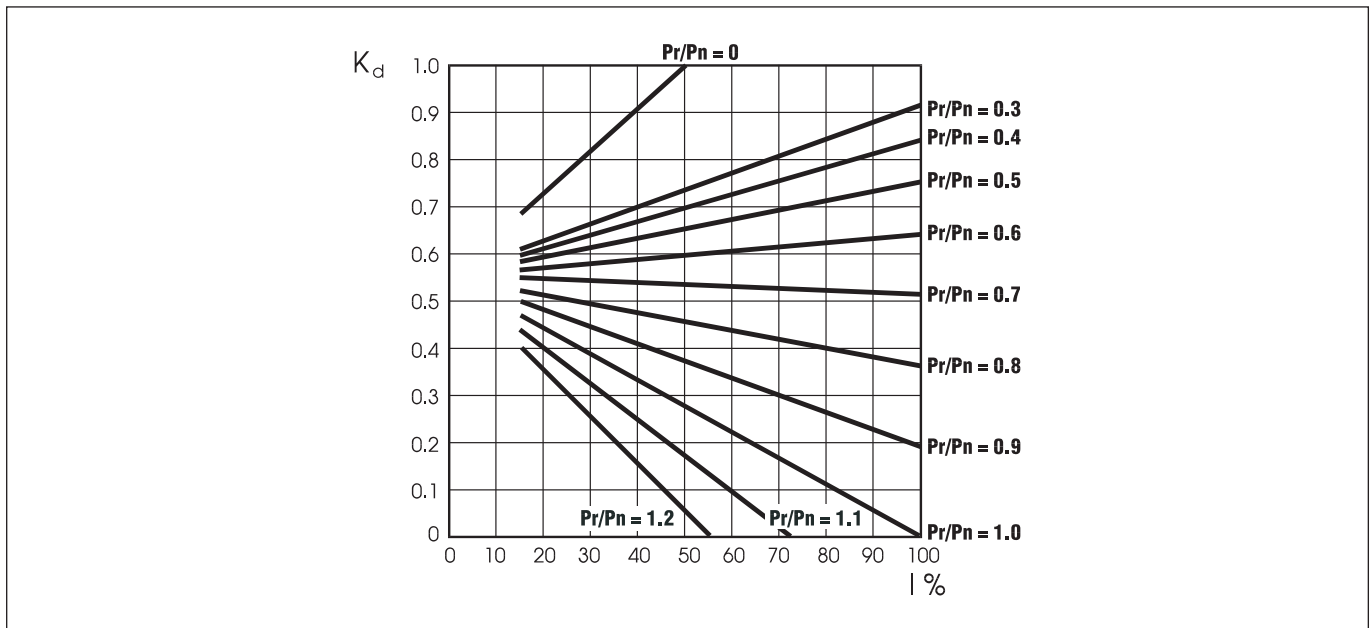

Con il numero di avviamenti così ottenuto si dovrà in seguito verificare che il massimo lavoro di frenatura sia compatibile con la capacità termica del freno W_{max} indicata nella tabella (A54).

If actual starts per hour is within permitted value (Z) it may be worth checking that braking work is compatible with brake (thermal) capacity W_{max} also given in table (A54) and dependent on the number of switches (c/h).

Auf Grundlage der so berechneten Anzahl Schaltungen muß man dann prüfen, ob die maximale Bremsarbeit mit der Wärmegrenzleistung der Bremse W_{max} kompatibel ist, die in die Tabelle (A54) angegeben ist.

Avec le nombre de démarrages ainsi obtenu, il faudra ensuite vérifier que le travail maximum de freinage soit compatible avec la capacité thermique du frein W_{max} indiquée dans le table (A54).

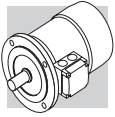

M5 - MOTORI ASINCRONI AUTOFRENANTI

Funzionamento

L'esecuzione autofrenante prevede l'impiego di freni a pressione di molle alimentati in c.c. (tipo FD) o in c.a. (tipo FA, BA). Tutti i freni funzionano secondo il principio di sicurezza, ossia intervengono in seguito alla pressione esercitata dalle molle, in mancanza di alimentazione.

M5 - ASYNCHRONOUS BRAKE MOTORS

Operation

Versions with incorporated brake use spring-applied DC (FD option) or AC (FA, BA options) brakes. All brakes are designed to provide fail-safe operation, meaning that they are applied by spring-action in the event of power failure.

M5 - DREHSTROMBREMS- MOTOREN

Betriebsweise

Die selbstbremsende Ausführung der Motoren sieht den Einsatz von Federdruckbremsen vor, die mit Gleichstrom (Typ FD) oder mit Wechselstrom (Typ FA, BA) gespeist werden. Alle Bremsen arbeiten gemäß dem Sicherheitsprinzip, d.h. sie greifen, im Fall eines Stromausfalls in Folge eines auf die Feder ausgeübten Drucks ein.

M5 - MOTEURS FREIN ASYNCHRONES

Fonctionnement

L'exécution avec frein prévoit l'utilisation de freins à pression de ressorts alimentés en c.c. (type FD) ou en c.a. (type FA, BA). Tous les freins fonctionnent selon le principe de sécurité, c'est-à-dire qu'ils interviennent suite à la pression exercée par les ressorts, en cas de coupure d'alimentation.

(A48)

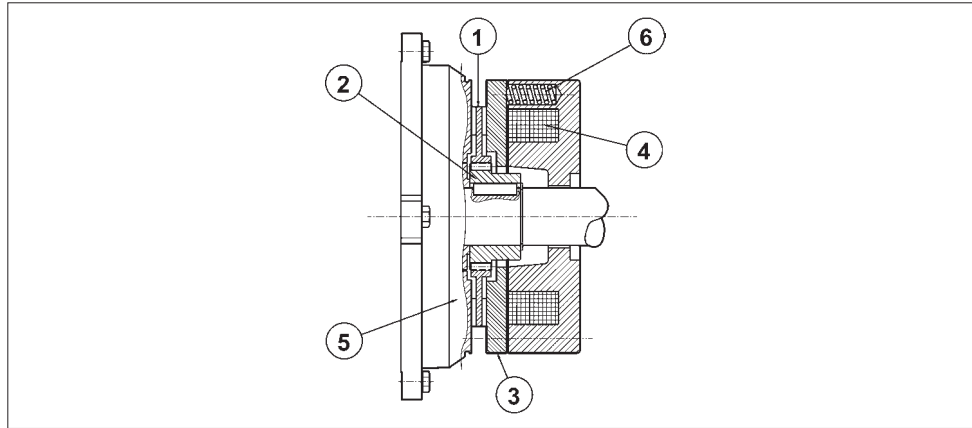

Legenda:

- ① disco
- ② mozzo
- ③ ancora mobile
- ④ bobina
- ⑤ scudo post.motore
- ⑥ molle

Key:

- ① brake disc
- ② disc carrier
- ③ pressure plate
- ④ brake coil
- ⑤ motor rear shield
- ⑥ brake springs

Zeichenerklärung:

- ① Brems scheibe
- ② Nabe
- ③ Beweglicher Anker
- ④ Ringspule
- ⑤ Motorschild
- ⑥ Schußfedern

Légende:

- ① disque
- ② moyeu d'entraînement
- ③ disque de freinage
- ④ bobine de frein
- ⑤ flasque-frein
- ⑥ ressort de frein

In mancanza di tensione, l'ancora mobile spinta dalle molle di pressione blocca il disco freno tra la superficie dell'ancora stessa e lo scudo motore impedendo la rotazione dell'albero. Quando la bobina viene eccitata, l'attrazione magnetica esercitata sull'ancora mobile vince la reazione elastica delle molle e libera il disco freno, e conseguentemente l'albero motore con esso solidale.

When voltage is interrupted, pressure springs push the armature plate against the brake disc. The disc becomes trapped between the armature plate and motor shield and stops the shaft from rotation. When the coil is energized, a magnetic field strong enough to overcome spring action attracts the armature plate, so that the brake disc – which is integral with the motor shaft – is released.

Wenn die Spannungsversorgung abfällt, sorgt der bewegliche, von den Druckfedern geschobene Anker für die Blockierung der Bremsscheibe zwischen der Ankerfläche und dem Motorschild und blockiert damit den Rotor. Wird die Spule erregt, kommt es durch den magnetischen auf den beweglichen Anker wirkenden Anzug zur Überwindung der elastischen Federkraft und zum Lösen der Bremsscheibe, wodurch der rotor wieder freigegeben wird.

En cas de coupure de courant, l'armature mobile, poussée par les ressorts, bloque le disque de frein entre la surface de l'armature et le bouclier moteur en empêchant la rotation de l'arbre. Lorsque la bobine est excitée, l'attraction magnétique exercée sur l'armature mobile annule la réaction élastique des ressorts et libère le disque de frein, et par conséquent l'arbre moteur, qui est solidaire.

Caratteristiche generali

- Coppie frenanti elevate (generalmente $M_b \approx 2 M_n$) e regolabili.
- Disco freno con anima in acciaio a doppia guarnizione d'attrito (materiale a bassa usura, senza amianto).
- Cava esagonale sull'albero motore, lato ventola (N.D.E.), per rotazione manuale (non prevista quando sono presenti le opzioni PS, RC, TC, U1, U2, EN1, EN2, EN3).
- Sblocco meccanico manuale.
- Trattamento anticorrosivo di tutte la superfici del freno.
- Isolamento in classe F

Most significant features

- High braking torques (normally $M_b \approx 2 M_n$), braking torque adjustment.
- Steel brake disc with double friction lining (low-wear, asbestos-free lining).
- Hexagonal seat on motor shaft fan end (N.D.E.) for manual rotation (not compatible with options PS, RC, TC, U1, U2, EN1, EN2, EN3).
- Manual release lever.
- Corrosion-proof treatment on all brake surfaces.
- Insulation class F

Allgemeine Eigenschaften

- Hohe und regulierbare Bremsmomente (allgemein $M_b \approx 2 M_n$).
- Bremsscheibe mit Stahlkern und doppeltem Bremsbelag (Material mit geringem Verschleiß, asbestfrei).
- Sechskant hinten an der Motorwelle, auf Lüfterradseite (N.D.E.), für eine manuelle Drehung des Rotors mit einem Inbusschlüssel. (nicht lieferbar, wenn die Optionen PS, RC, TC, U1, U2, EN1, EN2, EN3) bestellt wurden.
- Manuell zu betätigende, mechanische Bremslüftvorrichtung.
- Korrosionsschutzbehandlung an allen Flächen der Bremse.
- Isolierung in Klasse F

Caractéristiques générales

- Couples de freinage élevés (généralement $M_b \approx 2 M_n$) et réglables.
- Disque de frein avec structure en acier à double garniture de frottement (matière à faible usure, sans amiante).
- Empreinte hexagonale sur l'arbre moteur, côté ventilateur (N.D.E.), pour la rotation manuelle (non prévue en cas de présence des options PS, RC, TC, U1, U2, EN1, EN2, EN3).
- Déblocage mécanique manuel.
- Traitement anticorrosion sur toute la surface du frein.
- Isolation en classe F

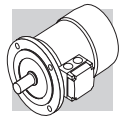

**M6 - MOTORI AUTOFRENANTI
IN C.C., TIPO BN_FD**

**M6 - DC BRAKE MOTORS
TYPE BN_FD**

**M6 - DREHSTROMBREMSMO-
TOREN MIT GLEICH-
STROMBREMSE: TYP
BN_FD**

**M6 - MOTEURS FREIN EN C.C.,
TYPE BN_FD**

Grandezze: BN 63 ... BN 200L

Frame sizes: BN 63 ... BN 200L

Baugrößen: BN 63 ... BN 200L

Tailles : BN 63 ... BN 200L

(A49)

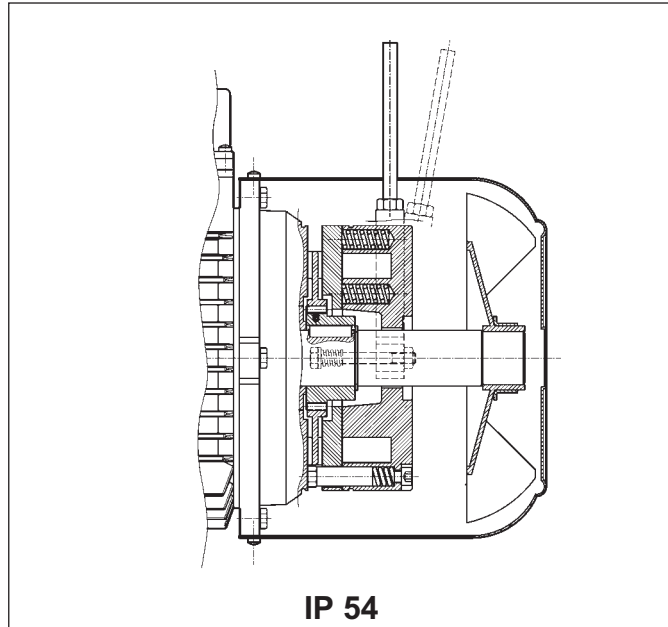

IP 54

(A50)

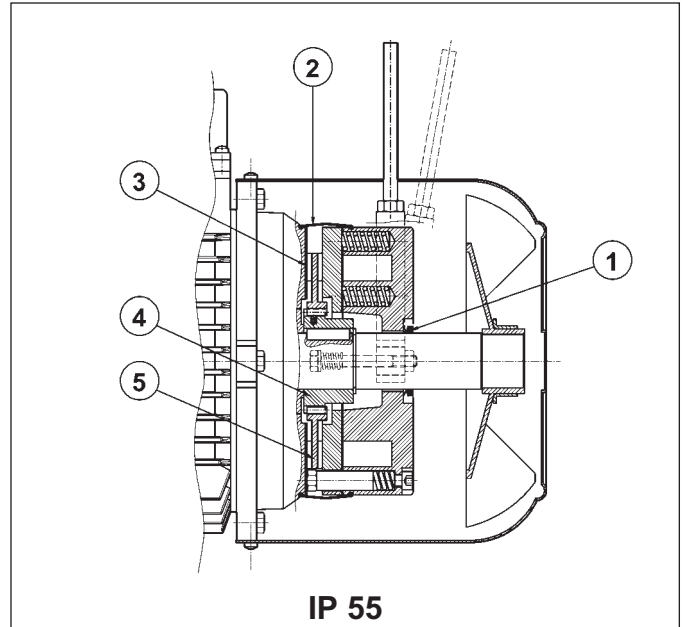

IP 55

Freno elettromagnetico con bobina toroidale in **corrente continua** fissato con viti allo scudo motore; le molle di precarico realizzano il posizionamento assiale del corpo magnete.

Il disco freno è scorrevole sul mozzo trascinatore in acciaio calettato sull'albero e previsto di molla antivibrazione.

I motori sono forniti con freno tarato in fabbrica al valore di coppia riportato nelle tabelle dati tecnici; la coppia frenante può essere regolata modificando il tipo e/o il numero delle molle.

A richiesta, i motori possono essere previsti di leva per lo sblocco manuale con ritorno automatico (**R**) o con mantenimento della posizione di rilascio freno (**RM**); per la posizione angolare della leva di sblocco vedi descrizione della relativa variante alla pag. 194.

Il freno FD garantisce elevate prestazioni dinamiche e bassa rumorosità; le caratteristiche d'intervento del freno in corrente continua possono essere ottimizzate in funzione dell'applicazione, utilizzando i vari tipi di alimentatore disponibili e/o realizzando l'opportuno cablaggio.

Direct current toroidal-coil electromagnetic brake bolted onto motor shield. Preloading springs provide axial positioning of magnet body.

Brake disc slides axially on steel hub shrunk onto motor shaft with anti-vibration spring.

Brake torque factory setting is indicated in the corresponding motor rating charts. Braking torque may be modified by changing the type and/or number of springs.

At request, motors may be equipped with manual release lever with automatic return (R**) or system for holding brake in the released position (**RM**). See variant at page 194 for available release lever locations.**

FD brakes ensure excellent dynamic performance with low noise. DC brake operating characteristics may be optimized to meet application requirements by choosing from the various rectifier/power supply and wiring connection options available.

Elektromagnetische Bremse mit Ringwicklungsspule für **Gleichstromspannung**, die mittels Schrauben am hinteren Motorschild befestigt ist. Die Federn sorgen für die axiale Ausrichtung des Magnetkörpers.

Die Bremsscheibe gleitet axial auf der Mitnehmernabe aus Stahl, die über eine Paßfeder mit der Motorwelle verbunden und mit einer Schwingungsdämpfung ausgestattet ist.

Die Motoren werden vom Hersteller auf den in der Tabelle der technischen Daten angegebenen Bremsmoment eingestellt; das Bremsmoment kann durch das Ändern des Typs und/oder der Anzahl der Federn reguliert werden.

Auf Anfrage können die Motoren mit einem Bremslüfthebel für die manuelle Lüftung der Bremse mit selbstständiger Rückstellung (**R**) ohne Arretierung oder mit arretierbarem Lüfthebel (**RM**) geliefert werden. Die Festlegung der Position des Bremslüfthebel in Abhängigkeit von der Klemmkastenlage erfolgt durch die Option auf Seite 194.

Die Bremse vom Typ FD garantiert hohe dynamische Leistungen und niedrige Laufgeräusche. Die Ansprechigenschaften der Bremse unter Gleichstrom können in Abhängigkeit zur jeweiligen Anwendung durch den Einsatz der verschiedenen verfügbaren Gleichrichter oder durch eine entsprechenden Anschluß der Bremse optimiert werden.

Frein électromagnétique avec bobine toroïdale en **courant continu**, fixé avec des vis au bouclier moteur; les ressorts de précharge réalisent le positionnement axial de la bobine.

Le disque frein coulisse de façon axiale sur le moyeu d'entraînement en acier calé sur l'arbre et doté de ressort antivibration.

Les moteurs sont fournis avec frein préréglé en usine à la valeur de couple indiquée dans les tableaux des caractéristiques techniques; le couple de freinage peut être réglé en modifiant le type et/ou le nombre de ressorts.

Sur demande, les moteurs peuvent être équipés de levier pour le déblocage manuel avec retour automatique (**R**) ou avec maintien de la position de déblocage frein (**RM**); pour la position angulaire du levier de déblocage, voir description de la variante correspondante à la page 194.

Le frein FD garantit des performances dynamiques élevées et un faible niveau de bruit; les caractéristiques d'intervention du frein en courant continu peuvent être optimisées en fonction de l'application en utilisant les différents types de dispositifs d'alimentation disponibles et/ou en réalisant un câblage approprié.

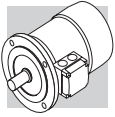

Grado di protezione

L'esecuzione standard prevede il grado di protezione IP54. In opzione il motore autofrenante tipo FD viene fornito con grado di protezione **IP 55**, prevedendo le seguenti varianti costruttive:

- ① anello V-ring posizionato sull'albero motore N.D.E.
- ② fascia di protezione in gomma
- ③ anello in acciaio inox interposto tra scudo motore e disco freno
- ④ mozzo trascinatore in acciaio inox
- ⑤ disco freno in acciaio inox

Degree of protection

Standard protection class is IP54.

Brake motor FD is also available in protection class **IP 55**, which mandates the following variants:

- ① V-ring at N.D.E. of motor shaft
- ② dust and water-proof rubber boot
- ③ stainless steel ring placed between motor shield and brake disc
- ④ stainless steel hub
- ⑤ stainless steel brake disc

Schutzart

Die Standardausführung ist Schutzart IP54 vor. Optional kann der Bremsmotor vom Typ FD in der Schutzart **IP 55** geliefert werden, wobei sind folgende Komponenten eingesetzt werden:

- ① V-Ring an der Motorwelle N.D.E.
- ② Schutzring aus Gummi
- ③ Ring aus rostfreiem Stahl zwischen Motorschild und
- ④ Bremsscheibe Mitnehmer-nabe aus rostfreiem Stahl
- ⑤ Bremsscheibe aus rostfreiem Stahl

Degré de protection

L'exécution standard prévoit le degré de protection IP54.

En option, le moteur frein type FD est fourni avec degré de protection **IP 55**, en prévoyant les variantes de construction suivantes :

- ① bague V-ring positionnées sur l'arbre moteur N.D.E.
- ② bande de protection en caoutchouc
- ③ bague en acier inox interposée entre le bouclier moteur et le disque de frein
- ④ moyeu d'entraînement en acier inox
- ⑤ disque frein en acier inox

Alimentazione freno FD

L'alimentazione della bobina freno in c.c. è prevista per mezzo di opportuno raddrizzatore montato all'interno della scatola coprimorsetti e già cablato alla bobina del freno.

Per motori a singola polarità è inoltre previsto di serie il collegamento del raddrizzatore alla morsettiera motore.

Indipendentemente dalla frequenza di rete, la tensione standard di alimentazione del raddrizzatore V_B ha il valore indicato nella tabella (A51) qui di seguito:

FD brake power supply

A rectifier accommodated inside the terminal box feeds the DC brake coil. Wiring connection across rectifier and brake coil is performed at the factory.

On all single-pole motors, rectifier is connected to the motor terminal board.

Rectifier standard power supply voltage V_B is as indicated in the following table (A51), regardless of mains frequency:

Spannungsversorgung der Bremse FD

Die Versorgung der Gleichstrombremsspule erfolgt über einen Gleichrichter im Klemmenkasten der bei Lieferung, wenn nicht anders bestellt, bereits mit der Bremsspule verkabelt ist.

Bei den einpoligen Motoren ist serienmäßig der Anschluss des Gleichrichters an die Motorspannung vorgesehen. Unabhängig von der Netzfrequenz erfolgt die Versorgung des Gleichrichters V_B über die in der nachstehenden Tabelle (A51) angegebenen Standardspannung:



Alimentation frein FD

L'alimentation de la bobine de frein en c.c. est prévue au moyen d'un redresseur approprié monté à l'intérieur de la boîte à bornes et déjà câblé à la bobine de frein.

De plus, pour les moteurs à simple polarité, le raccordement du redresseur au bornier moteur est prévu de série.

Indépendamment de la fréquence du réseau, la tension standard d'alimentation du redresseur V_B correspond à la valeur indiquée dans le tableau (A51) ci-dessous :

(A51)

2, 4, 6 P				1 speed	
		BN_FD / M_FD		alimentazione freno da morsettiera brake connected to terminal board power supply Bremsversorgung über die Motorspannung Alimentation frein depuis boîte à bornes	alimentazione separata separate power supply Separate Versorgung Alimentation séparée
		$V_{mot} \pm 10\%$ 3 ~	$V_B \pm 10\%$ 1 ~		
BN 63...BN 132	M05...M4LB	230/400 V – 50 Hz	230 V	standard	specificare $V_B SA$ o $V_B SD$ specify $V_B SA$ or $V_B SD$ $V_B SA$ oder $V_B SD$ angeben spécifier $V_B SA$ ou $V_B SD$
BN 160...BN 200	M4LC...M5	400/690 V – 50 Hz	400 V	standard	specificare $V_B SA$ o $V_B SD$ specify $V_B SA$ or $V_B SD$ $V_B SA$ oder $V_B SD$ angeben spécifier $V_B SA$ ou $V_B SD$



Per i motori a doppia polarità l'alimentazione standard del freno è da linea separata con tensione d'ingresso al raddrizzatore V_B come indicato in tabella (A52):

Switch-pole motors feature a separate power supply line for the brake with rectifier input voltage V_B as indicated in the table (A52):

Die polumschaltbaren Motoren müssen immer mit separater Bremsversorgungsspannung betrieben werden, deshalb erfolgt die Lieferung standardmäßig ohne Anschluß der Bremse an die Motorspannung, da diese mit einer am Eingang des Gleichrichters V_B anliegenden Spannung versorgt werden muß, entsprechend Werte in der nachstehenden Tabelle (A52):

Pour les moteurs à double polarité, l'alimentation standard du frein dérive d'une ligne séparée avec tension d'entrée au redresseur V_B comme indiqué dans le tableau (A52) :

(A52)

2/4, 2/6, 2/8, 2/12, 4/6, 4/8 P				2 speed	
		BN_FD / M_FD		alimentazione freno da morsettiera brake powered via terminal board Bremsversorgung über die Motorspannung Alimentation frein depuis boîte à bornes	alimentazione separata separate power supply Separate Versorgung Alimentation séparée
		$V_{mot} \pm 10\%$ 3 ~	$V_B \pm 10\%$ 1 ~		
BN 63...BN 132	M05...M4LB	400 V – 50 Hz	230 V		specificare $V_B SA$ o $V_B SD$ specify $V_B SA$ or $V_B SD$ $V_B SA$ oder $V_B SD$ angeben spécifier $V_B SA$ ou $V_B SD$

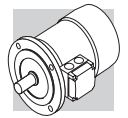

Il raddrizzatore è del tipo a diodi a semionda ($V_{c.c} \approx 0,45 \times V_{c.a.}$) ed è disponibile nelle versioni **NB**, **SB**, **NBR** e **SBR**, come dettagliato nella tabella (A53) seguente:

The diode half-wave rectifier ($V_{DC} \approx 0,45 \times V_{AC}$) is available in versions **NB**, **SB**, **NBR** e **SBR**, as detailed in the table (A53) below:

Bei dem Gleichrichter handelt es sich um einen Typ mit Halbwel-lendioden ($V_{c.c} \approx 0,45 V_{c.a.}$). Er ist in den Versionen **NB**, **SB**, **NBR** und **SBR**, gemäß den De-tails in der nachstehenden Ta-belle (A53), verfügbar:

Le redresseur est du type à dio-des à demi-onde ($V_{c.c} \approx 0,45 \times V_{c.a.}$) et il est disponible dans les versions **NB**, **SB**, **NBR** et **SBR**, comme indiqué de façon détaillée dans le tableau (A53) suivant :

(A53)

		freno brake Bremsse frein						
			standard	a richiesta at request auf Anfrage Sur demande				
BN 63	M05	FD 02						
BN 71	M1	FD 03						
		FD 53						
BN 80	M2	FD 04						
BN 90S	—	FD 14						
BN 90L	—	FD 05						
BN 100	M3	FD 15						
—		FD 55						
BN 112	—	FD 06S						
BN 132...160MR	M4	FD 56						
BN 160L - BN 180M	M5	FD 06						
BN 180L - NM 200L	—	FD 07						

(*) $t_{2c} < t_{2r} < t_2$

Il raddrizzatore **SB** a controllo elettronico dell'eccitazione, riduce i tempi di sblocco del freno sovraccitando l'elettromagnete nei primi istanti d'inserzione, per passare poi al normale funzionamento a semionda a distacco del freno avvenuto.

Rectifier **SB** with electronic energizing control over-energizes the electromagnet upon power-up to cut brake release response time and then switches to normal half-wave operation once the brake has been released.

Der Gleichrichter **SB** mit elektronischer Kontrolle der Erregung reduziert die Bremslösezeiten, indem er die Bremsspule in den ersten Momenten der Einschaltung übermäßig erregt, um dann, nach erfolgter Bremslösung, in die normale Halbwellenfunktion umzuschalten.

Le redresseur **SB** à contrôle électronique de l'excitation réduit les temps de déblocage du frein en surexcitant l'électro-aimant durant les premiers instants d'enclenchement pour passer ensuite au fonctionnement normal à demi-onde une fois le frein désactivé.

L'impiego del raddrizzatore tipo **SB** è sempre da prevedere nei casi di:

Use of the **SB** rectifier is mandatory in the event of:

Der Einsatz eines Gleichrichters vom Typ **SB** wird in folgenden Fällen empfohlen:

L'utilisation du redresseur type **SB** doit toujours être prévue dans les cas suivants :

- elevato numero di interventi orari
- tempi di sblocco freno ridotti
- elevate sollecitazioni termiche del freno

- high number of operations per hour
- reduced brake release response time
- brake is exposed to extreme thermal stress

- hohe Anzahl von Schaltungen pro Stunde
- schnelle Bremsansprechzeiten
- starke thermische Beanspruchungen der Bremse

- nombre d'interventions horaires élevé
- temps de déblocage frein réduits
- sollicitations thermiques du frein élevées

Per applicazioni dove è richiesto un rapido rilascio del freno sono disponibili a richiesta i raddrizzatori **NBR** o **SBR**. Questi raddrizzatori completano i tipi **NB** e **SB**, integrando nel cir-

Rectifiers **NBR** or **SBR** are available for applications requiring quick brake release response. These rectifiers complement the **NB** and **SB** types as their elec-

Für die Anwendungen, bei denen eine schnelle Ansprechzeit der Bremse gefordert wird, können auf Anfrage die Gleichrichter **NBR** oder **SBR** geliefert werden. Diese Gleichrichter erweitern die

Pour les applications nécessitant un déblocage rapide du frein, sur demande les redresseurs **NBR** ou **SBR** sont disponibles. Ces redresseurs complètent les types **NB** et **SB**, en intégrant

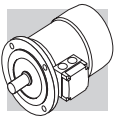

cuito elettronico un interruttore statico che interviene diseccando rapidamente il freno in caso di mancanza di tensione. Questa soluzione consente di ridurre i tempi di rilascio del freno evitando ulteriori cablaggi e contatti esterni. Per il migliore utilizzo dei raddrizzatori **NBR** e **SBR** è richiesta l'alimentazione separata del freno. Tensioni disponibili: 230V ± 10%, 400V ± 10%, 50/60 Hz.

*tronic circuit incorporates a static switch that de-energizes the brake quickly in the event voltage is missing. This arrangement ensures short brake release response time with no need for additional external wiring and contacts. Optimum performance of rectifiers **NBR** and **SBR** is achieved with separate brake power supply. Available voltages: 230V ± 10%, 400V ± 10%, 50/60 Hz.*

Funktion der Typen **NB** und **SB**, indem in dem elektronischen Schaltkreis ein statischen Schalter integriert ist, durch dessen Auslösen die Bremse im Fall eines Spannungsausfalls schnell abgeregt wird. Diese Lösung ermöglicht eine Verringerung der Ansprechzeiten der Bremse, wodurch weitere Schaltungen und externe Sensoren vermieden werden können. Im Hinblick auf einen besseren Einsatz der Gleichrichter **NBR** und **SBR** ist bei der Bremse eine separate Versorgung erforderlich. Verfügbare Spannungen: 230V ± 10%, 400V ± 10%, 50/60 Hz.

*dans le circuit électronique un interrupteur statique qui intervient en désexcitant rapidement le frein en cas de coupure de tension. Cette solution permet de réduire les temps de déblocage du frein en évitant d'autres câblages et contacts extérieurs. Pour une meilleure utilisation des redresseurs **NBR** et **SBR** l'alimentation séparée du frein est nécessaire. Tensions disponibles : 230V ± 10%, 400V ± 10%, 50/60 Hz.*

Dati tecnici freni FD

Nella tabella (A54) sottostante sono riportati i dati tecnici dei freni in c.c. tipo FD.

(A54)

FD brake technical specifications

The table (A54) below reports the technical specifications of DC brakes FD.

Technische Daten - Bremstyp FD

In der nachstehenden Tabelle (A54) werden die technischen Daten der Gleichstrombremsen vom Typ FD angegeben.

Caractéristiques techniques freins FD

Le tableau (A54) suivant indique les caractéristiques techniques des freins en c.c. type FD.

Freno Brake Bremse Frein	Coppia frenante M_b [Nm] Brake torque M_b [Nm] Bremsmoment M_b [Nm] Couple de freinage M_b [Nm]			Rilascio Release Ansprchzeit Déblocage		Frenatura Braking Bremmung Freinage		Wmax per frenata Wmax per brake operation Wmax pro Bremsung Wmax par freinage			W	P
	molle / springs feder / ressorts			t_1	t_{1s}	t_2	t_{2c}	[J]				
	6	4	2	[ms]	[ms]	[ms]	[ms]	10 s/h	100 s/h	1000 s/h		
FD02	—	3.5	1.75	30	15	80	9	4500	1400	180	15	17
FD03	5	3.5	1.75	50	20	100	12	7000	1900	230	25	24
FD53	7.5	5	2.5	60	30	100	12					
FD04	15	10	5	80	35	140	15	10000	3100	350	30	33
FD14												
FD05	40	26	13	130	65	170	20	18000	4500	500	50	45
FD15	40	26	13	130	65	170	20					
FD55	55	37	18	—	65	170	20					
FD06S	60	40	20	—	80	220	25	20000	4800	550	70	55
FD56	—	75	37	—	90	150	20	29000	7400	800	80	65
FD06		100	50		—	100	150					
FD07	150	100	50	—	120	200	25	40000	9300	1000	130	65
FD08*	250	200	170	—	140	350	30	60000	14000	1500	230	100
FD09**	400	300	200	—	200	450	40	70000	15000	1700	230	120

* valori di coppia frenante ottenuti con n° 9, 7, 6 molle rispettivamente

* brake torque values obtained with 9, 7 and 6 springs, respectively

* Werte, der durch den Einsatz von jeweils 9, 7, 6 Federn erreichten Bremsmomente

* valeurs de couple de freinage obtenues respectivement avec n° 9, 7, 6 ressorts

** valori di coppia frenante ottenuti con n° 12, 9, 6 molle rispettivamente

** brake torque values obtained with 12, 9 and 6 springs, respectively

** Werte, der durch den Einsatz von jeweils 12, 9, 6 Federn erreichten Bremsmomente

** valeurs de couple de freinage obtenues respectivement avec n° 12, 9, 6 ressorts

Legenda:

t_1 = tempo di rilascio del freno con alimentatore a semionda
 t_{1s} = tempo di rilascio del freno con alimentatore a controllo elettronico dell'eccitazione
 t_2 = ritardo di frenatura con interruzione lato c.a. e alimentazione separata
 t_{2c} = ritardo di frenatura con interruzione lato c.a.e c.c. — I valori di t_1 , t_{1s} , t_2 , t_{2c} indicati nella tab. (A54) sono riferiti al freno tarato alla coppia massima, trafero medio e tensione nominale
 W_{max} = energia max per frenata
 W = energia di frenatura tra due regolazioni successive del trafero
 P_b = potenza assorbita dal freno a 20°C
 M_b = coppia frenante statica (±15%)
 s/h = avviamenti orari

Key:

t_1 = brake release time with half-wave rectifier
 t_{1s} = brake release time with over-energizing rectifier
 t_2 = brake engagement time with AC line interruption and separate power supply
 t_{2c} = brake engagement time with AC and DC line interruption — Values for t_1 , t_{1s} , t_2 , t_{2c} indicated in the tab. (A54) are referred to brake set at maximum torque, medium air gap and rated voltage
 W_{max} = max energy per brake operation
 W = braking energy between two successive air gap adjustments
 P_b = brake power absorption at 20 °C
 M_b = static braking torque (±15%)
 s/h = starts per hour

Zeichenerklärung:

t_1 = Ansprechzeit der Bremse mit Halbwellengleichrichter
 t_{1s} = Ansprechzeit der Bremse mit elektronisch gesteuerten Erregungsgleichrichter
 t_2 = Bremsverzögerung mit Unterbrechung auf Wechselstromseite und Fremdversorgung
 t_{2c} = Bremsverzögerung mit Unterbrechung auf Wechselstrom- und Gleichstromseite — Die in der Tab. (A54) angegebenen Werte t_1 , t_{1s} , t_2 , t_{2c} beziehen sich auf eine auf das max. Bremsmoment geeichte Bremse, mit mittlerem Luftspalt und Nennspannung
 W_{max} = max. Energie pro Bremsung
 W = Bremsenergie zwischen zwei Einstellungen des Luftspalts
 P_b = bei 20 ° C von der Bremse aufgenommene Leistung (50 Hz)
 M_b = statisches Bremsmoment (±15%)
 s/h = Einschaltungen pro stunde

Légende:

t_1 = temps de déblocage du frein avec dispositif d'alimentation à demi-onde
 t_{1s} = temps de déblocage du frein avec dispositif d'alimentation à contrôle électronique de l'excitation
 t_2 = retard de freinage avec interruption côté c.a. et alimentation séparée
 t_{2c} = retard de freinage avec interruption côté c.a. et c.c. — Les valeurs de t_1 , t_{1s} , t_2 , t_{2c} indiquées dans le tab. (A54) se réfèrent au frein étaloné au couple maximal, entrefer moyen et tension nominale
 W_{max} = énergie max. par freinage
 W = énergie de freinage entre deux réglages successifs de l'entrefer
 P_b = puissance absorbée par le frein à 20 °C
 M_b = couple de freinage statique (±15%)
 s/h = démarrages horaires

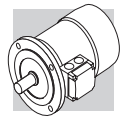

Collegamenti freno FD

I motori standard ad una velocità sono forniti con il collegamento del raddrizzatore alla morsettiera motore già realizzato in fabbrica. Per motori a 2 velocità, e dove è richiesta l'alimentazione del freno separata, prevedere il collegamento al raddrizzatore in accordo alla tensione freno V_B indicata nella targhetta del motore. **Data la natura induttiva del carico, per il comando del freno e per l'interruzione lato corrente continua devono essere utilizzati contatti con categoria d'impiego AC-3 secondo IEC 60947-4-1.**

Tabella (A55) - Alimentazione freno dai morsetti motore ed interruzione lato a.c.

Tempo di arresto t_2 ritardato e funzione delle costanti di tempo del motore. Da prevedere quando sono richiesti avviamenti/arresti progressivi.

Tabella (A56) - Bobina freno con alimentazione separata ed interruzione lato c.a.

Tempo di arresto normale ed indipendente dal motore. Si realizzano i tempi di arresto t_2 indicati nella tabella (A54).

Tabella (A57) - Bobina freno con alimentazione dai morsetti motore ed interruzione lato c.a. e c.c.

Arresto rapido con i tempi d'intervento t_{2c} indicati in tabella (A54).

(A55)

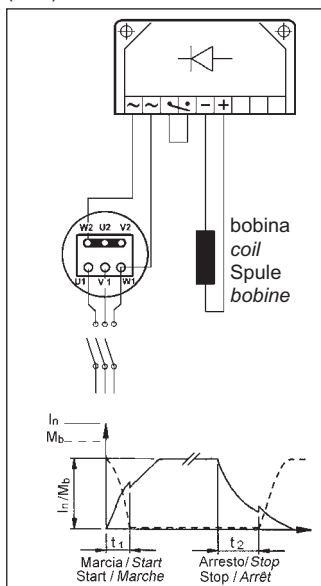

Le tabelle da (A55) a (A58) riportano gli schemi tipici di collegamento per alimentazione 400 V, motori 230/400V collegati a stella e freno 230 V.

FD brake connections

On standard single-pole motors, the rectifier is connected to the motor terminal board at the factory.

For switch-pole motors and where a separate brake power supply is required, connection to rectifier must comply with brake voltage V_B stated in motor name plate.

Because the load is of the inductive type, brake control and DC line interruption must use contacts from the usage class AC-3 to IEC 60947-4-1.

Table (A55) - Brake power supply from motor terminals and AC line interruption

Delayed stop time t_2 and function of motor time constants. Mandatory when soft-start/stops are required.

Table (A56) - Brake coil with separate power supply and AC line interruption

Normal stop time independent of motor. Achieved stop times t_2 are indicated in the table (A54).

Table (A57) - Brake coil power supply from motor terminals and AC/DC line interruption.

Quick stop with operation times t_{2c} as per table (A54).

Table (A58) - Brake coil with separate power supply and AC/DC line interruption.

Stop time decreases by values t_{2c} indicated in the table (A54).

(A56)

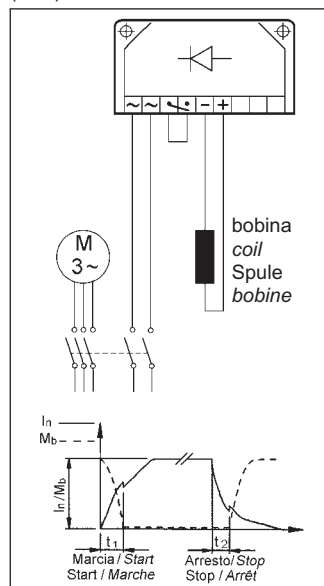

Tables (A55) through (A58) show the typical connection diagrams for 400 V power supply, star-connected 230/400V motors and 230 V brake.

Anschlüsse - Bremstyp FD

Die einpoligen Motoren werden vom Werk ab mit an die Motorspannung angeschlossenem Gleichrichter geliefert.

Für die polumschaltbaren Motoren, und Bremse mit separater Versorgung, wird in Übereinstimmung mit der auf dem Typenschild des Motors angegebenen Bremsspannung V_B der Anschluss an den Gleichrichter vorgesehen.

Da es sich bei der Bremsleistung um eine induktive Kraft handelt, müssen gemäß IEC 60947-4-1 für die Steuerung der Bremse und die Unterbrechung der Gleichstromseite Kontakte der Kategorie AC-3 verwendet werden.

Tabelle (A55) - Bremsversorgung über die Motorspannung und Unterbrechung der Wechselstromseite.

Verzögerter und von den Zeitkonstanten des Motors abhängige Haltezeit t_2 . Vorzusehen, wenn progressive Starts/Stops erforderlich sind.

Tabelle (A56) - Bremsspule mit separater Spannungsversorgung und Unterbrechung der Wechselstromseite.

Normale und vom Motor unabhängige Stoppzeiten. Es werden die in der Tabelle (A54) angegebenen Stoppzeiten t_2 realisiert.

Tabelle (A57) - Bremsspule mit Versorgung über die Motorspannung und Unterbrechung der Gleich- und der Wechselstromseite.

Schneller Stopp mit den in der Tabelle (A54) angegebenen Ansprechzeiten t_{2c} .

Tabelle (A58) - Bremsspule mit separater Spannungsversorgung und Unterbrechung der Gleich- und der Wechselstromseite.

Reduzierte Stoppzeiten der in der Tabelle (A54) angegebenen Werte t_{2c} .

(A57)

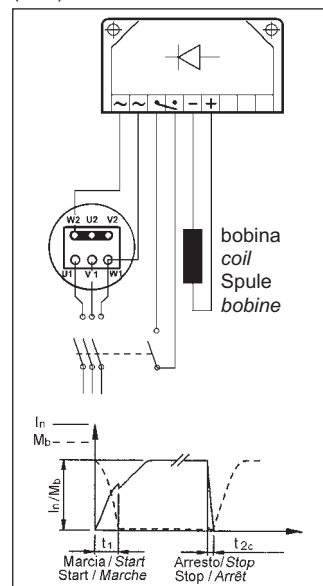

In den Tabellen (A55) bis (A58) werden die typischen Schaltungen für Versorgung mit 400 V, Motoren 230/400V mit Sternschaltung und einer Bremsspannung von 230 V wiedergegeben.

Raccordamenti freno FD

Les moteurs standard à une vitesse sont fournis avec le raccordement du redresseur au bornier moteur déjà réalisé en usine.

Pour les moteurs à 2 vitesses, et lorsqu'une alimentation séparée du frein est requise, prévoir le raccordement au redresseur conformément à la tension frein V_B indiquée sur la plaque signalétique du moteur.

Etant donné la nature inductive de la charge, pour la commande du frein et l'interruption côté courant continu, il est nécessaire d'utiliser des contacts avec catégorie d'utilisation AC-3 selon la norme IEC 60947-4-1.

Tableau (A55) - Alimentation frein depuis bornes moteur et interruption côté c.a.

Temps d'arrêt t_2 retardé et fonction des constantes de temps du moteur. A prévoir lorsque des démarrages/arrests progressifs sont requis.

Tableau (A56) - Bobine de frein avec alimentation séparée et interruption côté c.a.

Temps d'arrêt normal et indépendant du moteur. Les temps d'arrêts t_2 sont ceux indiqués dans le tableau (A54).

Tableau (A57) - Bobine de frein avec alimentation depuis les bornes moteur et interruption côté c.a. et c.c.

Arrêt rapide avec les temps d'intervention t_{2c} indiqués dans le tableau (A54).

Tableau (A58) - Bobine de frein avec alimentation séparée et interruption côté c.a. et c.c.

Temps d'arrêt réduit selon les valeurs t_{2c} indiquées dans le tableau (A54).

(A58)

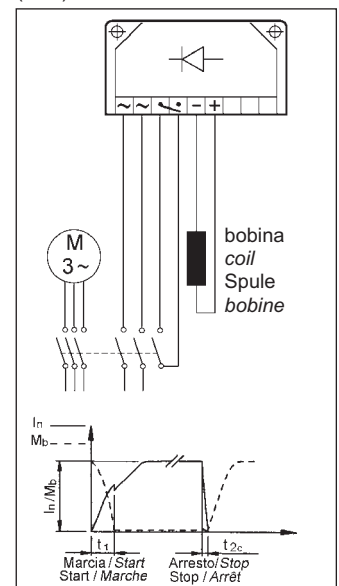

Les tableaux de (A55) à (A58) indiquent les schémas typiques de branchement pour une alimentation de 400 V, moteurs 230/400V raccordés en étoile et frein 230 V.

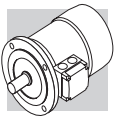

**M7 - MOTORI AUTOFRENANTI
IN C.A., TIPO BN_FA**

**M7 - AC BRAKE MOTORS
TYPE BN_FA**

**M7 - WECHSELSTROM-
BREMSMOTOREN-TYP
BN_FA**

**M7 - MOTEURS FREIN EN C.A.,
TYPE BN_FA**

Grandezze: BN 63 ... BN 180M

Frame sizes: BN 63 ... BN 180M

Baugrößen: BN 63 ... BN 180M

Tailles : BN 63 ... BN 180M

(A59)

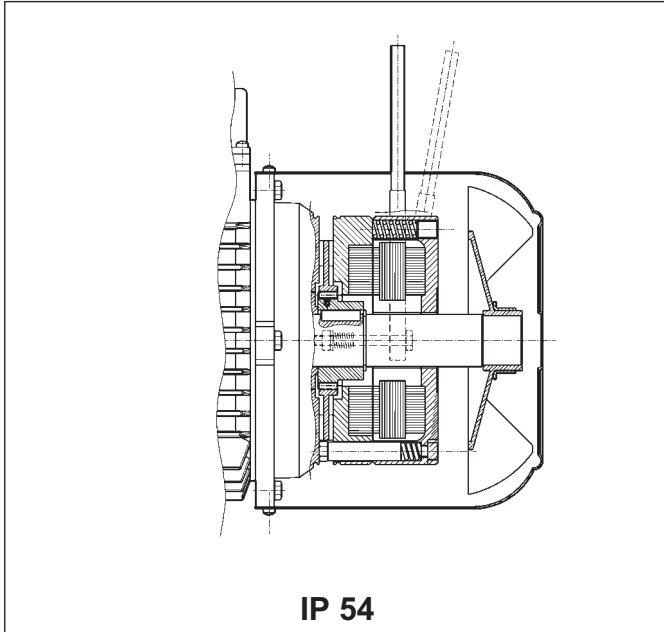

IP 54

(A60)

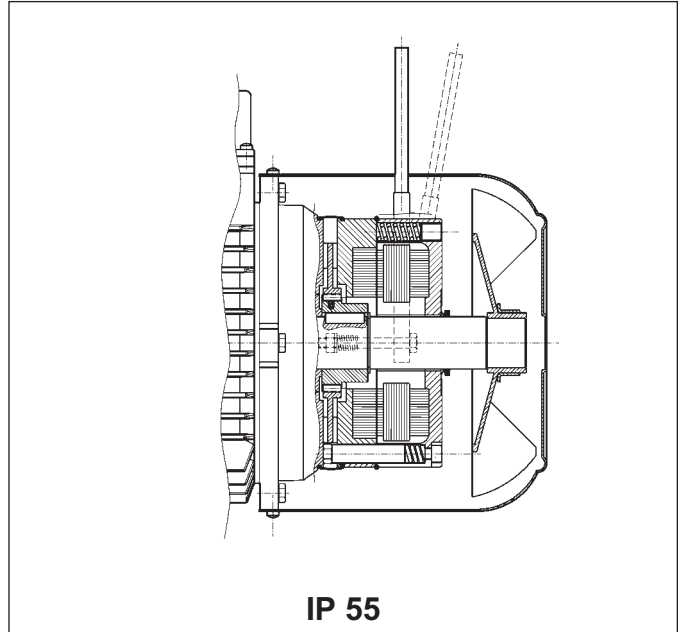

IP 55

Freno elettromagnetico con alimentazione in **corrente alternata** trifase, fissato con viti allo scudo motore; le molle di precarico realizzano il posizionamento assiale del corpo magnete.

Il disco freno è scorrevole assialmente sul mozzo trascinatore in acciaio calettato sull'albero e provvisto di molla antivibrazione. La coppia frenante è pre-impostata in fabbrica su valori che sono indicati nelle tabelle dati tecnici dei relativi motori.

L'azione del freno è inoltre modulabile, regolando con continuità la coppia frenante, tramite le viti che realizzano il precarico delle molle; il campo di regolazione della coppia è: $30\% M_{bMAX} < M_b < M_{bMAX}$ (M_{bMAX} è il momento frenante max riportato in tab. (A62)).

Il freno tipo FA presenta dinamiche molto elevate che lo rendono idoneo in applicazioni dove sono richieste frequenze di avviamento elevate con tempi d'intervento molto rapidi.

A richiesta, i motori possono essere previsti di leva per lo sblocco manuale con ritorno automatico (R). Per la specifica della posizione angolare della leva vedi relativa variante alla pag. 194.

*Electromagnetic brake operates from three-phase **alternated current** power supply and is bolted onto conveyor shield. Preloading springs provide axial positioning of magnet body.*

Steel brake disc slides axially on steel hub shrunk onto motor shaft with anti-vibration spring. Brake torque factory setting is indicated in the corresponding motor rating charts.

Spring preloading screws provide stepless braking torque adjustment.

Torque adjustment range is $30\% M_{bMAX} < M_b < M_{bMAX}$ (where M_{bMAX} is maximum braking torque as shown in tab. (A62)).

Thanks to their high dynamic characteristics, FA brakes are ideal for heavy-duty applications as well as applications requiring frequent stop/starts and very fast response time.

Motors may be equipped with manual release lever with automatic return (R) at request. See variants at page 194 for available lever locations.

Elektromagnetische Bremse mit **Drehstromversorgung**, die mittels Schrauben am hinteren Motorschild befestigt ist. Die Federn sorgen dabei für die axiale Ausrichtung des Magnetkörpers.

Die Bremsscheibe (Stahl) gleitet axial auf dem sich auf dem Rotor befindlichen Mitnehmer, der über eine Paßfeder mit Motorwelle verbunden und mit einer Schwingungsdämpffeder ausgestattet ist.

Das Bremsmoment wird auf das entsprechende Motormoment eingestellt (siehe Tabelle der technischen Daten der entsprechenden Motoren).

Das Bremsmoment ist stufenlos durch über die Schrauben die die Federvorspannung einstellbar. Der Einstellbereich beträgt $30\% M_{bMAX} < M_b < M_{bMAX}$ (M_{bMAX} steht für den max. Bremsmoment, der in der Tab (A62) angegeben wird).

Die Bremse vom Typ FA zeichnet sich durch ihre hohen Dynamik aus, weshalb sie für Anwendungen geeignet sind, in denen hohe Schaltfrequenzen und schnelle Ansprechzeiten gefordert werden.

Auf Anfrage können die Motoren mit einem Lüfterhebel für die manuelle Lüftung der Bremse mit automatischer Rückstellung (R) geliefert werden. Die Angabe der Montageposition erfolgt über die Angabe der Option auf Seite 194.

*Frein électromagnétique avec alimentation en **courant alternatif** triphasé, fixé avec des vis au bouclier; les ressorts de précharge réalisent le positionnement axial de la bobine.*

Le disque frein coulisse de façon axiale sur le moyeu d'entraînement en acier, calé sur l'arbre et doté de ressort antivibration.

Le couple de freinage est pré-réglé en usine aux valeurs qui sont indiquées dans les tableaux des caractéristiques techniques des moteurs correspondants.

De plus, l'action du frein est modulable, en réglant le couple de freinage en continu au moyen des vis qui réalisent la précharge des ressorts; la plage de réglage du couple est de $30\% M_{bMAX} < M_b < M_{bMAX}$ (M_{bMAX} est le couple de freinage maximum indiqué dans le tab. (A62)).

Le frein type FA présente des caractéristiques dynamiques très élevées, il est donc adapté pour des applications nécessitant des fréquences de démarrage élevées et des temps d'intervention très rapides.

Sur demande, les moteurs peuvent être prévus avec levier pour le déblocage manuel avec retour automatique (R). Pour la spécification de la position angulaire du levier, voir variante page 194.

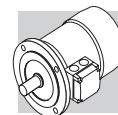

Grado di protezione

L'esecuzione standard prevede il grado di protezione IP54. In opzione, il motore autofrenante BN_FA viene fornito con grado di protezione **IP 55** prevedendo le seguenti varianti costruttive:

- anello V-ring posizionato sull'albero motore N.D.E.
- fascia di protezione in gomma
- anello O-ring

Degree of protection

Standard protection class is IP54. Brake motor BN_FA is also available in protection class **IP 55**, which mandates the following variants:

- V-ring at N.D.E. of motor shaft
- rubber protection sleeve
- O-ring

Schutzart

Die Standardausführung ist Schutzart IP54 vor. Optional kann der Bremsmotor BN_FA auch in der Schutzart **IP 55** geliefert werden, was durch die folgenden zusätzlichen Bauteile erreicht wird:

- V-Ring an der Motorwelle N.D.E.
- Schutzring aus Gummi
- O-Ring

Degré de protection

L'exécution standard prévoit le degré de protection IP54. En option, le moteur frein BN_FA est fourni avec degré de protection **IP 55**, les variations de construction suivantes sont prévues :

- bague V-ring positionné sur l'arbre moteur N.D.E.
- bande de protection en caoutchouc
- joint torique

Alimentazione freno FA

Nei motori a singola polarità l'alimentazione della bobina freno è derivata direttamente dalla morsettiera motore e la tensione del freno quindi coincide con la tensione del motore. In questo caso la tensione del freno può essere omessa dalla designazione

Per i motori a doppia polarità, e per i motori con alimentazione separata del freno, è presente una morsettiera ausiliaria con 6 terminali per il collegamento alla linea del freno. In entrambi i casi il valore di tensione del freno dovrà essere specificato in designazione.

Nella tabella seguente sono riportate le condizioni di alimentazione standard del freno in c.a. per i motori a singola e doppia polarità:

FA brake power supply

In single speed motors, power supply is brought to the brake coil direct from the motor terminal box. As a result, brake voltage and motor voltage are the same. In this case, brake voltage indication may be omitted in the designation.

Switch-pole motors and motors with separate brake power supply feature an auxiliary terminal board with 6 terminals for connection to brake line. In both cases, brake voltage indication in the designation is mandatory. The following table reports standard AC brake power supply ratings for single- and switch-pole motors:

Stromversorgung - Bremstyp FA

Bei den einpoligen Motoren wird die Versorgung der Bremsspule direkt vom Motorklemmenkasten abgenommen, das bedeutet, dass die Spannung der Bremse mit der Motorspannung übereinstimmt. In diesem Fall braucht die Bremsenspannung nicht extra angegeben werden.

Für die polumschaltbaren Motoren und für eine separate Bremsversorgung ist eine Hilfsklemmenleiste mit 6 Anschlüssen vorgesehen, die einen Anschluß der Bremse ermöglichen. In beiden Fällen muss die Bremsenspannung in der Bestellung angegeben werden.

In der nachstehenden Tabelle werden für die einpoligen und die polumschaltbaren Motoren die Standardspannungen der Wechselstrombremsen angegeben.

Alimentation frein FA

Sur les moteurs à simple polarité, l'alimentation de la bobine frein dérive directement du bornier moteur, par conséquent, la tension du frein coïncide avec la tension du moteur. Dans ce cas, la tension du frein peut être omise de la désignation.

Pour les moteurs à double polarité et les moteurs avec alimentation séparée du frein, une boîte à bornes auxiliaire avec 6 bornes pour le raccordement à la ligne du frein, est présente. Dans les deux cas, la valeur de tension du frein doit être spécifiée dans la désignation.

Le tableau suivant indique les conditions d'alimentation standard du frein en c.a. pour les moteurs à simple et double polarité :

(A61)

motori a singola polarità single-pole motor Einpolige Motoren Moteurs à simple polarité	BN 63...BN 132	BN 160...BN 180
	M05...M4LB	M4LC...M5
	230Δ / 400Y V ±10% – 50 Hz	400Δ/ 690Y V ±10% – 50 Hz
	265Δ / 460Y ±10% - 60 Hz	460Y – 60 Hz

motori a doppia polarità (alimentazione da linea separata) switch-pole motors (separate power supply line) Polumschaltbare Motoren (separate Versorgung) Moteurs à double polarité (alimentation depuis ligne séparée)	BN 63...BN 132
	M05...M4
	230Δ / 400Y V ±10% – 50 Hz
	460Y - 60 Hz

Se non diversamente specificato, l'alimentazione standard del freno è 230Δ /400Y V - 50 Hz.

Su richiesta, sono disponibili tensioni speciali, nel campo 24...690 V, 50-60 Hz.

Unless otherwise specified, standard brake power supply is 230Δ /400Y V - 50 Hz.

Special voltages in the 24...690 V, 50-60 Hz range are available at request.

Falls nicht anderweitig angegeben, beträgt die Standardversorgung der Bremse 230Δ /400Y V - 50 Hz.

Auf Anfrage können Sonderspannungen von 24...690 V, 50-60 Hz geliefert werden.

Sauf spécification contraire, l'alimentation standard du frein est 230Δ /400Y V - 50 Hz.

Sur demande, des tensions spéciales sont disponibles dans la plage 24...690 V, 50-60 Hz.

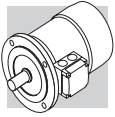

Dati tecnici freni FA

Technical specifications of FA brakes

Technische Daten der Bremsen vom Typ FA

Caractéristiques techniques freins FA

(A62)

Freno Brake Bremse Frein	Coppia frenante Brake torque Bremsmoment Couple de freinage M _b [Nm]	Rilascio Release Ansprechzeit Déblocage t ₁ [ms]	Frenatura Braking Bremsung Freinage t ₂ [ms]	W _{max}			W [MJ]	P _b [VA]
				10 s/h	100 s/h	1000 s/h		
FA 02	3.5	4	20	4500	1400	180	15	60
FA 03	7.5	4	40	7000	1900	230	25	80
FA 04	15	6	60	10000	3100	350	30	110
FA 14								
FA 05	40	8	90	18000	4500	500	50	250
FA 15								
FA 06S	60	16	120	20000	4800	550	70	470
FA 06	75	16	140	29000	7400	800	80	550
FA 07	150	16	180	40000	9300	1000	130	600
FA 08	250	20	200	60000	14000	1500	230	1200

Legenda:

M_b = max coppia frenante statica (±15%)
 t₁ = tempo di rilascio freno
 t₂ = ritardo di frenatura
 W_{max} = energia max per frenata (capacità termica del freno)
 W = energia di frenatura tra due regolazioni successive del traferro
 P_b = potenza assorbita dal freno a 20° (50 Hz)
 s/h = avviamenti orari

N.B.
 I valori di t₁ e t₂ riportati in tabella sono riferiti al freno tarato alla coppia nominale, traferro medio e tensione nominale.

Key:

M_b = max static braking torque (±15%)
 t₁ = brake release time
 t₂ = brake engagement time
 W_{max} = max energy per brake operation (brake thermal capacity)
 W = braking energy between two successive air gap adjustments
 P_b = power drawn by brake at 20° (50 Hz)
 s/h = starts per hour

NOTE
 Values t₁ and t₂ in the table refer to a brake set at rated torque, medium air gap and rated voltage.

Legende:

M_b = statisches max. Bremsmoment (±15%)
 t₁ = Bremsenansprechzeit
 t₂ = Bremsverzögerung
 W_{max} = max. Energie pro Bremsung (Wärmeleistung der Bremse)
 W = Bremsenergie zwischen zwei Einstellungen des Luftspalts
 P_b = bei 20° von der Bremse aufgenommene Leistung (50 Hz)
 s/h = Einschaltungen pro stunde

HINWEIS:
 Die in der Tabelle angegebenen Werte t₁ und t₂ beziehen sich auf eine Bremse, die auf das Nenn Drehmoment, einen mittleren Luftspalt und die Standardspannung eingestellt ist.

Légende:

M_b = couple de freinage statique max (±15%)
 t₁ = temps de déblocage frein
 t₂ = retard de freinage
 W_{max} = énergie max par freinage (capacité thermique du frein)
 W = énergie de freinage entre deux réglages successifs de l'entrefer
 P_b = puissance absorbée par le frein à 20° (50 Hz)
 s/h = démarrages horaires

N.B.
 Les valeurs de t₁ et t₂ indiquées dans le tableau se réfèrent au frein étalonné au couple nominal, entrefer moyen et tension nominale.

Collegamenti freno FA

Per i motori con alimentazione del freno derivata direttamente dall'alimentazione motore i collegamenti alla morsettiera corrispondono a quanto riportato nello schema (A63):

FA brake connections

The diagram (A63) shows the wiring when brake is connected directly to same power supply of the motor:

Abschlüsse - Bremstyp FA

Bei den Motoren mit direkter Bremsspannungsversorgung müssen die Anschlüsse im Klemmenkasten entsprechend den Angaben im Schema (A63) angeschlossen werden:

Raccordements frein FA

Pour les moteurs avec alimentation du frein dérivant directement de l'alimentation moteur, les raccordements à la boîte à bornes correspondent aux indications du schéma (A63) :

(A63)

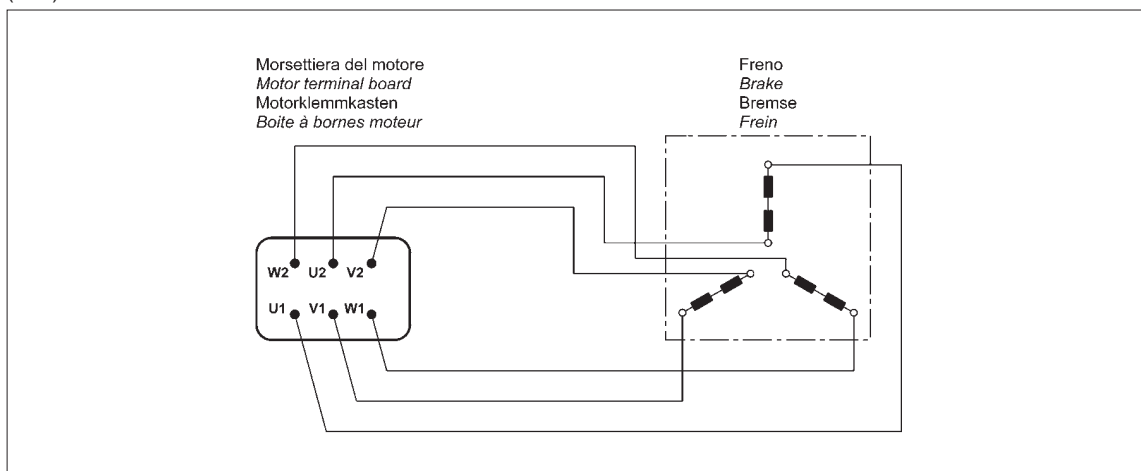

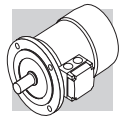

Per i motori a doppia polarità e, quando richiesto, per i motori ad una velocità con alimentazione da linea separata è prevista una morsettiera ausiliaria a 6 morsetti per il collegamento del freno; in questa esecuzione i motori prevedono la scatola coprimorsetti maggiorata. Vedi schema (A64):

Switch-pole motors and, at request, single-pole motors with separate power supply are equipped with an auxiliary terminal board with 6 terminals for brake connection.

In this version, motors feature a larger terminal box. See diagram (A64):

Bei den polumschaltbaren Motoren und, auf Anfrage, auch bei den einpoligen Motoren mit separater Bremsversorgung ist für den Anschluss der Bremse ein Hilfsklemmenkasten mit 6 Klemmen vorgesehen. In diesen Ausführungen haben die Motoren einen größeren Klemmenkasten. Siehe Schema (A64):

Pour les moteurs à double polarité et, lorsque cela est requis, pour les moteurs à une vitesse avec alimentation depuis ligne séparée, une boîte à bornes auxiliaire à 6 bornes est prévue pour le raccordement du frein ; dans cette exécution les moteurs prévoient un couvercle bornier majoré. Voir schéma (A64) :

(A64)

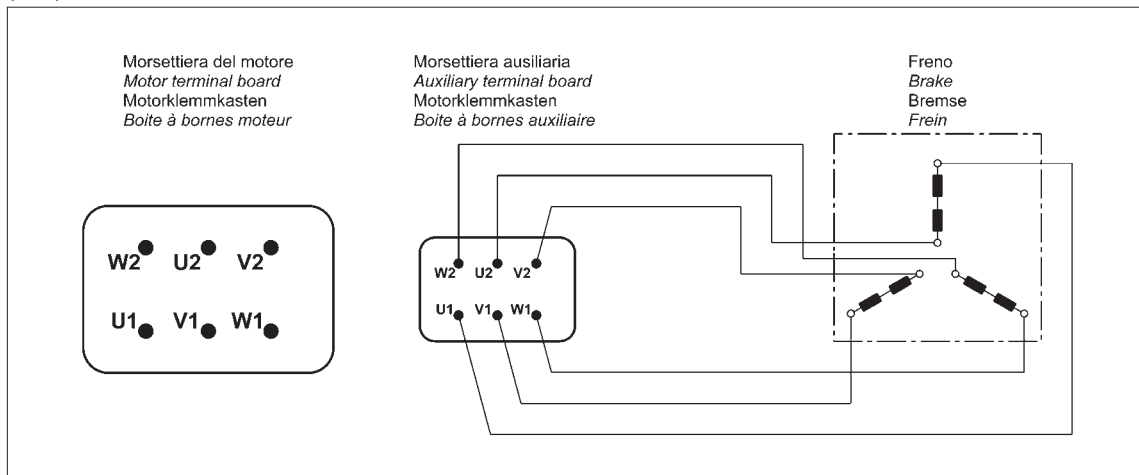

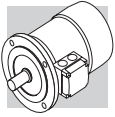

**M8 - MOTORI AUTOFRENANTI
IN C.A., TIPO BN_BA**

**M8 - AC BRAKE MOTORS
TYPE BN_BA**

**M8 - DREHSTROM-BREMS-
MOTOREN MIT WECH-
SELS- TROMBREMSE
VOM TYP BN_BA**

**M8 - MOTEURS FREIN EN C.A.,
TYPE BN_BA**

Grandezze: BN 63 ... BN 132M

Frame sizes: BN 63 ... BN 132M

Baugrößen: BN 63 ... BN 132M

Tailles : BN 63 ... BN 132M

(A65)

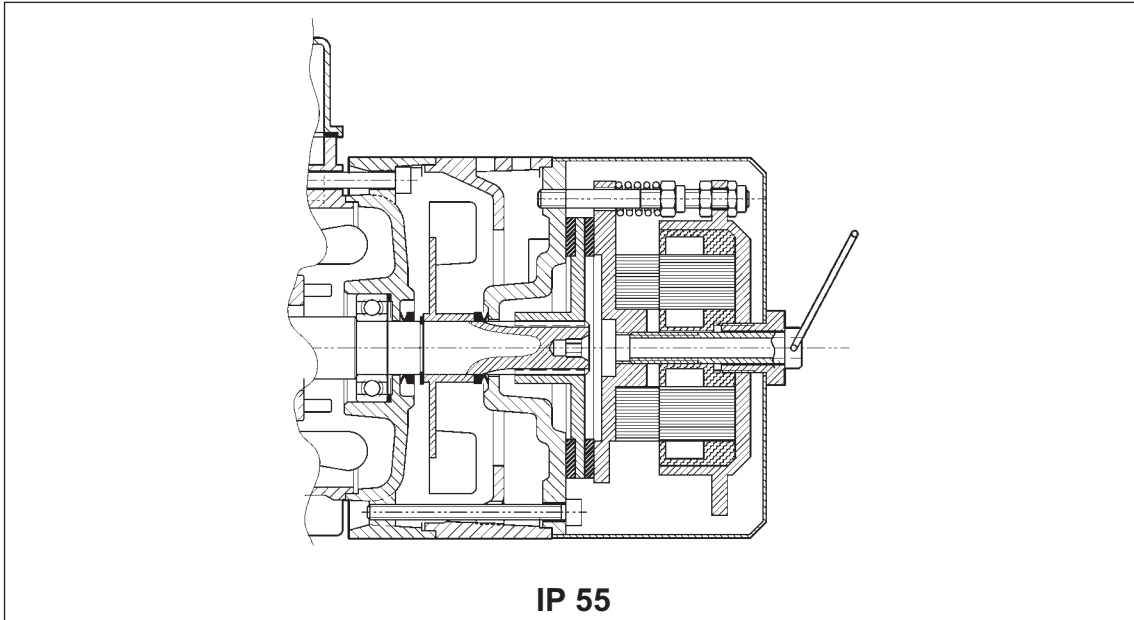

Freno elettromagnetico con alimentazione in **corrente alternata** trifase, fissato con viti allo scudo convogliatore.

Disco freno in acciaio scorrevole assialmente sull'albero motore scanalato (mozzo trascinatore in acciaio calettato sull'albero per grandezza 244).

I motori sono forniti con freno tarato alla massima coppia.

La coppia freno è regolabile con continuità agendo sulle viti di compressione delle molle; il campo di regolazione consentito è $30\% M_{bMAX} < M_b < M_{bMAX}$ (M_{bMAX} è il momento frenante massimo riportato in tab. (A66)). Di serie i motori sono forniti completi di vite per lo sblocco manuale del freno, con mantenimento della posizione di rilascio per consentire la rotazione dell'albero motore.

La vite di sblocco deve essere smontata dopo l'utilizzo per assicurare il corretto funzionamento del freno, ed evitare situazioni potenzialmente pericolose.

Il freno BA, oltre alle elevate caratteristiche dinamiche tipiche dei freni in corrente alternata, presenta una costruzione robusta con energia di frenatura aumentata che lo rendono particolarmente idoneo a servizi pesanti, oltre che in applicazioni dove sono richieste frequenze di manovra elevate e tempi d'intervento molto rapidi.

*Electromagnetic brake operates from three-phase **alternated current** power supply and is bolted onto conveyor shield.*

Steel brake disc slides axially on splined motor shaft (steel drive hub is shrunk onto shaft on frame size 244).

Factory setting is maximum brake torque.

Step less braking torque adjustment by screws which compress the brake springs. Allowed adjustment range is $30\% M_{bMAX} < M_b < M_{bMAX}$ (where M_{bMAX} is maximum braking torque as shown in tab. (A66)).

Motors are supplied complete with manual brake release screw as standard. Screw may be locked in the release position to allow for motor shaft rotation.

The brake release screw must be removed after use to ensure proper brake operation and avoid potentially dangerous conditions.

In addition to the high dynamic characteristics typical of AC brakes, a sturdy design and increased braking energy make the BA brake ideal for heavy-duty applications as well as applications requiring frequent stop/starts and very fast response time.

Elektromagnetische Bremse mit **Drehstromversorgung**, die mittels Schrauben am Motorschild des Motors befestigt ist.

Die Brems Scheibe (Stahl) gleitet axial auf der Rotorwelle (bei Baugröße 244 über einem auf die Welle aufgezogenem Mitnehmer aus Stahl).

Die Motoren werden mit einer auf das maximale Drehmoment des Motors eingestellten Bremse geliefert.

Das Bremsdrehmoment ist durch Betätigen der Federdruckschrauben stufenlos regelbar. Der zulässige Einstellbereich beträgt $30\% M_{bMAX} < M_b < M_{bMAX}$ (M_{bMAX} steht für den max. Bremsmoment, das in der Tab. (A66) angegeben wird).

Die Motoren werden serienmäßig mit einer Schraube zur manuelle Bremslüftung geliefert; die arretierbar ist, um ein Drehen der Motorwelle zu ermöglichen.

Diese Schraube muss im Betrieb des Motors wieder abmontiert werden, damit die korrekte Funktion der Bremse gesichert ist.

Die Bremse vom Typ BA zeichnet sich durch ihre dynamischen Eigenschaften und die robuste Bauweise aus, durch die sie eine erhöhte Bremsenergie abzugeben kann. Diese Bremstypen eignen sich besonders für einen Einsatz unter harten Bedingungen und überall dort, wo häufige Schaltfrequenzen und schnelle Ansprechzeiten gefordert werden.

*Frein électromagnétique avec alimentation en **courant alternatif** triphasé, fixé avec des vis au bouclier.*

Disque frein en acier coulissant de façon axiale sur l'arbre moteur rainuré (moyeu d'entraînement en acier calé sur l'arbre pour la taille 244).

Les moteurs sont fournis avec frein étalonné au couple maximal.

Le couple de freinage est réglable en continu en intervenant sur les vis de compression des ressorts; la plage de réglage autorisé est de $30\% M_{bMAX} < M_b < M_{bMAX}$ (M_{bMAX} étant le couple de freinage maximum indiqué dans le tab. (A66)).

De série, les moteurs sont fournis avec vis de déblocage manuel du frein, avec maintien de la position de relâchement afin de permettre la rotation de l'arbre moteur.

La vis de déblocage doit être démontée après utilisation afin de garantir le fonctionnement correct du frein et d'éviter les situations potentiellement dangereuses.

Le frein BA, outre les caractéristiques dynamiques élevées typiques des freins en courant alternatif, est de fabrication robuste avec énergie de freinage majorée, ce qui le rend particulièrement adapté pour les services difficiles ainsi que pour les applications nécessitant des fréquences de manœuvre élevées et des temps d'intervention très rapides.

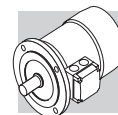

Grado di protezione

È disponibile un'unica esecuzione, con grado di protezione IP55.

Protection class

Only available in protection class IP55.

Schutzart

Es ist eine nur die Ausführung in Schutzklasse IP55 verfügbar.

Degré de protection

Il est disponible en une exécution unique, avec degré de protection IP55.

Alimentazione freno BA

Nei motori a singola polarità l'alimentazione della bobina freno è derivata direttamente dalla morsettiera motore e la tensione del freno quindi coincide con la tensione del motore. In questo caso la tensione del freno può essere omessa dalla designazione

Per i motori a doppia polarità, e per i motori con alimentazione separata del freno, è presente una morsettiera ausiliaria con 6 terminali per il collegamento alla linea del freno. In entrambi i casi il valore di tensione del freno dovrà essere specificato in designazione.

Nella tabella seguente sono riportate le condizioni di alimentazione standard del freno in c.a. per i motori a singola e doppia polarità:

BA brake power supply

In single speed motors, power supply is brought to the brake coil direct from the motor terminal box. As a result, brake voltage and motor voltage are the same. In this case, brake voltage indication may be omitted in the designation.

Switch-pole motors and motors with separate brake power supply feature an auxiliary terminal board with 6 terminals for connection to brake line. In both cases, brake voltage indication in the designation is mandatory. The following table reports standard AC brake power supply ratings for single- and switch-pole motors:

Stromversorgung - Bremstyp BA

Bei den einpoligen Motoren wird die Versorgung der Bremsspule direkt vom Motorklemmenkasten abgezweigt, das bedeutet also, dass die Spannung der Bremse mit der Motorspannung übereinstimmt. In diesem Fall braucht die Bremsenspannung nicht extra angegeben werden.

Für polumschaltbaren Motoren und für eine separate Bremsversorgung ist eine Hilfsklemmenleiste mit 6 Anschlüssen vorgesehen, die einen Anschluss der Bremse ermöglichen. In beiden Fällen muss die Bremsenspannung bei der Bestellung angegeben werden.

In der nachstehenden Tabelle werden für die einpoligen und die polumschaltbaren Motoren die Standardversorgung der Wechselstrombremsen angegeben.

Alimentation frein BA

Sur les moteurs à simple polarité, l'alimentation de la bobine frein dérive directement du bornier moteur, par conséquent, la tension du frein coïncide avec la tension du moteur. Dans ce cas, la tension du frein peut être omise de la désignation.

Pour les moteurs à double polarité et les moteurs avec alimentation séparée du frein, un boîte à bornes auxiliaire avec 6 bornes pour le raccordement au réseau du frein, est présente. Dans les deux cas, la valeur de tension du frein doit être spécifiée dans la désignation.

Le tableau suivant indique les conditions d'alimentation standard du frein en c.a. pour les moteurs à simple et double polarité :

(A65)

motori a singola polarità single-pole motor Einpolige Motoren Moteurs à simple polarité	BN 63 ... BN 132
	230Δ / 400Y V ±10% – 50 Hz
	265Δ / 460Y ±10% - 60 Hz
motori a doppia polarità (alimentazione da linea separata) switch-pole motors (separate power supply line) Polumschaltbare Motoren (separate Versorgung) Moteurs à double polarité (alimentation depuis ligne séparée)	BN 63 ... BN 132
	230Δ / 400Y V ±10% – 50 Hz
	460Y - 60 Hz

Se non diversamente specificato, l'alimentazione standard del freno è 230Δ / 400Y V - 50 Hz.

Unless otherwise specified, standard brake power supply is 230Δ / 400Y V - 50 Hz.

Falls nicht anderweitig angegeben, beträgt die Standardversorgung der Bremse 230Δ / 400Y V - 50 Hz.

Sauf spécification contraire, l'alimentation standard du frein est 230Δ / 400Y V - 50 Hz.

Su richiesta, sono disponibili tensioni speciali, nel campo 24...690 V, 50-60 Hz.

Special voltages in the 24...690 V, 50-60 Hz range are available at request.

Auf Anfrage können Sonderspannungen von 24...690 V, 50-60 Hz geliefert werden.

Sur demande, des tensions spéciales sont disponibles dans la plage 24...690 V, 50-60 Hz.

Dati tecnici freni BA

Nella tabella (A66) sottostante sono riportati i dati tecnici dei freni in c.a., tipo BA.

BA brake technical specifications

The table (A66) below reports the technical specifications for AC brakes type BA.

Technische Daten der Bremsen vom Typ BA

In der nachstehenden Tabelle (A66) werden die technischen Daten der Wechselstrombremsen vom Typ BA angegeben:

Caractéristiques techniques freins BA

Le tableau (A66) ci-dessous indique les caractéristiques techniques des freins en c.a., type BA.

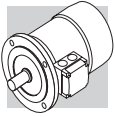

(A66)

Freno Brake Bremsse Frein	Coppia frenante Brake torque Bremsmoment Couple de freinage M_b [Nm]	Rilascio Release Ansprechzeit Déblocage t_1 [ms]	Frenatura Braking Bremsung Freinage t_2 [ms]	W _{max}			W [MJ]	P _b [VA]
				[J]				
				10 s/h	100 s/h	1000 s/h		
BA 60	5	5	20	4000	1500	180	30	60
BA 70	8	6	25	7000	2700	300	60	75
BA 80	18	6	25	10000	3100	350	80	110
BA 90	35	8	35	13000	3600	400	88	185
BA 100	50	8	35	18000	4500	500	112	225
BA 110	75	8	35	28000	6800	750	132	270
BA 140	150	15	60	60000	14000	1500	240	530

Legenda:

M_b = max coppia frenante statica (±15%)

t_1 = tempo di rilascio freno

t_2 = ritardo di frenatura

W_{max} = energia max per frenata (capacità termica del freno)

W = energia di frenatura tra due regolazioni successive del traferro

P_b = potenza assorbita dal freno a 20° (50 Hz)

s/h = avviamenti orari

N.B.

I valori di t_1 e t_2 riportati in tabella sono riferiti al freno tarato alla coppia nominale, traferro medio e tensione nominale.

Key:

M_b = max static braking torque (±15%)

t_1 = brake release time

t_2 = brake engagement time

W_{max} = max energy per brake operation (brake thermal capacity)

W = braking energy between two successive air gap adjustments

P_b = brake power absorption at 20° (50 Hz)

s/h = starts per hour

NOTE

Values t_1 and t_2 in the table refer to a brake set at rated torque, medium air gap and rated voltage.

Legende:

M_b = statisches max. Bremsmoment (±15%)

t_1 = Bremsenansprechzeit

t_2 = Bremsverzögerung

W_{max} = max. Energie pro Bremsung (Wärmeleistung der Bremse)

W = Bremsenergie zwischen zwei Einstellungen des Luftspalts

P_b = bei 20° von der Bremse aufgenommene Leistung (50 Hz)

s/h = Einschaltungen pro stunde

HINWEIS:

Die in der Tabelle angegebenen Werte t_1 und t_2 beziehen sich auf eine Bremse, die auf das Nenn Drehmoment, einen mittleren Luftspalt und die Standardspannung eingestellt ist.

Légende:

M_b = couple de freinage statique max (±15%)

t_1 = temps de déblocage frein

t_2 = retard de freinage

W_{max} = énergie max par freinage (capacité thermique du frein)

W = énergie de freinage entre deux réglages successifs de l'entrefer

P_b = puissance absorbée par le frein à 20° (50 Hz)

s/h = démarrages horaires

N.B.

Les valeurs de t_1 et t_2 indiquées dans le tableau se réfèrent au frein étaloné au couple nominal, entrefer moyen et tension nominale.

Collegamenti freno BA

Per i motori con alimentazione del freno derivata direttamente dall'alimentazione motore i collegamenti alla morsettiera corrispondono a quanto riportato nello schema (A67):

BA brake connections

The diagram (A67) shows the required connections to terminal box when brake is to be connected directly to motor power supply:

Abschlüsse - Bremstyp BA

Bei den Motoren mit direkter Bremsspannungsversorgung müssen die Anschlüsse im Klemmenkasten entsprechend den Angaben im Schema (A67) angeschlossen werden:

Raccordements frein BA

Pour les moteurs avec alimentation du frein dérivant directement de l'alimentation moteur, les raccordements à la boîte à bornes correspondent aux indications du schéma (A67) :

(A67)

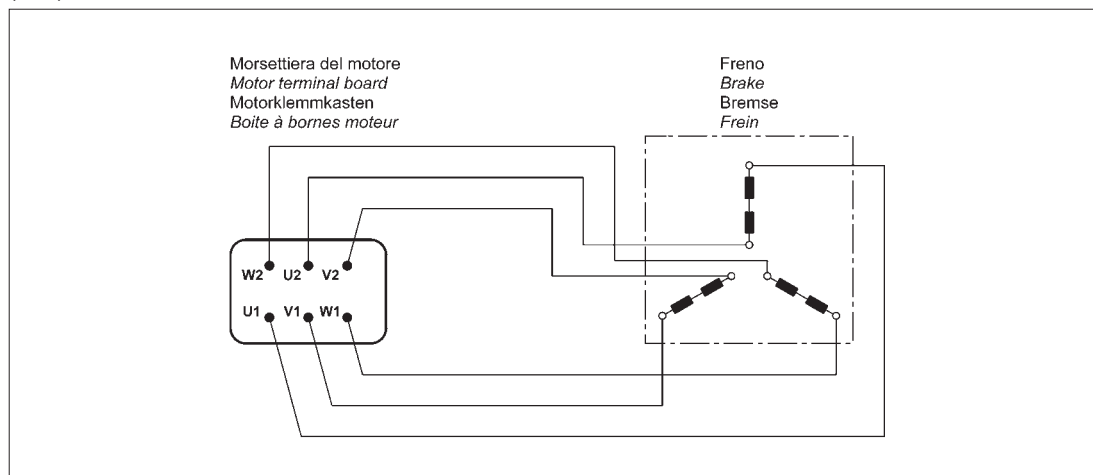

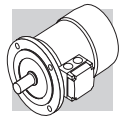

Per i motori a doppia polarità e, quando richiesto, per i motori ad una velocità con alimentazione da linea separata è prevista una morsettiera ausiliaria a 6 morsetti per il collegamento del freno; in questa esecuzione i motori prevedono la scatola coprimorsetti maggiorata. Vedi schema (A68):

Switch-pole motors and, at request, single-pole motors with separate power supply line are equipped with an auxiliary terminal board with 6 terminals for brake connection. In this version, motors feature a larger terminal box. See diagram (A68):

Bei den polumschaltbaren Motoren und, auf Anfrage, auch bei den einpoligen Motoren mit separater Bremsversorgung ist für den Anschluss der Bremse ein Hilfsklemmenkasten mit 6 Klemmen vorgesehen. In diesen Ausführungen haben die Motoren einen größeren Klemmenkasten. Siehe Schema (A68):

Pour les moteurs à double polarité et, lorsque cela est requis, pour les moteurs à une vitesse avec alimentation depuis ligne séparée, une boîte à bornes auxiliaire à 6 bornes est prévue pour le raccordement du frein ; dans cette exécution les moteurs prévoient un couvercle bornier majoré. Voir schéma (A68) :

(A68)

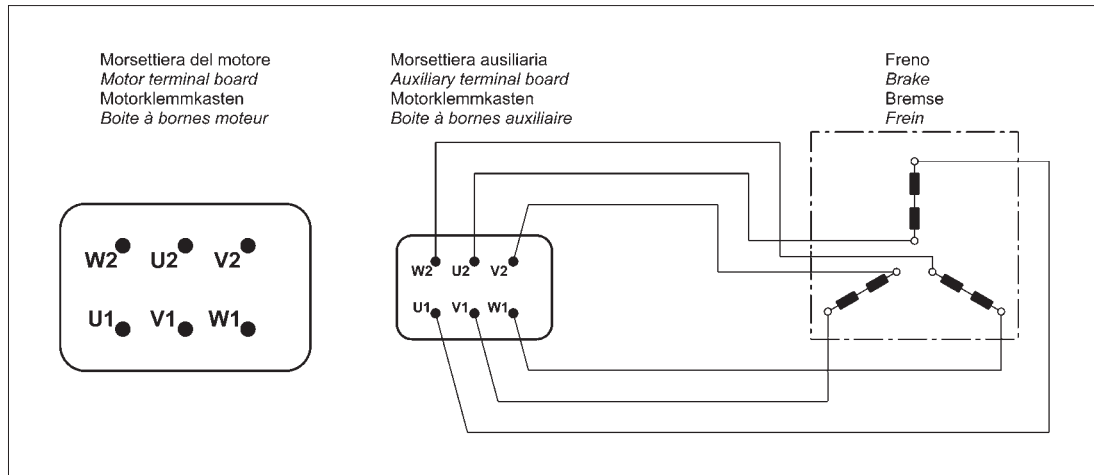

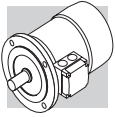

M9 - SISTEMI DI SBLOCCO FRENO

I freni a pressione di molle tipo **FD** e **FA** possono essere dotati opzionalmente di dispositivi per lo sblocco manuale del freno, normalmente utilizzati per condurre interventi di manutenzione sulle parti di macchina, o dell'impianto, comandate dal motore.

M9 - BRAKE RELEASE SYSTEMS

*Spring-applied brakes type **FD** and **FA** may be equipped with optional manual release devices. These are typically used for manually releasing the brake before servicing any machine or plant parts operated by the motor.*

M9 - BREMSLÜFTHEBEL

Die Federdruckbremsen vom Typ **FD** und **FA** können Optional mit Bremslüfthebeln geliefert werden, die ein manuelles Lüften der Bremse ermöglichen. Diese Lüftungseinrichtungen können bei Instandhaltungsarbeiten an vom Motor betriebenen Maschinen- oder Anlagenteilen verwendet werden.

M9 - SYSTEMES DE DEBLOCAGE FREIN

*Les freins à pression de ressorts type **FD** et **FA** peuvent, en option, être dotés de dispositifs de déblocage manuel du frein, normalement utilisés pour effectuer des interventions d'entretien sur les composants de la machine, ou de l'installation commandée par le moteur.*

(A69)

R

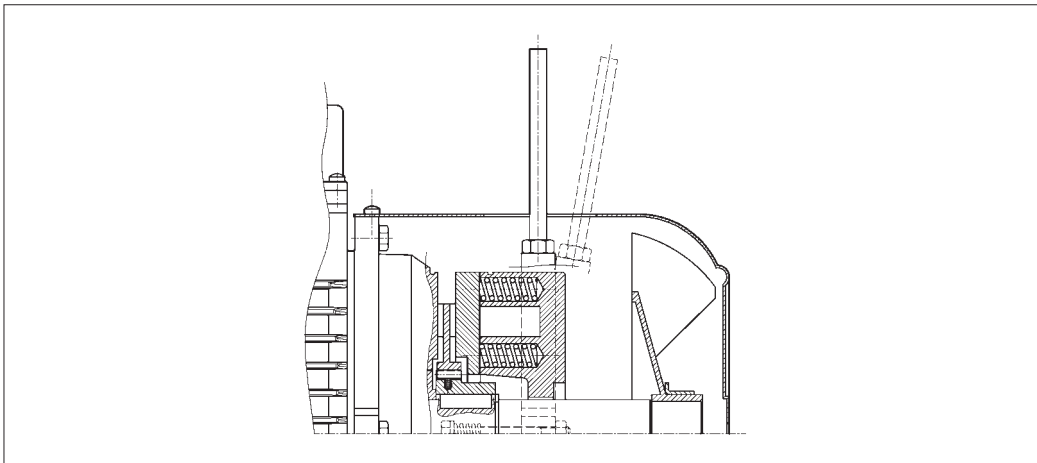

La leva di sblocco è dotata di ritorno automatico, tramite dispositivo a molla.

A return spring brings the release lever back in the original position.

Bremslüfthebel mit automatischer Rückstellung durch Federkraft.

Le levier de déblocage est doté de retour automatique, au moyen d'un dispositif à ressort.

(A70)

RM

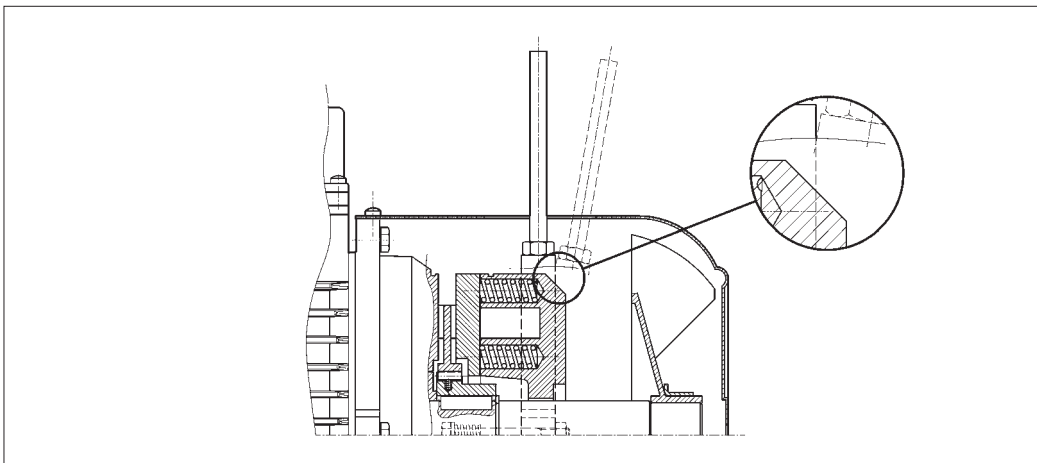

Sui motori tipo **BN_FD** la leva di sblocco può essere temporaneamente bloccata in posizione di rilascio del freno, avvitando la stessa fino ad impegnarne l'estremità in un risalto del corpo del freno.

*On motors type **BN_FD**, if the option **RM** is specified, the release device may be locked in the "release" position by tightening the lever until its end becomes engaged with a brake housing projection.*

Der Bremslüfthebel kann zeitweise in der Bremslüftposition arretiert werden, indem man ihn so lange einschraubt, bis die Bremse arretiert ist. Für die unterschiedlichen Motor-

Levier de déblocage peut être temporairement bloqué en position de déblocage du frein en le vissant jusqu'à engager l'extrémité dans une saillie du corps du frein. La disponibilité des systèmes de

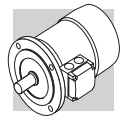

La disponibilità dei sistemi di sblocco freno è diversa per i vari tipi di motore, ed è descritta dalla tabella seguente:

The availability for the various disengagement devices is charted here below:

typen sind ebenso verschiedene Bremslüftsysteme verfügbar, die Sie der folgenden Tabelle entnehmen können:

débloccage du frein est différente en fonction des types de moteur et figure dans le tableau suivant :

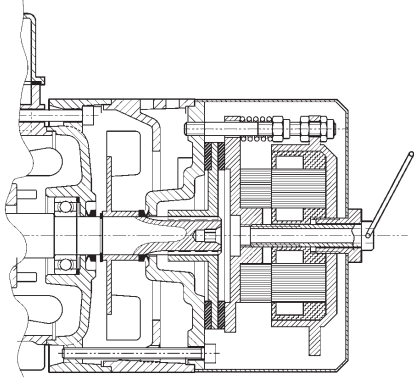
(A71)	R	RM
BN_FD	BN 63...BN 200	2p 63A2 ≤ H ≤ 132M2 4p 63A4 ≤ H ≤ 132MA4 6p 63A6 ≤ H ≤ 132MA6
M_FD	M 05...M 5	M 05...M 4LA
BN_FA	BN 63...BN 180M	
M_FA	M 05...M 5	
BN_BA	 <p>di serie std. supply serienmäßig de série</p>	

Orientamento della leva di sblocco

Release lever orientation

Ausrichtung des Bremslüfthebels

Orientation du levier de déblocage

Per entrambe le opzioni **R** e **RM**, la leva di sblocco del freno viene collocata, se non diversamente specificato, con orientamento di 90° in senso orario, rispetto alla posizione della morsettiera - riferimento **[AB]** nel disegno sottostante. Orientamenti alternativi, tipo **[AA]**, **[AC]** e **[AD]** possono essere richiesti citandone la relativa specifica:

Unless otherwise specified, the release lever is located 90° away from the terminal box – identified by letters **[AB]** in the diagram below – in a clockwise direction on both options **R** and **RM**. Alternative lever positions **[AA]**, **[AC]** and **[AD]** are also possible when the corresponding option is specified:

Bei beiden Optionen, **R** und **RM**, wird der Bremslüfthebel, falls nicht anderweitig festgelegt, um 90° im Uhrzeigersinn zur Position des Klemmenkastens montiert (Position **[AB]** in der nachfolgenden Zeichnung). Andere Positionen: **AA** (0° zum Klemmenkasten), **AC** (180° zum Klemmenkasten) oder **AD** (270° zum Klemmenkasten, im Uhrzeigersinn vom Lüfter aus gesehen) können unter Angabe der entsprechenden Spezifikation bestellt werden:

Pour les deux options **R** et **RM**, le levier de déblocage du frein est positionné, sauf spécification contraire, avec une orientation de 90° dans le sens des aiguilles d'une montre par rapport à la position de la boîte à bornes - référence **[AB]** sur le dessin ci-dessous. Des orientations différentes, type **[AA]**, **[AC]** et **[AD]** peuvent être demandées à condition de préciser la position correspondante :

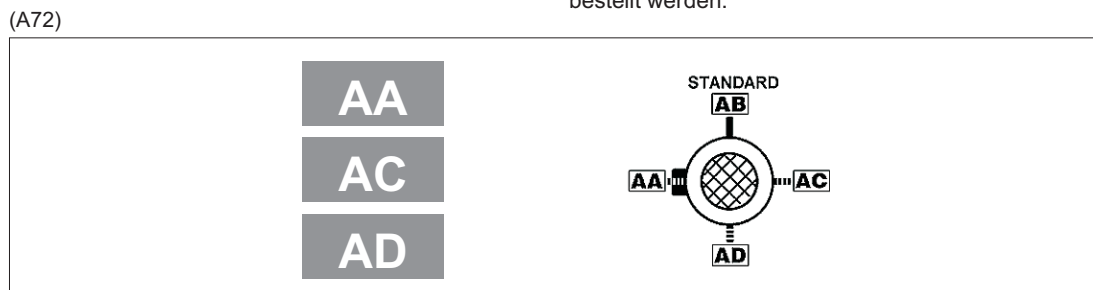

Caratteristiche volani (F1)

Fly-wheel data (F1)

Eigenschaften der Schwunräder (F1)

Caractéristiques volants (F1)

La tabella seguente riporta il peso e l'inerzia aggiuntiva del volani che possono essere richiesti tramite l'opzione F1. Le dimensioni complessive rimangono invariate.

The table below shows values of weight and inertia of flywheel (option F1). Overall dimensions of motors remain unchanged.

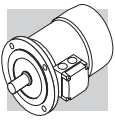

Die folgende Tabelle gibt das Gewicht und das Trägheitsmoment der Zusatzschwunräder an (Option F1). Die Gesamtmaße bleiben unverändert.

Le tableau suivante indique le poids et l'inertie des volants supplémentaires sans variations de l'encombrement moteur.



(A73)

Dati tecnici volano per motori tipo: / Main data for flywheel of motore type: / Eigenschaften der Schwungräder für Motoren typ: / Données volant pour moteurs type: **BN_FD, M_FD**

		Peso volano / Fly-wheel weight Gewicht Schwungrad / Poids volant [Kg]	Inerzia volano / Fly-wheel inertia Trägheitsmoment Schwungrad / Inertie volant [Kgm ²]
BN 63	M05	0.69	0.00063
BN 71	M1	1.13	0.00135
BN 80	M2	1.67	0.00270
BN 90 S - BN 90 L	–	2.51	0.00530
BN 100	M3	3.48	0.00840
BN 112	–	4.82	0.01483
BN 132 S - BN 132 M	M4	6.19	0.02580

M10 - OPZIONI**M10 - OPTIONS****M10 - OPTIONEN****M10 - OPTIONS****Protezioni termiche****Thermal protective devices****Thermische Schutzeinrichtungen****Protections thermiques**

Oltre alla protezione garantita dall'interruttore magnetotermico, i motori possono essere provvisti di sonde termiche incorporate per proteggere l'avvolgimento da eccessivo riscaldamento dovuto a scarsa ventilazione o servizio intermittente.

Questa protezione dovrebbe sempre essere prevista per motori servoventilati (IC416).

In addition to the standard protection provided by the magneto-thermal device, motors can be supplied with built-in thermal probes to protect the winding against overheating caused, by insufficient ventilation or by an intermittent duty.

This additional protection should always be specified for servoventilated motors (IC416).

Abgesehen von den Motorschutzschaltern mit thermischem und elektromagnetischem Auslöser können die Motoren mit integrierten Temperaturfühlern zum Schutz der Wicklung vor Überhitzung z.B. wegen unzureichender Lüftung oder Aussetzbetriebs ausgestattet werden.

Diese Schutzeinrichtung muß bei fremdbelüfteten Motoren stets vorgesehen werden (IC416).

Outre la protection garantie par l'interrupteur magnétothermique, les moteurs peuvent être équipés de sondes thermiques incorporées pour protéger le bobinage contre une surchauffe excessive due par exemple à une ventilation insuffisante ou un service intermittent.

Cette protection devrait toujours être prévue pour les moteurs servoventilés (IC416).

E3**Sonde termiche a termistori****Thermistors****Temperaturfühler und Thermistoren****Sondes thermométriques**

Sono dei semiconduttori che presentano una rapida variazione di resistenza in prossimità della temperatura nominale di intervento (150 °C).

L'andamento della caratteristica $R = f(T)$ è normalizzato dalle Norme DIN 44081, IEC 34-11. Questi sensori presentano il vantaggio di avere ingombri ridotti, un tempo di risposta molto contenuto e, dato che il funzionamento avviene senza contatti, sono completamente esenti da usura.

In genere vengono impiegati termistori a coefficiente di temperatura positivo denominati anche "resistori a conduttore freddo" PTC.

A differenza delle sonde termiche bimetalliche, non possono intervenire direttamente sulle correnti delle bobine di eccitazione e devono pertanto essere collegati ad una speciale unità di controllo (apparecchio di sgancio) da interfacciare alle connessioni esterne.

Con questa protezione vengono inseriti tre PTC, (collegati in serie), nell'avvolgimento con terminali disponibili in morsettiera ausiliaria.

These are semi-conductors having rapid resistance variation when they are close to the rated switch off temperature (150 °C). Variations of the $R = f(T)$ characteristic are specified under DIN 44081, IEC 34-11 Standards.

These elements feature several advantages: compact dimensions, rapid response time and, being contact-free, absolutely no wear.

Positive temperature coefficient thermistors are normally used (also known as PTC "cold conductor resistors").

Contrary to bimetallic thermostats, they cannot directly intervene on currents of energizing coils, and must therefore be connected to a special control unit (triggering apparatus) to be interfaced with the external connections.

Thus protected, three PTCs connected in series are installed in the winding, the terminals of which are located on the auxiliary terminal-board.

Hierbei handelt es sich um Halbleiter, die eine schnelle Änderung des Widerstands in der Nähe der Nennansprechtemperatur (150 °C) zeigen.

Der Verlauf der Kennlinie $R = f(T)$ ist durch die DIN-Normen 44081 und IEC 34-11 festgelegt. Diese Sensoren haben folgende Vorteile: sie weisen geringe Außenmaße und eine äußerst kurze Ansprechzeit auf und sind vollkommen verschleißfrei, da sie berührungslos arbeiten.

Im allgemeinen werden Thermistoren mit positivem Temperaturkoeffizienten verwendet, die auch als "Kaltleiter" (PTC-Widerstände) bezeichnet werden.

Im Unterschied zu Bimetall-Temperaturfühlern können sie nicht direkt auf die Erregungsströme der Spulen wirken, sondern müssen an eine spezielle Steuereinheit (Auslösegerät) angeschlossen werden, die mit den externen Anschlüssen kompatibel ist.

Mit dieser Schutzeinrichtung werden drei in Reihe geschaltete PTC-Widerstände in die Wicklung eingesetzt, deren Endanschlüsse an einer Zusatzklemmleiste verfügbar sind.

Ce sont des semiconducteurs qui présentent une variation rapide de résistance à proximité de la température nominale d'intervention (150 °C).

L'évolution de la caractéristique $R = f(T)$ est défini par les Normes DIN 44081, IEC 34-11.

Ces capteurs présentent l'avantage d'avoir des encombrements réduits, un temps de réponse très bref et, du fait que le fonctionnement a lieu sans contact, il sont exempts d'usure.

En général, on utilise des thermistors à coefficient de température positif dénommés également "résistors à conducteur froid" PTC.

Contrairement aux sondes thermiques bimétalliques, ils ne peuvent intervenir directement sur les courants des bobines d'excitation et doivent par conséquent être reliés à une unité spéciale de contrôle (appareil de déconnexion) à interfacer aux connexions extérieures.

Avec cette protection, trois sondes, (reliées en série), sont insérées dans le bobinage avec extrémités disponibles dans le bornier auxiliaire.

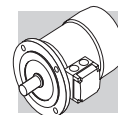

D3

Sonde termiche bimetalliche

Bimetallic thermostates

I protettori di questo tipo contengono all'interno di un involucro un disco bimetallico che, raggiunta la temperatura nominale di intervento (150 °C), commuta i contatti dalla posizione di riposo. Con la diminuzione della temperatura, il disco e i contatti riprendono automaticamente la posizione di riposo. Normalmente si impiegano tre sonde bimetalliche in serie con contatti normalmente chiusi e terminali disponibili in una morsettiera ausiliaria.

These types of protective devices house a bimetal disk. When the rated switch off temperature (150 °C) is reached, the disk switches the contacts from their initial rest position. As temperature falls, the disk and the contacts automatically return to rest position. Three bimetallic thermostates connected in series are usually employed, with normally closed contacts. The terminals are located on an auxiliary terminal-board.

Bimetall-Temperaturfühler

Diese Schutzeinrichtungen bestehen aus einer Kapsel, in der sich eine Bimetallscheibe befindet, die bei Erreichen der Nennansprechtemperatur (150 °C) anspricht. Nach Absenkung der Temperatur geht der Schaltkontakt automatisch in Ruhestellung zurück. Normalerweise werden drei in Reihe geschaltete Bimetallfühler mit Öffnern verwendet, deren Endverschlüsse an einer Zusatzklemmleiste verfügbar sind.

Sondes thermiqes bimétalliques

Les protecteurs de ce type contiennent, dans une enveloppe interne, un disque bimétallique qui, lorsque la température nominale d'intervention (150 °C) est atteinte, commute les contacts de la position de repos. Avec la diminution de la température, le disque et les contacts reprennent automatiquement la position de repos. Normalement, on utilise trois sondes bimétalliques en série avec contacts normalement fermés et extrémités disponibles dans un bornier auxiliaire.

H1

Riscaldatori anticondensa

Anti-condensation heaters

I motori funzionanti in ambienti molto umidi e/o in presenza di forti escursioni termiche, possono essere equipaggiati con una resistenza anti-condensa. L'alimentazione monofase è prevista da morsettiera ausiliaria posta nella scatola principale. Le potenze assorbite dalla resistenza elettrica sono elencate qui di seguito:

Where an application involves high humidity or extreme temperature fluctuation, motors may be equipped with an anti-condensate heater. A single-phase power supply is available in the auxiliary terminal board inside the main terminal box. Values for the absorbed power are listed here below:



Wicklungsheizung

Die Motoren, die in besonders feuchten Umgebungen und/oder unter starken Temperaturschwankungen eingesetzt werden, können mit einem Heizelement als Kondenswasserschutz ausgestattet werden. Die einphasige Versorgung erfolgt über eine Zusatzklemmleiste, die sich im Klemmenkasten befindet. Werte fuer die Leistungsaufnahme sind in folgender Tabelle aufgeführt.

Rechauffeurs anticondensation

Les moteurs fonctionnant dans des milieux très humides et/ou en présence de fortes plages thermiques peuvent être équipés d'une résistance anticondensation. L'alimentation monophasée est prévue par l'intermédiaire d'une boîte à bornes auxiliaire située dans la boîte principale. Les puissances absorbées sont indiqués de suite :

(A74)

		H1
		1~ 230V ± 10% P [W]
BN 56...BN 80	M0...M2	10
BN 90...BN 160MR	M3 - M4	25
BN 160M...BN 180M	M5	50
BN 180L...BN 200L	—	50

Importante!
Durante il funzionamento del motore la resistenza anticondensa non deve mai essere inserita.

Warning!
Always remove power supply to the anti-condensate heater before operating the motor.

Warnung!
Während des Motorbetriebs darf die Wicklungsheizung nie gespeist werden.

Avertissement!
Durant le fontionnement du moteur, la résistance anticondensation ne doit jamais être alimentée.

PS

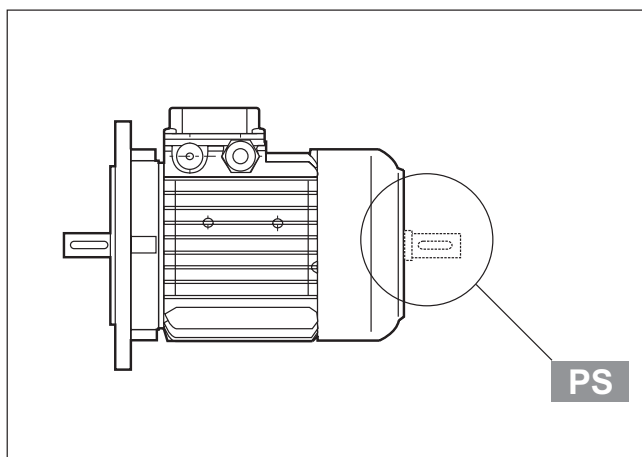

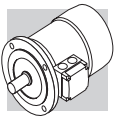

Seconda estremità d'albero

L'opzione esclude le varianti RC, TC, U1, U2, EN1, EN2, EN3 – non applicabile ai motori con freno tipo BA. Le dimensioni sono reperibili nelle tavole dimensionali dei motori.

Second shaft extension

This option is not compatible with variants RC, TC, U1, U2, EN1, EN2, EN3 – and is not feasible on motors equipped with BA brake. For shaft dimensions please see motor dimensions tables.

Zweites Wellenende

Diese Option schließt die Optionen RC, TC, U1, U2, EN1, EN2, EN3 aus – sie kann nicht außerdem nicht an Motoren, die mit einer Bremse vom Typ BA ausgestattet sind, angebaut werden. Die entsprechenden Maße können den Maßtabellen der Motoren entnommen werden.

Arbre à double extrémité

L'option exclut les variantes RC, TC, U1, U2, EN1, EN2, EN3 – non applicables aux moteurs avec frein type BA. Les dimensions figurent sur les planches de dimensions des moteurs.

AL

AR

Dispositivo antiritorno

Nelle applicazioni dove è necessario impedire la rotazione inversa del motore dovuta all'azione del carico, è possibile impiegare motori provvisti di un dispositivo antiritorno (disponibile solo sulla serie M). Questo dispositivo, pur consentendo la libera rotazione nel senso di marcia, interviene istantaneamente in caso di mancanza di alimentazione bloccando la rotazione dell'albero nel senso inverso.

Il dispositivo antiritorno è lubrificato a vita con grasso specifico per questa applicazione.

In fase di ordine dovrà essere indicato chiaramente il senso di marcia previsto.

In nessun caso il dispositivo antiritorno dovrà essere utilizzato per impedire la rotazione inversa nel caso di collegamento elettrico errato.

Nella tabella (A75) sono indicate le coppie nominale e massima di bloccaggio attribuite ai dispositivi antiritorno utilizzati, mentre la raffigurazione schematica del dispositivo è inserita nella tabella (A76).

Le dimensioni sono le stesse del motore autofrenante.

Il senso di rotazione libera è descritto nel paragrafo 19 (opzioni motori).

Backstop device

For applications where backdriving must be avoided, motors equipped with an anti run-back device can be used (available for the M series only). While allowing rotation in the direction required, this device operates instantaneously in case of a power failure, preventing the shaft from running back. The anti run-back device is life lubricated with special grease for this specific application. When ordering, customers should indicate the required rotation direction, AL or AR. Never use the anti run-back device to prevent reverse rotation caused by faulty electrical connection.

Table (A75) shows rated and maximum locking torques for the anti run-back devices. A diagram of the device can be seen in Table (A76). Overall dimensions are same as the corresponding brake motor.

The direction of free rotation is specified in section 19 (motor options).

Rücklaufsperr

Für Anwendungen, bei denen ein durch die Last verursachtes Rücklaufen des Motors verhindert werden soll, können Motoren installiert werden, die über eine Rücklaufsperr verfügen (nur bei Serie M verfügbar).

Diese Vorrichtung, die eine völlig unbehinderte Drehung des Motors in Laufrichtung gestattet, greift sofort ein, wenn die Spannung fehlt, und verhindert die Drehung der Welle in die Gegenrichtung.

Die Rücklaufsperr verfügt über eine Dauer - Schmierung mit einem speziell für diese Anwendung geeigneten Fett.

Bei der Bestellung muß die vorgesehene Drehrichtung des Motors genau angegeben werden. Die Rücklaufsperr darf keinesfalls verwendet werden, um im Falle eines fehlerhaften elektrischen Anschlusses die Drehung in die Gegenrichtung zu verhindern.

In Tabelle (A75) sind die Nenndrehmomente und Höchst Drehmomente für die verwendeten Rücklaufsperr angegeben; Abbildung (A76) zeigt eine schematische Darstellung der Vorrichtung. Die abmessungen sind ähnlich denen der Bremsmotoren.

Im Abschnitt 19 (Motoroptionen) wird die freie Drehrichtung eingehend beschrieben.

Dispositif anti-retour

Pour les applications où il est nécessaire d'empêcher la rotation inverse du moteur à cause de l'action de la charge, il est possible d'utiliser des moteurs dotés d'un dispositif anti-retour (disponible seulement sur la série M). Ce dispositif, bien que permettant la libre rotation dans le sens de marche, intervient instantanément en cas de manque d'alimentation en bloquant la rotation de l'arbre dans le sens inverse. Le dispositif anti-retour est lubrifié à vie avec une graisse spécifique pour cette application. En phase de commande, il faudra indiquer clairement le sens de marche prévu. En aucun cas, le dispositif anti-retour ne devra être utilisé pour empêcher la rotation inverse en cas de branchement électrique erroné.

Le tableau (A75) indique le couple nominal et le couple maximum de blocage attribués aux dispositifs anti-retour utilisés alors que la représentation schématique du dispositif se trouve dans le tableau (A76). Les dimensions sont le même du moteur frein.

Le sens de rotation libre est décrit au paragraphe 19 (options moteurs).

(A75)

	Coppia nominale di bloccaggio <i>Rated locking torque</i> Nenndrehmoment der Sperre <i>Couple nominal de blocage</i>	Coppia max. di bloccaggio <i>Max. locking torque</i> Max. Drehmoment der Sperre <i>Couple maxi. de blocage</i>	Velocità di distacco <i>Release speed</i> Ausrückgeschwindigkeit <i>Vitesse de décollement</i>
	[Nm]	[Nm]	[min ⁻¹]
M1	6	10	750
M2	16	27	650
M3	54	92	520
M4	110	205	430

(A76)

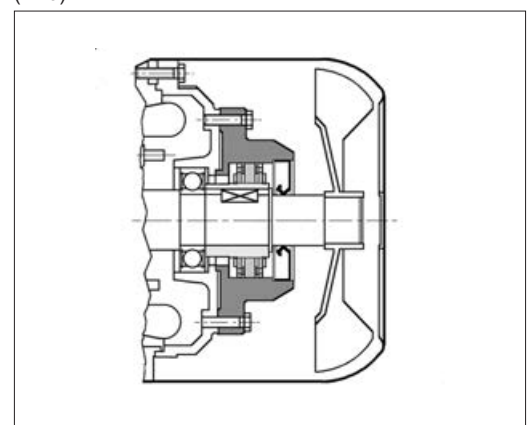

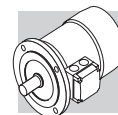

Ventilazione

I motori sono raffreddati mediante ventilazione esterna (IC 411 secondo CEI EN 60034-6) e sono provvisti di ventola radiale in plastica, funzionante in entrambi i versi di rotazione.

L'installazione dovrà assicurare una distanza minima della calotta copriventola dalla parete più vicina, in modo da non creare impedimento alla circolazione dell'aria, oltre che permettere l'esecuzione della manutenzione ordinaria del motore e, se presente, del freno.

Su richiesta, a partire dalle grandezze BN 71, oppure M1, i motori possono essere forniti con ventilazione forzata ad alimentazione indipendente. Il raffreddamento è realizzato per mezzo di un ventilatore assiale con alimentazione indipendente, montato sulla calotta copriventola (metodo di raffreddamento IC 416).

Questa esecuzione è utilizzata in caso di alimentazione del motore tramite inverter allo scopo di estendere il campo di funzionamento a coppia costante anche a bassa velocità, o quando per lo stesso sono richieste elevate frequenze di avviamento.

Da questa opzione sono esclusi i motori autofrenanti tipo BN_BA e tutti i motori con doppia sporgenza d'albero (opzione PS).

Ventilation

Motors are cooled through outer air blow (IC 411 according to CEI EN 60034-6) and are equipped with a plastic radial fan, which operates in both directions.

Ensure that fan cover is installed at a suitable distance from the closest wall so to allow air circulation and servicing of motor and brake, if fitted.

On request, motors can be supplied with independently power-supplied forced ventilation system starting from BN 71 or M1 size.

Motor is cooled by an axial fan with independent power supply and fitted on the fan cover (IC 416 cooling system).

This version is used in case of motor driven by inverter so that steady torque operation is possible even at low speed or when high starting frequencies are needed.

Brake motors of BN_BA type and all motors with rear shaft projection (PS option) are excluded.

Belüftung

Die Motoren werden mittels Fremdbelüftung gekühlt (IC 411 gemäß CEI EN 60034-6) und sind mit einem Radiallüfterrad aus Kunststoff ausgestattet, das in beide Richtungen dreht.

Die Installation muss zwischen Lüfterradkappe und der nächstliegenden Wand einen Mindestabstand berücksichtigen, so dass der Luftumlauf nicht behindert werden kann. Dieser Abstand ist jedoch ebenso für die regelmäßige Instandhaltung des Motors und, falls vorhanden, der Bremse erforderlich.

Ab der Baugröße BN 71 oder M1 können die Motoren auf Anfrage mit einer unabhängig gespeisten Zwangsbelüftung geliefert werden. Die Kühlung erfolgt hierdurch einen unabhängig gespeisten Axialventilator, der auf die Lüfterradkappe (Kühlmethode IC 416) montiert wird.

Diese Ausführung wird im Fall eines über einen Frequenzumrichter versorgten Motor verwendet, so dass der Betriebsbereich bei konstantem Drehmoment auch auf die niedrige Drehzahl ausgedehnt wird, oder im Fall von hohen Anlauffrequenzen.

Von dieser Option ausgeschlossen sind die Bremsmotoren BN_BA und Motoren mit beidseitig herausragender Welle (Option PS).

Ventilation

Les moteurs sont refroidis par ventilation externe (IC 411 selon CEI EN 60034-6) et sont équipés de ventilateur radial en plastique fonctionnant dans les deux sens de rotation.



L'installation doit garantir une distance minimum de la calotte cache-ventilateur par rapport au mur le plus proche de façon à ne pas créer d'empêchement à la circulation de l'air ainsi que pour permettre les interventions d'entretien ordinaire du moteur et, si présent, du frein.

Sur demande, à partir de la taille BN 71, ou M1, les moteurs peuvent être fournis avec ventilation forcée à alimentation indépendante. Le refroidissement est réalisé au moyen d'un ventilateur axial avec alimentation indépendante monté sur la calotte cache-ventilateur (méthode de refroidissement IC 416).

Cette exécution est utilisée en cas d'alimentation du moteur par variateur dans le but d'étendre aussi la plage de fonctionnement à couple constant aux faibles vitesses ou lorsque des fréquences de démarrage élevées sont nécessaire à celui-ci.

Les moteurs frein type BN_BA et les moteurs avec arbre sortant des deux côtés (option PS) SP sont exclus de cette option.

(A77)

Dati di alimentazione / Power supply / Daten der Stromversorgung / Données d'alimentation					
		V a.c. ± 10%	Hz	P [W]	I [A]
BN 71	M1	1~ 230	50 / 60	22	0.12
BN 80	M2			22	0.12
BN 90	—			40	0.30
BN 100 (*)	M3			50	0.25
BN 112	—	3~ 230 Δ / 400Y	50	50	0.26 / 0.15
BN 132S	M4S			110	0.38 / 0.22
BN 132M...BN 160MR	M4L				
BN 160...BN 180M	M5		50	180	1.25 / 0.72

Per la variante sono disponibili due esecuzioni alternative, denominate **U1** e **U2**, aventi lo stesso ingombro in senso longitudinale. Per entrambe le esecuzioni, la maggiore lunghezza della calotta copriventola (ΔL) è riportata nella tabella che segue. Dimensioni complessive ricavabili dalle tavole dimensionali dei motori.



This variant has two different models, called **U1** and **U2**, having the same longitudinal size. Longer side of fan cover (ΔL) is specified for both models in the table below. Overall dimension can be reckoned from motor size table.

Für die Varianten sind als Alternative zwei Ausführungen verfügbar: **U1** und **U2** mit dem gleichen Längsmaßen. Für beide Ausführungen wird die Verlängerung der Lüfterradkappe (ΔL) in der nachstehenden Tabelle wiedergegeben. Gesamtmaße können den Tabellen entnommen werden, in denen die Motormaße angegeben werden.

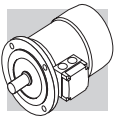
Pour la variante sont disponibles deux exécutions alternatives, dénommées **U1** et **U2**, ayant le même encombrement dans le sens longitudinal. Pour les deux exécutions, la majoration de la longueur de la calotte cache-ventilateur (ΔL) est indiquée dans le tableau suivant. Dimensions totales à calculer d'après les planches de dimensions des moteurs.



(A78)

Tabella maggiorazione lunghezze motore / Extra length for servoveilated motors Tabelle - Motorverlängerung / Tableau majoration longueurs moteur			
		ΔL_1	ΔL_2
BN 71	M1	93	32
BN 80	M2	127	55
BN 90	—	131	48
BN 100	M3	119	28
BN 112	—	130	31
BN 132S	M4S	161	51
BN 132M	M4L	161	51

ΔL_1 = variazione dimensionale rispetto alla quota LB del motore standard corrispondente

ΔL_1 = extra length to LB value of corresponding standard motor

ΔL_1 = Maßänderung gegenüber Maß LB des entsprechenden Standardmotors

ΔL_1 = variation de dimension par rapport à la cote LB du moteur standard correspondant

ΔL_2 = variazione dimensionale rispetto alla quota LB del motore autofrenante corrispondente

ΔL_2 = extra length to LB value of corresponding brake motor

ΔL_2 = Maßänderung gegenüber Maß LB des entsprechenden Bremsmotors

ΔL_2 = variation de dimension par rapport à la cote LB du moteur frein correspondant

U1



Terminali di alimentazione del ventilatore in scatola morsetti separata.

Nei motori autofrenanti grandezza BN 71...BN 160MR, con variante **U1**, la leva di sblocco non è collocabile nella posizione AA. L'opzione non è disponibile per i motori conformi alle norme CSA e UL (opzione CUS).

Fan wiring terminals are housed in a separate terminal box.

*In brake motors of size BN 71...BN 160MR, with **U1** model, the release lever cannot be positioned to AA.*

The option is not applicable to motors compliant with the CSA and UL norms (option CUS).

Versorgungsanschlüsse des Ventilators im Zusatzklemmenkasten.

Bei den Bremsmotoren in der Baugröße BN 71...BN 160MR, mit Variante **U1** kann der Bremslösehebel nicht in der Position AA. Die Option ist nicht anwendbar für die Motoren entsprechend den Normen CSA und UL (Option CUS).

Bornes d'alimentation du ventilateur dans un bornier séparé.

*Pour les moteurs frein taille BN 71...BN 160MR, avec variante **U1**, le levier de déblocage ne peut être installé en position AA. L'option n'est pas disponible pour les moteurs conformes aux normes CSA et UL (option CUS).*

U2



I terminali del ventilatore sono collocati nella scatola morsetti-riera principale del motore.

L'opzione U2 non è applicabile ai motori da BN 160 a BN 200L, con eccezione dei motori BN 160MR, per i quali l'opzione è disponibile e ai motori con opzione CUS (conformi alle norme CSA e UL).

Fan terminals are wired in the motor terminal box.

The U2 option does not apply to motors BN 160 through BN 200L, with the only exception of motor BN 160MR for which the option is available instead and to motors with option CUS (compliant to norms CSA and UL).



Versorgungsanschlüsse des Ventilators befinden sich im Hauptklemmenkasten des Motors.

Die Option U2 ist nicht anwendbar bei den Motoren BN160M...BN200L, außer den Motoren BN160MR wofür die Option verfügbar ist, und bei den Motoren mit der CUS-Option (entsprechend den Normen CSA und UL).

Bornes d'alimentation du ventilateur dans le bornier principal du moteur.

L'option n'est pas applicable aux moteurs BN 160...BN 200L, sauf pour les moteurs BN 160MR, pour lesquels l'option est disponible et aux moteurs avec l'option CUS (conforme aux normes CSA et UL).

(A79)

(*)			V a.c. \pm 10%	Hz	P [W]	I [A]
	BN 100_U2	M3	3~ 230 Δ / 400Y	50 / 60	40	0.12 / 0.09

RC

Tettuccio parapigioggia

Il dispositivo parapigioggia, che è raccomandato quando il motore è montato verticalmente con l'albero verso il basso, serve a proteggere il motore stesso dall'ingresso di corpi solidi e dallo stillicidio.

Drip cover

The drip cover protects the motor from dripping and avoids the ingress of solid bodies. It is recommended when motor is installed in a vertical position with the shaft downwards.

Schutzdach

Das Schutzdach, dessen Montage dann empfohlen wird, wenn der Motor senkrecht mit einer nach unten gerichteten Welle ausgerichtet wird, dient dem Schutz des Motors vor einem Eindringen von festen Fremdkörpern und Tropfwasser.

Capot de protection anti-pluie

Le capot de protection anti-pluie est recommandé lorsque le moteur est monté verticalement avec l'arbre vers le bas, il sert à protéger le moteur contre l'introduction de corps solides et le suintement.

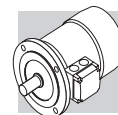



Le dimensioni aggiuntive sono indicate nella tabella (A80). Il tettuccio esclude le varianti PS, EN1, EN2, EN3 e non è applicabile ai motori con freno tipo BA

Relevant dimensions are indicated in the table (A80). The drip cover is not compatible with variants PS, EN1, EN2, EN3 and will not fit motors equipped with a BA brake.

Die Maßerweiterungen werden in der Tabelle (A80) angegeben. Das Schutzdach schließt die Möglichkeit der Varianten PS, EN1, EN2, EN3 und kann bei Motoren mit dem Bremstyp BA nicht montiert werden.

Les dimensions à ajouter sont indiquées dans le tableau (A80). Le capot antipluie exclue les variantes PS, EN1, EN2, EN3 et n'est pas applicable aux moteurs avec frein type BA.

(A80)

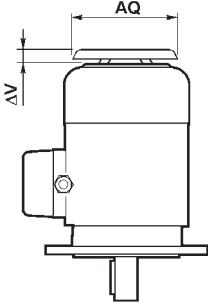
		AQ	ΔV	
BN 63	M05	118	24	
BN 71	M1	134	27	
BN 80	M2	152	25	
BN 90	—	168	30	
BN 100	M3	190	28	
BN 112	—	211	32	
BN 132...BN 160MR	M4	254	32	
BN 160M...BN 180M	M5	302	36	
BN 180L...BN 200L	—	340	36	

TC

Tettuccio tessile

La variante del tettuccio tipo TC è da specificare quando il motore è installato in ambienti dell'industria tessile, dove sono presenti filamenti che potrebbero ostruire la griglia del copriventola, impedendo il regolare flusso dell'aria di raffreddamento. L'opzione esclude le varianti EN1, EN2, EN3 e non è applicabile ai motori con freno tipo BA. L'ingombro complessivo è lo stesso del tettuccio tipo RC.

Textile canopy

Option TC is a cover variant for textile industry environments, where lint may obstruct the fan grid and prevent a regular flow of cooling air. This option is not compatible with variants EN1, EN2, EN3 and will not fit motors equipped with a BA brake. Overall dimensions are the same as drip cover type RC.

Schutzdach

Die Variante des Schutzdachs vom Typ TC muss dann spezifiziert werden, wenn der Motor in Bereichen der Textilindustrie installiert wird, in denen Stofffusseln das Lüfterradgitter verstopfen und so einen regulären Kühlluftfluss verhindern könnten. Diese Option schließt die Möglichkeit der Varianten EN1, EN2, EN3 aus und kann bei Motoren mit einer Bremse vom Typ BA nicht appliziert werden. Die Gesamtmaße entsprechen denen des Schutzdachs vom Typ RC.

Capot textile

La variante del capot type TC est à spécifier lorsque le moteur est installé dans des sites de l'industrie textile, où sont présents des filaments qui pourraient obstruer la grille du cache-ventilateur et empêcher le flux régulier de l'air de refroidissement. L'option exclue les variantes EN1, EN2, EN3 et n'est pas applicable aux moteurs avec frein type BA. L'encombrement total est identique à celui du capot type RC.

Dispositivi di retroazione

I motori possono essere dotati di tre diversi tipi di encoder, qui di seguito descritti. Il montaggio dell'encoder esclude le esecuzioni con doppia estremità d'albero (PS) e tettuccio di protezione (RC, TC). Il dispositivo non è applicabile ai motori dotati del freno im c.a., tipo BA.

Feedback units

Motors may be combined with three different types of encoders to achieve feedback circuits. Configurations with double-extended shaft (PS) and rain canopy (RC, TC) are not compatible with encoder installation. Also not compatible are motors equipped with a.c. brakes, type BA.

Geber-anschluß

Die Motoren können mit drei unterschiedlichen Encodertypen ausgestattet werden. Nachstehend finden Sie die entsprechenden Beschreibungen. Die Montage des Encoders schließt die Version mit zweitem Wellenende (PS) und Schutzdach (RC, TC) aus. Die Vorrichtung kann an Motoren mit Bremse vom Typ BA nicht angebaut werden.

Dispositifs de retroaction

Pour moteurs peuvent être dotés de trois types de codeurs différents, décrits ci-après. Le montage du codeur exclu les exécutions avec arbre à double extrémité (PS) et le capot de protection (RC, TC). Le dispositif n'est pas applicable aux moteurs avec frein en c.a., type BA.

EN1

Encoder incrementale, $V_{IN}=5V$, uscita line-driver RS 422.

Incremental encoder, $V_{IN}=5V$, line-driver output RS 422.

Inkremental-Encoder, $V_{IN}=5V$, Ausgang „line-driver“ RS 422.

Codeur incrémental, $V_{IN}=5V$, sortie line-driver RS 422.

EN2

Encoder incrementale, $V_{IN}=10-30V$, uscita line driver RS 422.

Incremental encoder, $V_{IN}=10-30V$, line-driver output RS 422.

Inkremental-Encoder, $V_{IN}=10-30V$, Ausgang „line driver“ RS 422.

Codeur incrémental, $V_{IN}=10-30V$, sortie line-driver RS 422.

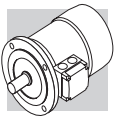

EN3

Encoder incrementale, $V_{IN}=12-30$ V, uscita push-pull 12-30 V

Incremental encoder, $V_{IN}=12-30$ V, push-pull output 12-30 V

Inkremental-Encoder, $V_{IN}=12-30$ V, Ausgang „push-pull“ 12-30 V

Codeur incrémental, $V_{IN}=12-30$ V, sortie push-pull 12-30 V

(A81)

	EN1	EN2	EN3
interfaccia / Interface Schnittstelle / interface	RS 422	RS 422	push-pull
tensione alimentazione / Power supply voltage Versorgungsspannung / tension d'alimentation	[V] 4...6	10...30	12...30
tensione di uscita / Output voltage Ausgangsspannung / tension de sortie	[V] 5	5	12...30
corrente di esercizio senza carico / No-load operating current Betriebsstrom ohne Belastung / courant d'utilisation sans charge	[mA] 120	100	100
n° di impulsi per giro / No. of pulses per revolution Impulse pro Drehung / nbre d'impulsions par tour	1024		
n° segnali / No. of signals Signale / nbre de signaux	6 (A, B, C + segnali invertiti / inverted signals invertierte Signale / signaux inversés)		
max. frequenza di uscita / Max. output frequency Max. Ausgangsfrequenz / fréquence max. de sortie	[kHz]	600	
max. velocità / Max. speed Max. Drehzahl / vitesse max.	[min ⁻¹]	6000 (9000 min ⁻¹) x 10s	
campo di temperatura / Temperature range Temperaturbereich / plage de température	[°C]	-30...+100	
grado di protezione / Protection class Schutzgrad / degré de protection	IP 65		

EN1, EN2, EN3	
BN 63...BN 200L	M05...M5
BN 63_FD...BN 200L_FD	M05_FD...M5_FD
BN 63_FA...BN 200L_FA	M05_FA...M5_FA

EN_ + U1		
		L3
BN 160M...BN 180M	M5	72
BN 180L...BN 200L	-	82
BN 160M_FD...BN 180M_FD	M5_FD	35
BN 180L_FD...BN 200L_FD	-	41

Se l'opzione EN_ è richiesta per motori di grandezza BN71...BN160MR e M1...M4, contemporaneamente all'opzione U1/U2, le variazioni dimensionali coincidono con quelle dell'opzione U1/U2.

If the encoder device (options EN1, EN2, EN3) is specified on motors BN71...BN160MR and M1...M4, along with the independent fan cooling (options U1, U2), the extra length of motor is coincident with that of the correspondent U1 and U2 execution.





Wenn der Encoder (Optionen EN1, EN2, EN3) für Motoren der Baugrößen BN71...BN160MR und M1...M4 zusammen mit Fremd Lüftung (Optionen U1, U2) ausgelegt ist, stimmen die Maßänderungen des Motors mit jenen der entsprechenden Ausführungen U1 und U2 überein.

Si un codeur (option EN1, EN2, EN3) est nécessaire sur les moteurs de tailles BN71...BN160MR et M1...M4, en association avec la ventilation forcée (options U1, U2), la variation de dimensions du moteur coïncide avec celle des exécutions U1 et U2 correspondantes.





2 P

3000 min⁻¹ - S1

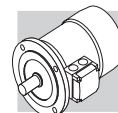
50 Hz

Ph	kW		n min ⁻¹	Mn Nm	IE1	η (100%) %	η (75%) %	η (50%) %	cos φ	In A	Is In	Ms Mn	Ma Mn	Jm x 10 ⁻⁴ kgm ²	IM B5 	freno c.c. / d.c. brake G.S.-bremse / frein c.c.						freno c.a. / a.c. brake W.S.-bremse / frein c.a.													
																Mod.	Mb Nm	Z _o 1/h	Z _o NB	SB	Kgm ²	IM B5 	Jm x 10 ⁻⁴ kgm ²	Z _o 1/h	Mb Nm	Mod.	Mb Nm	Z _o 1/h	Z _o 1/h	IM B5 	Jm x 10 ⁻⁴ kgm ²	Z _o 1/h	Mb max Nm	Z _o 1/h	IM B5 
0.18	BN 63A	2	2730	0.63		59.9	56.9	51.9	0.77	0.56	3.0	2.1	2.0	2.0	3.5	FD 02	1.75	3900	4800	2.6	5.2	FA 02	1.75	4800	2.6	5.0	BA 60	5	3500	4.0	5.8	IM B5			
0.25	BN 63B	2	2740	0.87		66.0	64.8	64.8	0.76	0.72	3.3	2.3	2.3	2.3	3.9	FD 02	1.75	3900	4800	3.0	5.6	FA 02	1.75	4800	3.0	5.4	BA 60	5	3600	4.3	6.2	IM B5			
0.37	BN 63C	2	2800	1.26		69.1	66.8	66.8	0.78	0.99	3.9	2.6	2.6	3.3	5.1	FD 02	3.5	3600	4500	3.9	6.8	FA 02	3.5	4500	3.9	6.6	BA 60	5	3500	5.3	7.4	IM B5			
0.37	BN 71A	2	2820	1.25		73.8	73.0	70.6	0.76	0.95	4.8	2.8	2.6	3.5	5.4	FD 03	3.5	3000	4100	4.6	8.1	FA 03	3.5	4200	4.6	7.8	BA 70	8	3500	5.5	9.3	IM B5			
0.55	BN 71B	2	2820	1.86		76.0	75.8	74.8	0.76	1.37	5.0	2.9	2.8	4.1	6.2	FD 03	5	2900	4200	5.3	8.9	FA 03	5	4200	5.3	8.6	BA 70	8	3600	6.1	10.1	IM B5			
0.75	BN 71C	2	2810	2.6		76.6	76.2	76.2	0.76	1.86	5.1	3.1	2.8	5.0	7.3	FD 03	5	1900	3300	6.1	10	FA 03	5	3600	6.1	9.7	BA 70	8	3200	7.0	11.2	IM B5			
0.75	BN 80A	2	2810	2.6	●	76.2	75.5	68.3	0.81	1.75	4.8	2.6	2.2	7.8	8.6	FD 04	5	1700	3200	9.4	12.5	FA 04	5	3200	9.4	12.4	BA 80	18	2800	10.8	13.9	IM B5			
1.1	BN 80B	2	2800	3.8	●	76.4	76.2	75.0	0.81	2.57	4.8	2.8	2.4	9.0	9.5	FD 04	10	1500	3000	10.6	13.4	FA 04	10	3000	10.6	13.3	BA 80	18	2700	12.0	14.8	IM B5			
1.5	BN 80C	2	2800	5.1	●	79.1	79.5	77.2	0.81	3.4	4.9	2.7	2.4	11.4	11.3	FD 04	15	1300	2600	13.0	15.2	FA 04	15	2600	13.0	15.1	BA 80	18	2400	14.4	16.6	IM B5			
1.5	BN 90SA	2	2870	5.0	●	82.0	81.5	78.1	0.80	3.4	5.9	2.7	2.6	12.5	12.3	FD 14	15	900	2200	14.1	16.5	FA 14	15	2200	14.1	16.4	BA 90	35	1600	19.5	19.6	IM B5			
1.85	BN 90SB	2	2880	6.1	●	82.5	82.0	75.4	0.80	4.0	6.2	2.9	2.6	16.7	14	FD 14	15	900	2200	18.3	18.2	FA 14	15	2200	18.3	18.1	BA 90	35	1700	23.7	21.3	IM B5			
2.2	BN 90L	2	2880	7.3	●	82.7	82.1	80.8	0.80	4.8	6.3	2.9	2.7	16.7	14	FD 05	26	900	2200	21	20	FA 05	26	2200	21	20.7	BA 90	35	1700	24	21.3	IM B5			
3	BN 100L	2	2860	10.0	●	81.5	81.3	77.4	0.79	6.7	5.6	2.6	2.2	31	20	FD 15	26	700	1600	35	26	FA 15	26	1600	35	27	BA 100	50	1300	43	30	IM B5			
4	BN 100LB	2	2870	13.3	●	83.1	83.0	77.8	0.80	8.7	5.8	2.7	2.5	39	23	FD 15	40	450	900	43	29	FA 15	40	1000	43	30	BA 100	50	850	51	33	IM B5			
4	BN 112M	2	2900	13.2	●	85.5	84.5	83.0	0.82	8.2	6.9	3.0	2.9	57	28	FD 06S	40	—	950	66	39	FA 06S	40	950	66	40	BA 110	75	850	73	41	IM B5			
5.5	BN 132SA	2	2890	18.2	●	84.7	84.5	81.2	0.84	11.2	5.9	2.6	2.2	101	35	FD 06	50	—	600	112	48	FA 06	50	600	112	49	BA 140	150	500	151	67	IM B5			
7.5	BN 132SB	2	2900	25	●	86.5	86.3	84.4	0.85	14.7	6.4	2.6	2.2	145	42	FD 06	50	—	550	154	55	FA 06	50	550	154	56	BA 140	150	450	195	74	IM B5			
9.2	BN 132M	2	2930	30	●	87.0	86.5	83.6	0.86	17.7	6.7	2.8	2.3	178	53	FD 56	75	—	430	189	66	FA 06	75	430	189	67	BA 140	150	400	228	85	IM B5			
11	BN 160MR	2	2920	36	●	87.6	87.0	86.0	0.88	20.6	6.9	2.9	2.5	210	65																				
15	BN 160MB	2	2930	49	●	89.6	89.4	88.0	0.86	28.1	7.1	2.6	2.3	340	84																				
18.5	BN 160L	2	2930	60	●	90.4	90.1	89.0	0.86	34	7.6	2.7	2.3	420	97																				
22	BN 180M	2	2930	72	●	89.9	89.7	89.5	0.88	40	7.8	2.6	2.4	490	109																				
30	BN 200LA	2	2930	98	●	90.7	90.1	87.6	0.89	54	7.8	2.7	2.9	770	140																				



Pn kW		n min ⁻¹	Mn Nm	IE1	η (100%) %	η (75%) %	η (50%) %	cos φ	In [400V] A	Is In	Ms Mn	Ma Mn	Jm x 10 ⁻⁴ kgm ²	IM B5 	freno c.c. / d.c. brake G.S.-bremse / frein c.c.						freno c.a. / a.c. brake W.S.-bremse / frein c.a.											
															FD			FA			BA			FD			FA			BA		
															Mod.	Mb Nm	Z _o 1/h NB SB	Jm x 10 ⁻⁴ kgm ²	IM B5 	Mod.	Mb Nm	Z _o 1/h	Jm x 10 ⁻⁴ kgm ²	IM B5 	Mod.	Mb Nm	Z _o 1/h	Jm x 10 ⁻⁴ kgm ²	IM B5 	Mod.	Mb Nm	Z _o 1/h
0.09	BN 63A	6	880	0.98	41.0	41.0	32.9	0.53	0.60	2.1	2.1	1.8	3.4	4.6	FD 02	3.5	9000	14000	4.0	6.3	FA 02	3.5	14000	4.0	6.1	BA 60	5	12000	5.4	6.9		
0.12	BN 63B	6	870	1.32	45.0	44.0	41.8	0.60	0.64	2.1	1.9	1.7	3.7	4.9	FD 02	3.5	9000	14000	4.3	6.6	FA 02	3.5	14000	4.3	6.4	BA 60	5	12000	5.7	7.2		
0.18	BN 71A	6	900	1.91	55.0	55.5	51.0	0.69	0.68	2.6	1.9	1.7	8.4	5.5	FD 03	5.0	8100	13500	9.5	8.2	FA 03	5.0	13500	9.5	7.9	BA 70	8	12300	10.4	9.4		
0.25	BN 71B	6	900	2.7	62.0	58.5	51.4	0.71	0.82	2.6	1.9	1.7	10.9	6.7	FD 03	5.0	7800	13000	12	9.4	FA 03	5.0	13000	12	9.1	BA 70	8	12000	12.9	10.6		
0.37	BN 71C	6	910	3.9	66.0	60.0	53.3	0.69	1.17	3.0	2.4	2.0	12.9	7.7	FD 53	7.5	5100	9500	14	10.4	FA 03	7.5	9500	14	10.1	BA 70	8	8900	14.9	11.6		
0.37	BN 80A	6	910	3.9	68.0	67.4	63.3	0.68	1.15	3.2	2.2	2.0	21	9.9	FD 04	10	5200	8500	23	13.8	FA 04	10	8500	23	13.7	BA 80	18	8000	24	15.2		
0.55	BN 80B	6	920	5.7	70.0	69.8	64.3	0.68	1.67	3.9	2.6	2.2	25	11.3	FD 04	15	4800	7200	27	15.2	FA 04	15	7200	27	15.1	BA 80	18	6800	28	16.6		
0.75	BN 80C	6	920	7.8	70.0	70.0	64.4	0.65	2.38	3.8	2.5	2.2	28	12.2	FD 04	15	3400	6400	30	16.1	FA 04	15	6400	30	16.0	BA 80	18	6100	31	17.5		
0.75	BN 90S	6	920	7.8	70.0	69.0	64.2	0.68	2.27	3.8	2.4	2.2	26	12.6	FD 14	15	3400	6500	28	16.8	FA 14	15	6500	28	16.7	BA 90	35	5500	33	19.9		
1.1	BN 90L	6	920	11.4	72.9	72.6	69.1	0.69	3.2	3.9	2.3	2.0	33	15	FD 05	26	2700	5000	37	21	FA 05	26	5000	37	22	BA 90	35	4600	40	22		
1.5	BN 100LA	6	940	15.2	75.2	74.2	70.3	0.72	4.0	4.1	2.1	2.0	82	22	FD 15	40	1900	4100	86	28	FA 15	40	4100	86	29	BA 100	50	3800	94	32		
1.85	BN 100LB	6	930	19.0	76.6	72.8	62.6	0.73	4.8	4.6	2.1	2.0	95	24	FD 15	40	1700	3600	99	30	FA 15	40	3600	99	31	BA 100	50	3400	107	34		
2.2	BN 112M	6	940	22	78.5	79.0	76.5	0.73	5.5	4.8	2.2	2.0	168	32	FD 06S	60	—	2100	177	42	FA 06S	60	2100	177	44	BA 110	75	2000	184	45		
3	BN 132S	6	940	30	79.7	77.0	75.1	0.76	7.1	5.1	1.9	1.8	216	36	FD 56	75	—	1400	226	49	FA 06	75	1400	226	50	BA 140	150	1200	266	68		
4	BN 132MA	6	950	40	81.4	81.5	79.5	0.77	9.2	5.5	2.0	1.8	295	45	FD 06	100	—	1200	305	58	FA 07	100	1200	318	63	BA 140	150	1050	345	77		
5.5	BN 132MB	6	945	56	83.1	80.9	79.1	0.78	12.2	6.1	2.1	1.9	383	56	FD 07	150	—	1050	406	72	FA 07	150	1050	406	74	BA 140	150	1000	433	88		
7.5	BN 160M	6	955	75	85.0	85.0	84.8	0.81	15.7	5.9	2.2	2.0	740	83	FD 08	170	—	900	815	112	FA 08	170	900	815	113							
11	BN 160L	6	960	109	86.4	86.5	85.9	0.81	22.7	6.6	2.5	2.3	970	103	FD 08	200	—	800	1045	133	FA 08	200	800	1045	133							
15	BN 180L	6	970	148	87.7	88.0	87.3	0.82	30	6.2	2.0	2.4	1550	130	FD 09	300	—	600	1750	170												
18.5	BN 200LA	6	960	184	88.6	88.0	87.3	0.81	37	5.9	2.0	2.3	1700	145	FD 09	400	—	450	1900	185												

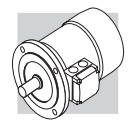

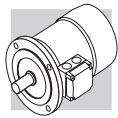











2/4 P

3000/1500 min⁻¹ - S1

50 Hz

Pn kW		n min ⁻¹	Mh Nm	η %	cos φ	In [400V] A	Is In	Ms Mn	Ma Mn	Jm x 10 ⁻⁴ kgm ²	IM B5 	freno c.c. / d.c. brake G.S.-bremse / frein c.c.						freno c.a. / a.c. brake W.S.-bremse / frein c.a.											
												FD			FA			BA			FD			FA			BA		
												Mod.	Mb Nm	Zo 1/h	Jm x 10 ⁻⁴ kgm ²	IM B5 	Mod.	Mb Nm	Zo 1/h	Jm x 10 ⁻⁴ kgm ²	IM B5 	Mod.	Mb Nm	Zo 1/h	Jm x 10 ⁻⁴ kgm ²	IM B5 			
0.20	BN 63B	2	0.71	55	0.82	0.64	3.5	2.1	1.9	2.9	4.4	FD 02	3.5	2200	2600	3.5	6.1	FA 02	3.5	2600	5100	3.5	5.9	BA 60	5	2000	4.9	6.7	
0.15		4	1.06	49	0.67	0.66	2.6	1.8	1.7	4.7	4.4		4000	5100												4000			
0.28	BN 71A	2	0.99	56	0.82	0.88	2.9	1.9	1.7	4.7	4.4	FD 03	3.5	2100	2400	5.8	7.1	FA 03	3.5	2400	4800	5.8	6.8	BA 70	8	2100	5.6	8.3	
0.20		4	1.39	59	0.72	0.68	3.1	1.8	1.7	5.8	5.1		3800	4800												4200			
0.37	BN 71B	2	1.29	56	0.82	1.16	3.5	1.8	1.8	5.8	5.1	FD 03	5	1400	2100	6.9	7.8	FA 03	5	2100	4200	6.9	7.5	BA 70	8	1800	7.8	9.0	
0.25		4	1.72	60	0.73	0.82	3.3	2.0	1.9	6.9	5.9		2900	4200												3600			
0.45	BN 71C	2	1.55	63	0.85	1.21	3.8	1.8	1.8	6.9	5.9	FD 03	5	1400	2100	8.0	8.6	FA 03	5	2100	4200	8.0	8.3	BA 70	8	1800	8.9	9.8	
0.30		4	2.0	63	0.73	0.94	3.6	2.0	1.9	15	8.2		2900	4200												3600			
0.55	BN 80A	2	1.9	63	0.85	1.48	3.9	1.7	1.7	15	8.2	FD 04	5	1600	2300	16.6	12.1	FA 04	5	2300	4000	16.6	12.0	BA 80	18	2100	18	13.5	
0.37		4	2.5	67	0.79	1.01	4.1	1.8	1.9	20	9.9		3000	4000												3700			
0.75	BN 80B	2	2.6	65	0.85	1.96	3.8	1.9	1.8	20	9.9	FD 04	10	1400	1600	22	13.8	FA 04	10	1600	3600	22	13.7	BA 80	18	1500	22	15.2	
0.55		4	3.8	68	0.81	1.44	3.9	1.7	1.7	20	9.9		2700	3600												3300			
1.1	BN 90S	2	3.8	71	0.82	2.73	4.7	2.3	2.0	21	12.2	FD 14	10	1500	1600	23	16.4	FA 14	10	1600	2800	23	16.3	BA 90	35	1300	28	19.5	
0.75		4	5.2	66	0.79	2.08	4.6	2.4	2.2	28	14.0		2300	2800												2300			
1.5	BN 90L	2	5.2	70	0.85	3.64	4.5	2.4	2.1	28	14.0	FD 05	26	1050	1200	32	20	FA 05	26	1200	2000	32	21	BA 90	35	1100	35	21	
1.1		4	7.6	73	0.81	2.69	4.7	2.5	2.2	28	14.0		1600	2000												1800			
2.2	BN 100LA	2	7.5	72	0.85	5.2	4.5	2.0	1.9	40	18.3	FD 15	26	600	900	44	25	FA 15	26	900	44	25	25	BA 100	50	750	51	29	
1.5		4	10.2	73	0.79	3.8	4.7	2.0	2.0	40	18.3		1300	2300												1900			
3.5	BN 100LB	2	11.7	80	0.84	7.5	5.4	2.2	2.1	61	25	FD 15	40	500	900	65	31	FA 15	40	900	65	32	32	BA 100	50	750	72	35	
2.5		4	16.8	82	0.80	5.5	5.2	2.2	2.2	98	30		1000	2100												1800			
4	BN 112M	2	13.3	79	0.83	8.8	6.1	2.4	2.0	98	30	FD 06S	60	—	—	107	40	FA 06S	60	700	107	42	42	BA 110	75	600	114	43	
3.3		4	22.2	80	0.80	7.4	5.1	2.1	2.0	213	44		—	—	—	—	—									1100			
5.5	BN 132S	2	18.2	80	0.87	11.4	5.9	2.4	2.0	213	44	FD 06	75	—	—	223	57	FA 06	75	350	223	58	58	BA 140	150	300	263	76	
4.4		4	29	82	0.84	9.2	5.3	2.2	2.0	270	53		—	—	—	—	—									750			
7.5	BN 132MA	2	25	82	0.87	15.2	6.5	2.4	2.0	270	53	FD 06	100	—	—	280	66	FA 07	100	350	293	71	71	BA 140	150	300	320	85	
6		4	40	84	0.85	12.1	5.8	2.3	2.1	319	59		—	—	—	—	—									800			
9.2	BN 132MB	2	30	83	0.86	18.6	6.0	2.6	2.2	319	59	FD 07	150	—	—	342	75	FA 07	150	300	342	77	77	BA 140	150	300	369	91	
7.3		4	48	85	0.85	14.6	5.5	2.3	2.1	319	59		—	—	—	—	—									750			

Pn kW		freno c.c. / d.c. brake G.S.-bremse / frein c.c.													freno c.a. / a.c. brake W.S.-bremse / frein c.a.															
		FD													FA						BA									
		Mod.	Mb Nm	Z _o 1/h	Jm x 10 ⁻⁴ kgm ²	IM B5 	Mb Nm	Z _o 1/h	Jm x 10 ⁻⁴ kgm ²	IM B5 	Mod.	Mb Nm	Z _o 1/h	Jm x 10 ⁻⁴ kgm ²	IM B5 	Mod.	Mb Nm	Z _o 1/h	Jm x 10 ⁻⁴ kgm ²	IM B5 										
0.25	BN 71A	2	2850	0.84	60	0.82	0.73	4.3	1.9	1.8	6.9	5.9	5.9	FD 03	1.75	1500	1700	8.0	8.6	FA 03	2.5	1700	8.0	8.3	BA 70	8	1500	8.9	9.8	
0.08		6	910	0.84	43	0.70	0.38	2.1	1.4	1.5					10000	13000						13000					11000			
0.37	BN 71B	2	2880	1.23	62	0.80	1.08	4.4	1.9	1.8	9.1	7.3	7.3	FD 03	3.5	1000	1300	10.2	10.0	FA 03	3.5	1300	10.2	9.7	BA 70	8	1200	11.1	11.2	
0.12		6	900	1.27	44	0.73	0.54	2.4	1.4	1.5					9000	11000						11000					10000			
0.55	BN 80A	2	2800	1.88	63	0.86	1.47	4.5	1.9	1.7	20	9.9	9.9	FD 04	5	1500	1800	22	13.8	FA 04	5	1800	22	13.7	BA 80	18	1700	23	15.2	
0.18		6	930	1.85	52	0.65	0.77	3.3	2	1.9					4100	6300						6300					6000			
0.75	BN 80B	2	2800	2.6	66	0.87	1.89	4.3	1.8	1.6	25	11.3	11.3	FD 04	5	1700	1900	27	15.2	FA 04	5	1900	27	15.1	BA 80	18	1800	28	16.6	
0.25		6	930	2.6	54	0.67	1.00	3.2	1.7	1.8					3800	6000						6000					5600			
1.1	BN 90L	2	2860	3.7	67	0.84	2.82	4.7	2.1	1.9	28	14.0	14.0	FD 05	13	1400	1600	32	20	FA 05	13	1600	32	21	BA 90	35	1500	35	21	
0.37		6	920	3.8	59	0.71	1.27	3.3	1.6	1.6					3400	5200						5200					4700			
1.5	BN 100LA	2	2880	5.0	73	0.84	3.53	5.1	1.9	2.0	40	18.3	18.3	FD 15	13	1000	1200	44	24	FA 15	13	1200	44	25	BA 100	50	1050	51	29	
0.55		6	940	5.6	64	0.67	1.85	3.5	1.7	1.8					2900	4000						4000					3500			
2.2	BN 100LB	2	2900	7.2	77	0.85	4.9	5.9	2.0	2.0	61	25	25	FD 15	26	700	900	65	31	FA 15	26	900	65	32	BA 100	50	800	72	36	
0.75		6	950	7.5	67	0.64	2.5	3.3	1.9	1.8					2100	3000						3000					2700			
3	BN 112M	2	2900	9.9	78	0.87	6.4	6.3	2.0	2.1	98	30	30	FD 06S	40	—	1000	107	40	40	FA 06S	40	1000	107	32	BA 110	75	930	114	43
1.1		6	950	11.1	72	0.64	3.4	3.9	1.8	1.8					—	2600						2600					2400			
4.5	BN 132S	2	2910	14.8	78	0.84	9.9	5.8	1.9	1.8	213	44	44	FD 56	37	—	500	223	57	57	FA 06	37	500	223	58	BA 140	150	400	263	76
1.5		6	960	14.9	74	0.67	4.4	4.2	1.9	2.0					—	2100						2100					1700			
5.5	BN 132M	2	2920	18.0	78	0.87	11.7	6.2	2.1	1.9	270	53	53	FD 56	50	—	400	280	66	66	FA 06	50	400	280	67	BA 140	150	350	320	85
2.2		6	960	22	77	0.71	5.8	4.3	2.1	2.0					—	1900						1900					1600			

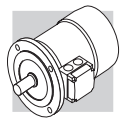

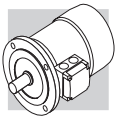





Pn kW		n min ⁻¹	Mh Nm	η %	cos φ	In [400V] A	Is In	Ms Mn	Ma Mn	Jm x 10 ⁻⁴ kgm ²	IMB5 	freno c.c. / d.c. brake G.S.-bremse / frein c.c.						freno c.a. / a.c. brake W.S.-bremse / frein c.a.											
												FD			FA			BA			FD			FA			BA		
												Mod.	Mb Nm	Zo 1/h	NB SB	IMB5 	Jm x 10 ⁻⁴ kgm ²	Mod.	Mb Nm	Zo 1/h	IMB5 	Jm x 10 ⁻⁴ kgm ²	Mod.	Mb Nm	Zo 1/h	IMB5 	Jm x 10 ⁻⁴ kgm ²		
0.25	BN 71A	2	0.86	61	0.87	0.68	3.9	1.8	1.9	10.9	6.7	FD 03	1.75	1300	1400	12	9.4	FA 03	2.5	1400	12	9.1	BA 70	8	1300	12.9	10.6		
0.06		8	0.84	31	0.61	0.46	2	1.8	1.9				10000	13000					13000						12000				
0.37	BN 71B	2	1.26	63	0.86	0.99	3.9	1.8	1.9	12.9	7.7	FD 03	3.5	1200	1300	14	10.4	FA 03	3.5	1300	14	10.1	BA 70	8	1200	14.9	11.6		
0.09		8	1.28	34	0.75	0.51	1.8	1.4	1.5				9500	13000					13000						12000				
0.55	BN 80A	2	1.86	66	0.86	1.40	4.4	2.1	2.0	20	9.9	FD 04	5	1500	1800	22	13.8	FA 04	5	1800	22	13.7	BA 80	18	1700	23	15.2		
0.13		8	1.80	41	0.64	0.72	2.3	1.6	1.7				5600	8000					8000						7500				
0.75	BN 80B	2	2.6	68	0.88	1.81	4.6	2.1	2.0	25	11.3	FD 04	10	1700	1900	27	15.2	FA 04	10	1900	27	15.1	BA 80	18	1800	28	16.6		
0.18		8	2.5	43	0.66	0.92	2.3	1.6	1.7				4800	7300					7300						7000				
1.1	BN 90L	2	3.7	63	0.84	3.00	4.5	2.1	1.9	28	14	FD 05	13	1400	1600	32	20	FA 05	13	1600	32	21	BA 90	35	1400	35	21		
0.28		8	3.9	48	0.63	1.34	2.4	1.8	1.9				3400	5100					5100						4500				
1.5	BN 100LA	2	5.0	69	0.85	3.69	4.7	1.9	1.8	40	18.3	FD 15	13	1000	1200	44	25	FA 15	13	1200	44	25	BA 100	50	1000	52	29		
0.37		8	5.1	46	0.63	1.84	2.1	1.6	1.6				3300	5000					5000						4200				
2.4	BN 100LB	2	7.9	75	0.82	5.6	5.4	2.1	2.0	61	25	FD 15	26	550	700	65	31	FA 15	26	700	65	32	BA 100	50	600	72	36		
0.55		8	7.5	54	0.58	2.5	2.6	1.8	1.8				2000	3500					3500						3100				
3	BN 112M	2	9.9	76	0.87	6.5	6.3	2.1	1.9	98	30	FD 06S	40	—	900	107	40	FA 06S	40	900	107	42	BA 110	75	800	114	43		
0.75		8	10.4	60	0.65	2.8	2.5	1.6	1.6				—	2900					2900						2700				
4	BN 132S	2	13.3	73	0.84	9.4	5.6	2.3	2.4	213	44	FD 56	37	—	500	223	57	FA 06	37	500	223	58	BA 140	150	400	263	76		
1		8	13.8	66	0.62	3.5	2.9	1.9	1.8				—	3500					3500						3000				
5.5	BN 132M	2	18.3	75	0.84	12.6	6.1	2.4	2.5	270	53	FD 06	50	—	400	280	66	FA 06	50	400	280	67	BA 140	150	350	320	85		
1.5		8	21	68	0.63	5.1	2.9	1.9	1.9				—	2400					2400						2100				

2/12 P



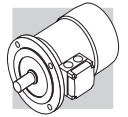

3000/500 min⁻¹ - S3 60/40%

50 Hz

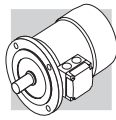



Pn kW		n min ⁻¹	Mh Nm	η %	cos φ	In [400V] A	Is In	Ms Mn	Ma Mn	Jm x 10 ⁻⁴ kgm ²	IMB5 	freno c.c. / d.c. brake G.S.-bremse / frein c.c.						freno c.a. / a.c. brake W.S.-bremse / frein c.a.											
												FD			FA			BA			FD			FA			BA		
												Mod.	Mb Nm	Zo 1/h NB SB	Jm x 10 ⁻⁴ kgm ²	IMB5 	Mod.	Mb Nm	Zo 1/h	Jm x 10 ⁻⁴ kgm ²	IMB5 	Mod.	Mb Nm	Zo 1/h	Jm x 10 ⁻⁴ kgm ²	IMB5 			
0.55	BN 80B	2 2820	1.86	64	0.89	1.39	4.2	1.6	1.7	25	11.3	FD 04	5	1000	1300	27	15.2	FA 04	5	1300	27	15.1	BA 80	18	1200	28	16.6		
0.09		12 430	2.0	30	0.63	0.69	1.8	1.9	1.8				8000	12000						12000					11000				
0.75	BN 90L	2 2790	2.6	56	0.89	2.17	4.2	1.8	1.7	26	12.6	FD 05	13	1000	1150	30	18.6	FA 05	13	1150	30	19.3	BA 90	35	1050	33	19.9		
0.12		12 430	2.7	26	0.63	1.06	1.7	1.4	1.6				4600	6300						6300					5700				
1.1	BN 100LA	2 2850	3.7	65	0.85	2.87	4.5	1.6	1.8	40	18.3	FD 15	13	700	900	44	25	FA 15	13	900	44	25	BA 100	50	750	52	29		
0.18		12 430	4.0	26	0.54	1.85	1.5	1.3	1.5				4000	6000						6000					5000				
1.5	BN 100LB	2 2900	4.9	67	0.86	3.76	5.6	1.9	1.9	54	22	FD 15	13	700	900	58	28	FA 15	13	900	58	29	BA 100	50	800	66	32		
0.25		12 440	5.4	36	0.46	2.18	1.8	1.7	1.8				3800	5000						5000					4300				
2	BN 112M	2 2900	6.6	74	0.88	4.43	6.5	2.1	2	98	30	FD 06S	20	—	800	107	40	FA 06S	20	800	107	42	BA 110	75	750	114	43		
0.3		12 460	6.2	46	0.43	2.19	2	2.1	2				—	—	3400					3400					3200				
3	BN 132S	2 2920	9.8	74	0.87	6.7	6.8	2.3	1.9	213	44	FD 56	37	—	450	223	57	FA 06	37	450	223	58	BA 140	150	380	263	76		
0.5		12 470	10.2	51	0.43	3.3	2	1.7	1.6				—	—	3000					3000					2500				
4	BN 132M	2 2920	13.1	75	0.89	8.6	5.9	2.4	2.3	270	53	FD 56	37	—	400	280	66	FA 06	37	400	280	67	BA 140	150	350	320	85		
0.7		12 460	14.5	53	0.44	4.3	1.9	1.7	1.6				—	—	2800					2800					2500				







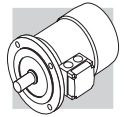

Pn kW		n min ⁻¹	Mn Nm	η %	cos φ	In [400V] A	Is In	Ms Mn	Ma Mn	Jm ⁴ x 10 ⁻⁴ kgm ²	IM B5 	freno c.c. / d.c. brake G.S.-bremse / frein c.c.						freno c.a. / a.c. brake W.S.-bremse / frein c.a.										
												FD			FA			BA			FA			BA				
												Mod.	Mb Nm	Zo 1/h	NB	SB	IM B5 	Mod.	Mb Nm	Zo 1/h	Jm ⁴ x 10 ⁻⁴ kgm ²	IM B5 	Mod.	Mb Nm	Zo 1/h	Jm ⁴ x 10 ⁻⁴ kgm ²	IM B5 	
0.22	BN 71B	4	1.5	64	0.74	0.67	3.9	1.8	1.9	9.1	7.3	FD 03	3.5	2500	3500	10.2	10	FA 03	3.5	3500	10.2	9.7	BA 70	8	3200	11.1	11.2	
0.13		6	1.4	43	0.67	0.65	2.3	1.6	1.7				5000	9000						9000				8200				
0.30	BN 80A	4	2.0	61	0.82	0.87	3.5	1.3	1.5	15	8.2	FD 04	5	2500	3100	16.6	12.1	FA 04	5	3100	16.6	12.0	BA 80	18	2800	18	13.5	
0.20		6	2.1	54	0.66	0.81	3.2	1.9	2.0				4000	6000						6000				5500				
0.40	BN 80B	4	2.7	63	0.75	1.22	3.9	1.8	1.8	20	9.9	FD 04	10	1800	2300	22	13.8	FA 04	10	2300	22	13.7	BA 80	18	2200	23	15.2	
0.26		6	2.7	55	0.70	0.97	2.7	1.5	1.6				3600	5500						5500				5200				
0.55	BN 90S	4	3.7	70	0.78	1.45	4.5	2.0	1.9	21	12.2	FD 14	10	1500	2100	23	16.1	FA 14	10	2100	23	16.3	BA 90	35	1700	28	19.5	
0.33		6	3.4	62	0.70	1.10	3.7	2.3	2.0				2500	4100						4100				3300				
0.75	BN 90L	4	5.0	74	0.78	1.88	4.3	1.9	1.8	28	14	FD 05	13	1400	2000	32	20	FA 05	13	2000	32	21	BA 90	35	1800	35	21	
0.45		6	4.7	66	0.71	1.39	3.3	2.0	1.9				2300	3600						3600				3300				
1.1	BN 100LA	4	7.2	74	0.79	2.72	5.0	1.7	1.9	82	22	FD 15	26	1400	2000	86	28	FA 15	26	2000	86	29	BA 100	50	1800	94	32	
0.8		6	8.0	65	0.69	2.57	4.1	1.9	2.1				2100	3300						3300				3000				
1.5	BN 100LB	4	9.9	75	0.79	3.65	5.1	1.7	1.9	95	25	FD 15	26	1300	1800	99	31	FA 15	26	1800	99	32	BA 100	50	1600	107	34	
1.1		6	11.1	72	0.68	3.24	4.3	2.0	2.1				2000	3000						3000				2800				
2.3	BN 112M	4	15.2	75	0.78	5.7	5.2	1.8	1.9	168	32	FD 06S	40	—	1600	177	42	FA 06S	40	1600	177	44	BA 110	75	1500	184	45	
1.5		6	14.9	73	0.72	4.1	4.9	2.0	2.0				—	2400						2400				2300				
3.1	BN 132S	4	20	83	0.83	6.5	5.9	2.1	2.0	213	44	FD 56	37	—	1200	223	57	FA 06	37	1200	223	58	BA 140	150	1000	263	76	
2		6	20	77	0.75	4.9	4.5	2.1	2.1				—	1900						1900				1600				
4.2	BN 132MA	4	27	84	0.82	8.8	5.9	2.1	2.2	270	53	FD 06	50	—	900	280	66	FA 06	50	900	280	67	BA 140	150	800	320	85	
2.6		6	26	79	0.72	6.6	4.3	2.0	2.0				—	1500						1500				1300				

4/8 P**1500/750 min⁻¹ - S1****50 Hz**

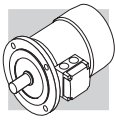



Pn kW		n min ⁻¹	Mh Nm	η %	cos φ	In [400V] A	Is In	Ms Mn	Ma Mn	Jm x 10 ⁻⁴ kgm ²	IMB5 	freno c.c. / d.c. brake G.S.-bremse / frein c.c.				freno c.a. / a.c. brake W.S.-bremse / frein c.a.							
												FD		FA		BA		FA		BA			
												Mod.	Mb Nm	Zo 1/h	Jm x 10 ⁻⁴ kgm ²	IMB5 	Mod.	Mb Nm	Zo 1/h	Jm x 10 ⁻⁴ kgm ²	IMB5 	Mod.	Mb Nm
0.37	BN 80A	4	2.5	63	0.82	1.03	3.3	1.4	1.4	15	8.2	10	2300	3500	10	10	3500	16.6	12.0	18	3200	18	13.5
0.18		8	2.5	44	0.60	0.98	2.2	1.5	1.6			10	4500	7000			7000				6500		
0.55	BN 80B	4	3.8	65	0.86	1.42	3.8	1.7	1.6	20	9.9	10	2200	2900	10	10	2900	22	13.7	23	2500	23	15.2
0.30		8	4.3	49	0.65	1.36	2.3	1.7	1.8			10	4200	6500			6500				5600		
0.65	BN 90S	4	4.5	73	0.85	1.51	4.0	1.9	1.9	28	13.6	15	2300	2800	15	15	2800	30	17.7	35	2400	35	21
0.35		8	4.8	49	0.57	1.81	2.5	2.1	2.2			15	3500	6000			6000				5100		
0.9	BN 90L	4	6.3	73	0.87	2.05	3.8	1.8	1.8	30	15.1	26	1700	2100	26	26	2100	34	22	35	1900	37	22
0.5		8	7.1	57	0.62	2.04	2.4	2.1	2			26	2500	4200			4200				3800		
1.3	BN 100LA	4	8.7	72	0.83	3.14	4.3	1.7	1.8	82	22	40	1300	1700	40	40	1700	86	29	50	1500	94	32
0.7		8	9.6	58	0.64	2.72	2.8	1.8	1.8			40	2000	3400			3400				3100		
1.8	BN 100LB	4	12.1	69	0.87	4.3	4.2	1.6	1.7	95	25	40	1200	1700	40	40	1700	99	32	50	1500	107	34
0.9		8	12.3	62	0.63	3.3	3.2	1.7	1.8			40	1600	2600			2600				2400		
2.2	BN 112M	4	14.6	77	0.85	4.9	5.3	1.8	1.8	168	32	60	—	—	60	60	1200	177	43	75	1100	184	45
1.2		8	16.1	70	0.63	3.9	3.3	1.9	1.8			60	—	—			2000				1900		
3.6	BN 132S	4	24	80	0.82	7.9	6.5	2.1	1.9	295	45	75	—	—	75	75	1000	305	59	150	900	345	77
1.8		8	24	72	0.55	6.6	4.6	1.9	2			75	—	—			1400				1200		
4.6	BN 132M	4	30	81	0.83	9.9	6.5	2.2	1.9	383	56	100	—	—	100	100	1000	406	74	150	900	433	88
2.3		8	31	73	0.54	8.4	4.4	2.3	2			100	—	—			1300				1200		









Pn kW		n min ⁻¹	Mn Nm	IE1	η (100%) %	η (75%) %	η (50%) %	cos φ	In [400V] A	Is In %	Ms Mn %	Ma Mn %	Jm x 10 ⁻⁴ kgm ²	IM B9  Kg	freno c.c. / d.c. brake G.S.-bremse / frein c.c.				freno c.a. / a.c. brake W.S.-bremse / frein c.a.						
															Mod.		Mb Nm	Zo 1/h	Jm x 10 ⁻⁴ kgm ²	IM B9  Kg	Mod.		Mb Nm	Zo 1/h	Jm x 10 ⁻⁴ kgm ²
0.18	M 05A 2	2730	0.63		59.9	56.9	51.9	0.77	0.56	3.0	2.1	2.0	2.0	3.2	FD 02	1.75	3900	4800	2.6	4.9	FA 02	1.75	4800	2.6	4.7
0.25	M 05B 2	2740	0.87		66.0	64.8	64.8	0.76	0.72	3.3	2.3	2.3	2.3	3.6	FD 02	1.75	3900	4800	3.0	5.3	FA 02	1.75	4800	3.0	5.1
0.37	M 05C 2	2800	1.26		69.1	66.8	66.8	0.78	0.99	3.9	2.6	2.6	3.3	4.8	FD 02	3.5	3600	4500	3.9	6.5	FA 02	3.5	4500	3.9	6.3
0.55	M 1SD 2	2820	1.86		76.0	75.8	74.8	0.76	1.37	5.0	2.9	2.8	4.1	5.8	FD 03	5	2900	4200	5.3	8.5	FA 03	5	4200	5.3	8.2
0.75	M 1LA 2	2810	2.6		76.6	76.2	76.2	0.76	1.86	5.1	3.1	2.8	5.0	6.9	FD 03	5	1900	3300	6.1	9.6	FA 03	5	3300	6.1	9.3
1.1	M 2SA 2	2800	3.8	●	76.4	76.2	75.0	0.81	2.57	4.8	2.8	2.4	9.0	8.8	FD 04	10	1500	3000	10.6	11.9	FA 04	10	3000	10.6	12.6
1.5	M 2SB 2	2800	5.1	●	79.1	79.5	77.2	0.81	3.4	4.9	2.7	2.4	11.4	10.6	FD 04	15	1300	2600	13.0	9.9	FA 04	15	2600	13.0	14.4
2.2	M 3SA 2	2880	7.3	●	82.7	82.1	81.0	0.80	4.8	6.3	2.9	2.7	24	15.5	FD 15	26	1100	2400	28	22	FA 15	26	2400	28	23
3	M 3LA 2	2860	10.0	●	81.5	81.3	77.4	0.79	6.7	5.6	2.6	2.2	31	18.7	FD 15	26	700	1600	35	25	FA 15	26	1600	35	26
4	M 3LB 2	2870	13.3	●	83.1	83.0	77.8	0.80	8.7	5.8	2.7	2.5	39	22	FD 15	40	450	900	43	28	FA 15	40	900	43	29
5.5	M 4SA 2	2890	18.2	●	84.7	84.5	81.2	0.84	11.2	5.9	2.6	2.2	101	33	FD 06	50	—	600	112	46	50	600	112	47	
7.5	M 4SB 2	2900	25	●	86.5	86.3	84.4	0.85	14.7	6.4	2.6	2.2	145	40	FD 06	50	—	550	154	53	50	550	154	54	
9.2	M 4LA 2	2930	30	●	87.0	86.5	83.6	0.86	17.7	6.7	2.8	2.3	178	51	FD 56	75	—	430	189	64	75	430	189	65	
11	M 4LC 2	2920	36	●	87.6	87.0	86.0	0.88	20.6	6.9	2.9	2.5	210	60											
15	M 5SB 2	2930	49	●	89.6	89.4	86.0	0.86	28.1	7.1	2.6	2.3	340	70											
18.5	M 5SC 2	2930	60	●	90.4	90.1	89.0	0.86	34	7.6	2.7	2.3	420	83											
22	M 5LA 2	2930	72	●	89.9	89.7	89.5	0.88	40	7.8	2.6	2.4	490	95											

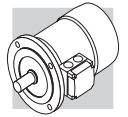

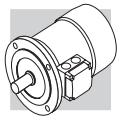

4 P**1500 min⁻¹ - S1****50 Hz**

Pn kW		n min ⁻¹	Mn Nm	IE1	η (100%) %	η (75%) %	η (50%) %	cos φ	In [400V] A	Is In -	Ms Mn -	Ma Mn -	Jm x 10 ⁻⁴ kgm ²	IM B9 	freno c.c. / d.c. brake G.S.-bremse / frein c.c.				freno c.a. / a.c. brake W.S.-bremse / frein c.a.						
															Mod	Mb Nm	Zo 1/h	NB SB	Jm x 10 ⁻⁴ Kgm ²	IM B9 	Mod.	Mb Nm	Zo 1/h	Jm x 10 ⁻⁴ kgm ²	IM B9 
0.09	M 0B 4	1350	0.64		51.7	47.6	42.9	0.60	0.42	2.6	2.5	2.4	1.5	2.9	FD 02	1.75	10000	13000	2.6	4.9	FA 02	1.75	13000	2.6	4.9
0.12	M 05A 4	1350	0.85		59.8	56.2	47.0	0.62	0.47	2.6	1.9	1.8	2.0	3.2	FD 02	3.5	10000	13000	3.0	5.3	FA 02	3.5	13000	3.0	5.1
0.18	M 05B 4	1320	1.30		54.8	52.9	52.5	0.67	0.71	2.6	2.2	2.0	2.3	3.6	FD 02	3.5	7800	10000	3.9	6.5	FA 02	3.5	10000	3.9	6.3
0.25	M 05C 4	1340	1.78		65.3	65.0	57.9	0.69	0.80	2.7	2.1	1.9	3.3	4.8	FD 03	5	6000	9400	8.0	8.2	FA 03	5	9400	8.0	7.9
0.37	M 1SD 4	1370	2.6		66.8	66.7	63.0	0.76	1.05	3.7	2.0	1.9	6.9	5.5	FD 53	7.5	4300	8700	10.2	9.6	FA 03	7.5	8700	10.2	9.3
0.55	M 1LA 4	1380	3.8		69.0	68.9	68.8	0.74	1.55	4.1	2.3	2.3	9.1	6.9	FD 04	15	4100	7800	22	13.1	FA 04	15	7800	22	13
0.75	M 2SA 4	1400	5.1	●	75.0	74.5	69.3	0.78	1.85	4.9	2.7	2.5	20	9.2	FD 04	15	2600	5300	27	14.5	FA 04	15	5300	27	14.4
1.1	M 2SB 4	1400	7.5	●	76.4	76.2	70.4	0.78	2.66	5.1	2.8	2.5	25	10.6	FD 15	26	2800	4900	38	22	FA 15	26	4900	38	23
1.5	M 3SA 4	1410	10.2	●	79.6	80.5	79.3	0.77	3.5	4.6	2.1	2.1	34	15.5	FD 15	40	2600	4700	44	24	FA 15	40	4700	44	24
2.2	M 3LA 4	1410	14.9	●	81.1	81.4	79.9	0.75	5.2	4.5	2.2	2.0	40	17	FD 15	40	2400	4400	58	27	FA 15	40	4400	58	28
3	M 3LB 4	1410	20	●	82.6	83.8	83.7	0.77	6.8	5.0	2.3	2.2	54	21	FD 55	55	—	1300	65	29	FA 15	40	1300	65	30
4	M 3LC 4	1400	27	●	82.7	83.1	80.5	0.78	9.0	4.7	2.3	2.2	61	23	FD 56	75	—	1050	223	55	FA 06	75	1050	223	56
5.5	M 4SA 4	1440	36	●	84.7	84.8	82.5	0.81	11.6	5.5	2.3	2.2	213	42	FD 06	100	—	950	280	64	FA 07	100	950	280	65
7.5	M 4LA 4	1440	50	●	86.0	86.3	85.3	0.81	15.5	5.7	2.5	2.4	270	51	FD 07	150	—	900	342	73	FA 07	150	900	342	75
9.2	M 4LB 4	1440	61	●	88.4	88.6	87.5	0.80	18.8	5.9	2.7	2.5	319	57	FD 07	150	—	850	382	81	FA 07	150	850	382	83
11	M 4LC 4	1440	73	●	87.6	87.8	86.0	0.81	22.4	6.0	2.7	2.5	360	65	FD 08	200	—	750	725	115	FA 08	200	750	710	114
15	M 5SB 4	1460	98	●	88.7	88.5	88.4	0.81	30.1	6.0	2.3	2.1	650	85	FD 08	250	—	700	865	131	FA 08	250	700	850	130
18.5	M 5LA 4	1460	121	●	89.3	89.5	89.2	0.81	37	6.2	2.6	2.5	790	101											





Pn kW		n min ⁻¹	Mn Nm	IE1	η (100%) %	η (75%) %	η (50%) %	cos φ	In [400V] A	Is In A	Ms Mn	Ma Mn	Jm x 10 ⁻⁴ kgm ²	IM B9 	freno c.c. / d.c. brake G.S.-bremse / frein c.c.				freno c.a. / a.c. brake W.S.-bremse / frein c.a.								
															FD		FA		FD		FA						
																Mod.	Mb Nm	Z ₀ 1/h	Jm x 10 ⁻⁴ kgm ²	IM B9 	Mod.	Mb Nm	Z ₀ 1/h	Jm x 10 ⁻⁴ kgm ²	IM B9 		
0.09	M 05A 6	880	0.98		41.0	41.0	32.9	0.53	0.60	2.1	2.1	1.8	3.4	4.3	FD 02	FD 02	3.5	9000	14000	4.0	FA 02	FA 02	3.5	14000	4.0	6.0	IM B9
0.12	M 05B 6	870	1.32		45.0	44.0	41.8	0.60	0.64	2.1	1.9	1.7	3.7	4.6	FD 02	FD 02	3.5	9000	14000	4.3	FA 02	FA 02	3.5	14000	4.3	6.3	IM B9
0.18	M 15C 6	900	1.91		55.0	55.5	51.0	0.69	0.68	2.6	1.9	1.7	8.4	5.1	FD 03	FD 03	5	8100	13500	9.5	FA 03	FA 03	5	13500	9.5	7.8	IM B9
0.25	M 15D 6	900	2.7		62.0	58.5	51.4	0.71	0.82	2.6	1.9	1.7	10.9	6.3	FD 03	FD 03	5	7800	13000	12	FA 03	FA 03	5	13000	12	9	IM B9
0.37	M 1LA 6	910	3.9		66.0	60.0	53.3	0.69	1.17	3.0	2.4	2.0	12.9	7.3	FD 53	FD 53	7.5	5100	9500	14	FA 03	FA 03	7.5	9500	14	10	IM B9
0.55	M 25A 6	920	5.7		70.0	69.8	64.3	0.68	1.67	3.9	2.6	2.2	25	10.6	FD 04	FD 04	15	4800	7200	27	FA 04	FA 04	15	7200	27	14.5	IM B9
0.75	M 25B 6	920	7.8	●	70.0	70.0	64.4	0.65	2.38	3.8	2.5	2.2	28	11.5	FD 04	FD 04	15	3400	6400	30	FA 04	FA 04	15	6400	30	15.4	IM B9
1.1	M 35A 6	920	11.4	●	75.0	74.0	72.0	0.72	2.9	4.3	2.0	1.8	33	17	FD 15	FD 15	26	2700	5000	37	FA 15	FA 15	26	5000	37	23	IM B9
1.5	M 3LA 6	940	15.2	●	75.2	74.2	70.3	0.72	4.0	4.1	2.1	2.0	82	21	FD 15	FD 15	40	1900	4100	86	FA 15	FA 15	40	4100	86	27	IM B9
1.85	M 3LB 6	930	19.0	●	76.6	72.8	62.6	0.73	4.8	4.6	2.1	2.0	95	23	FD 15	FD 15	40	1700	3600	99	FA 15	FA 15	40	3600	99	29	IM B9
2.2	M 3LC 6	930	23	●	77.7	76.8	72.4	0.71	5.8	4.7	2.3	2.1	95	23	FD 55	FD 55	55	—	1900	99	FA 15	FA 15	55	1900	99	29	IM B9
3	M 4SA 6	940	30	●	79.7	77.0	75.1	0.76	7.1	5.1	1.9	1.8	216	34	FD 56	FD 56	75	—	1400	226	FA 06	FA 06	75	1400	226	47	IM B9
4	M 4LA 6	950	40	●	81.4	81.5	79.5	0.77	9.2	5.5	2.0	1.8	295	43	FD 06	FD 06	100	—	1200	305	FA 07	FA 07	100	1200	305	56	IM B9
5.5	M 4LB 6	945	56	●	83.1	80.9	79.1	0.78	12.2	6.1	2.1	1.9	383	54	FD 07	FD 07	150	—	1050	406	FA 07	FA 07	150	1050	406	70	IM B9
7.5	M 5SA 6	955	75	●	85.0	85.0	84.8	0.81	15.7	5.9	2.2	2.0	740	69	FD 08	FD 08	170	—	900	815	FA 08	FA 08	170	900	800	98	IM B9
11	M 5SB 6	960	109	●	86.4	86.5	85.9	0.81	22.7	6.6	2.5	2.3	970	89	FD 08	FD 08	200	—	800	1045	FA 08	FA 08	200	800	1030	118	IM B9

Pn kW		n min ⁻¹	Mn Nm	η %	cos φ	In [400V] A	Is In	Ms Mn	Ma Mn	Jm ⁴ x 10 ⁻⁴ kgm ²	IM B9 	freno c.c. / d.c. brake G.S.-bremse / frein c.c.				freno c.a. / a.c. brake W.S.-bremse / frein c.a.						
												Mod.	Nm	Zo 1/h	NB SB	Jm ⁴ x 10 ⁻⁴ kgm ²	IM B9 	Mod.	Nm	Zo 1/h	Jm ⁴ x 10 ⁻⁴ kgm ²	IM B9 
0.20	M 05A	2	0.71	55	0.82	0.64	3.5	2.1	1.9	2.9	4.1	FD 02	3.5	2200	2600	2600	2600	FA 02	3.5	2600	3.5	5.6
0.15	M 10A	4	1.06	49	0.67	0.66	2.6	1.8	1.7	4.7	4	FD 03	3.5	4000	5100	5100	5100	FA 03	3.5	5100	5.8	6.4
0.28	M 15B	2	0.99	56	0.82	0.88	2.9	1.9	1.7	5.8	4.7	FD 03	3.5	2100	2400	2400	2400	FA 03	3.5	2400	5.8	6.4
0.20	M 15C	4	1.39	59	0.68	1.02	3.1	1.8	1.7	5.8	4.7	FD 03	3.5	3800	4800	4800	4800	FA 03	3.5	4800	5.8	6.4
0.37	M 15C	2	1.29	56	0.82	1.16	3.5	1.8	1.8	5.8	4.7	FD 03	5	1400	2100	2100	2100	FA 03	5	2100	6.9	7.1
0.25	M 15C	4	1.72	60	0.73	0.82	3.3	2	1.9	6.9	5.5	FD 03	5	2900	4200	4200	4200	FA 03	5	4200	8	7.9
0.45	M 15D	2	1.55	63	0.85	1.21	3.8	1.8	1.8	6.9	5.5	FD 03	5	1400	2100	2100	2100	FA 03	5	2100	8	7.9
0.30	M 15D	4	2.0	63	0.74	0.93	3.8	2.1	1.9	9.1	6.9	FD 03	5	2900	4200	4200	4200	FA 03	5	4200	10.2	9.3
0.55	M 15A	2	1.9	73	0.79	1.38	4.2	2	1.8	9.1	6.9	FD 03	5	1600	2200	2200	2200	FA 03	5	2200	10.2	9.3
0.37	M 15A	4	2.5	68	0.72	1.09	3.9	2.2	2	20	9.2	FD 03	5	3300	4600	4600	4600	FA 03	5	4600	10.2	9.3
0.75	M 25A	2	2.6	65	0.85	1.96	3.8	1.9	1.8	20	9.2	FD 04	10	1400	1600	1600	1600	FA 04	10	1600	22	13
0.55	M 25A	4	3.8	68	0.81	1.44	3.9	1.7	1.7	25	10.7	FD 04	10	2700	3600	3600	3600	FA 04	10	3600	22	13
1.1	M 25B	2	3.9	65	0.86	2.84	3.9	2	1.9	25	10.7	FD 04	10	1200	1500	1500	1500	FA 04	10	1500	27	14.5
0.75	M 25B	4	5.1	75	0.81	1.78	4.5	2.1	2	34	15.5	FD 15	26	2300	3100	3100	3100	FA 04	10	3100	27	14.5
1.5	M 35A	2	5.1	74	0.83	3.5	4.7	2.1	2	34	15.5	FD 15	26	700	1000	1000	1000	FA 15	26	1000	38	23
1.1	M 35A	4	7.4	77	0.78	2.6	4.3	2.1	2	40	17	FD 15	26	1600	2600	2600	2600	FA 15	26	2600	38	23
2.2	M 35A	2	7.5	72	0.85	5.2	4.5	2	1.9	40	17	FD 15	26	600	900	900	900	FA 15	26	900	44	24
1.5	M 35A	4	10.2	73	0.79	3.8	4.7	2	2	40	17	FD 15	26	1300	2300	2300	2300	FA 15	26	2300	44	24
3.5	M 35B	2	11.7	80	0.84	7.5	5.4	2.2	2.1	61	23	FD 15	40	500	900	900	900	FA 15	40	900	65	30
2.5	M 35B	4	16.8	82	0.80	5.5	5.2	2.2	2.2	61	23	FD 15	40	1000	2100	2100	2100	FA 15	40	2100	65	30
4.8	M 4 SA	2	15.8	81	0.88	9.7	6	2	1.9	213	42	FD 06	50	—	—	—	—	FA 06	50	400	233	56
3.8	M 4 SA	4	25.4	81	0.84	8.1	5.2	2.1	2.1	213	42	FD 06	50	—	—	—	—	FA 06	50	950	233	56
5.5	M 45B	2	18.2	80	0.87	11.4	5.9	2.4	2	213	42	FD 56	75	—	—	—	—	FA 06	75	350	223	56
4.4	M 45B	4	29	82	0.84	9.2	5.3	2.2	2	213	42	FD 56	75	—	—	—	—	FA 06	75	900	223	56
7.5	M 45A	2	25	82	0.87	15.2	6.5	2.4	2	270	51	FD 06	100	—	—	—	—	FA 07	100	350	280	65
6	M 45A	4	40	84	0.85	12.1	5.8	2.3	2.1	270	51	FD 06	100	—	—	—	—	FA 07	100	950	280	65
9.2	M 45B	2	30	83	0.86	18.6	6	2.6	2.2	319	57	FD 07	150	—	—	—	—	FA 07	150	300	342	75
7.3	M 45B	4	48	85	0.85	14.6	5.5	2.3	2.1	319	57	FD 07	150	—	—	—	—	FA 07	150	800	342	75

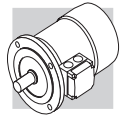

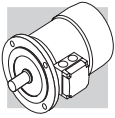









2/6 P

3000/1000 min⁻¹ - S3 60/40%



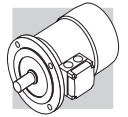

50 Hz

Pn kW		n min ⁻¹	Mn Nm	η %	cos φ	In [400V] A	$\frac{I_s}{I_n}$	$\frac{M_s}{M_n}$	$\frac{M_a}{M_n}$	$\frac{J_m}{kgm^2}$	IM B9  Kg	freno c.c. / d.c. brake G.S.-bremse / frein c.c.						freno c.a. / a.c. brake W.S.-bremse / frein c.a.					
												FD			FA								
												Mod.	Mb Nm	Z ₀ 1/h	$\frac{J_m}{kgm^2}$	IM B9  Kg	Mod.	Mb Nm	Z ₀ 1/h	$\frac{J_m}{kgm^2}$	IM B9  Kg		
0.25	M1SA	2850	0.84	60	0.82	0.73	4.3	1.9	1.8	6.9	5.5	FD 03	1.75	1500	1700	8	8.2	FA 03	1.75	1700	8	7.9	
0.08		910	0.84	43	0.70	0.38	2.1	1.4	1.5				10000	13000						13000			
0.37	M1LA	2880	1.23	62	0.80	1.08	4.4	1.9	1.8	9.1	6.9	FD 03	3.5	1000	1300	10.2	9.6	FA 03	3.5	1300	10.2	9.3	
0.12		900	1.27	44	0.73	0.54	2.4	1.4	1.5				9000	11000						11000			
0.55	M2SA	2800	1.88	63	0.86	1.47	4.5	1.9	1.7	20	9.2	FD 04	5	1500	1800	22	13.1	FA 04	5	1800	22	13	
0.18		930	1.85	52	0.65	0.77	3.3	2.0	1.9				4100	6300						6300			
0.75	M2SB	2800	2.6	66	0.87	1.89	4.3	1.8	1.6	25	10.6	FD 04	5	1700	1900	27	14.5	FA 04	5	1900	27	14.4	
0.25		930	2.6	54	0.67	1.00	3.2	1.7	1.8				3800	6000						6000			
1.1	M3SA	2870	3.7	71	0.82	2.73	4.9	1.8	1.9	34	15.5	FD 15	13	1000	1300	38	22	FA 15	13	1300	38	23	
0.37		930	3.8	63	0.70	1.21	3.1	1.5	1.8				3500	5000						5000			
1.5	M3LA	2880	5.0	73	0.84	3.53	5.1	1.9	2.0	40	17	FD 15	13	1000	1200	44	24	FA 15	13	1200	44	24	
0.55		940	5.6	64	0.67	1.85	3.5	1.7	1.8				2900	4000						4000			
2.2	M3LB	2900	7.2	77	0.85	4.9	5.9	2.0	2.0	61	23	FD 15	26	700	900	65	29	FA 15	26	900	65	30	
0.75		950	7.5	67	0.64	2.5	3.3	1.9	1.8				2100	3000						3000			
3	M4SA	2910	9.9	74	0.88	6.6	5.6	2.0	2.1	170	36	FD 56	37	—	600	182	48	FA 06	37	600	182	50	
1.1		960	10.9	73	0.68	3.2	4.5	2.2	2				—	2200					2200				
4.5	M4SB	2910	14.8	78	0.84	9.9	5.8	1.9	1.8	213	42	FD 56	37	—	500	223	55	FA 06	37	500	223	56	
1.5		960	14.9	74	0.67	4.4	4.2	1.9	2.0				—	2100					2100				
5.5	M4LA	2920	18.0	78	0.87	11.7	6.2	2.1	1.9	270	51	FD 06	50	—	400	280	64	FA 06	50	400	280	65	
2.2		960	22	77	0.71	5.8	4.3	2.1	2.0				—	1900					1900				

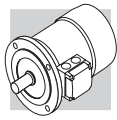
Pn kW		n min ⁻¹	Mn Nm	η %	cos φ	In [400V] A	Is In	Ms Mn	Ma Mn	Jm ⁴ kgm ²	IM B9 	freno c.c. / d.c. brake G.S.-bremse / frein c.c.						freno c.a. / a.c. brake W.S.-bremse / frein c.a.					
												Mod.	Mb Nm	Zo 1/h	NB SB	Jm ⁴ kgm ²	IM B9 	Mod.	Mb Nm	Zo 1/h	Jm ⁴ kgm ²	IM B9 	
0.37	M 1LA	2800	1.26	63	0.86	0.99	3.9	1.8	1.9	12.9	7.3	FD 03	3.5	1200	1300	14	10	FA 03	3.5	1300	14	9.7	
0.09	8	670	1.28	34	0.75	0.51	1.8	1.4	1.5	20	9.2	FD 04	5	9500	13000	22	13.1	FA 04	5	1800	22	13	
0.55	M 2SA	2830	1.86	66	0.86	1.40	4.4	2.1	2	25	10.6	FD 04	10	1500	1800	27	14.5	FA 04	10	1800	27	14.4	
0.13	8	690	1.80	41	0.64	0.72	2.3	1.6	1.7	34	15.5	FD 15	13	5600	8000	38	22	FA 15	13	5000	38	23	
0.75	M 2SB	2800	2.6	68	0.88	1.81	4.6	2.1	2	40	17	FD 15	13	1700	1900	44	24	FA 15	13	1200	44	24	
0.18	8	690	2.5	43	0.66	0.92	2.3	1.6	1.7	61	23	FD 15	26	4800	7300	50	29	FA 15	26	700	50	30	
1.1	M 3SA	2870	3.7	69	0.84	2.74	4.6	1.8	1.7	162	36	FD 56	37	1000	1300	65	48	FA 15	37	600	65	50	
0.28	8	690	3.9	44	0.56	1.64	2.3	1.4	1.7	213	42	FD 56	37	3400	5000	182	55	FA 06	37	3400	182	56	
1.5	M 3LA	2880	5.0	69	0.85	3.69	4.7	1.9	1.8	270	51	FD 06	50	1000	1200	223	64	FA 06	50	500	223	65	
0.37	8	690	5.1	46	0.63	1.84	2.1	1.6	1.6	270	51	FD 06	50	3300	5000	280	64	FA 06	50	3500	280	65	
2.4	M 3LB	2900	7.9	75	0.82	5.6	5.4	2.1	2	61	23	FD 15	26	550	700	65	29	FA 15	26	700	65	30	
0.55	8	700	7.5	54	0.58	2.5	2.6	1.8	1.8	162	36	FD 56	37	2000	3500	182	48	FA 06	37	3500	182	50	
3	M 4SA	2920	9.8	72	0.85	7.1	5.6	2	1.8	213	42	FD 56	37	—	600	600	48	FA 06	37	600	182	50	
0.75	8	710	10.1	61	0.64	2.8	3	1.7	1.8	270	51	FD 06	50	—	3400	3400	55	FA 06	50	3400	182	56	
4	M 4SB	2870	13.3	73	0.84	9.4	5.6	2.3	2.4	270	51	FD 06	50	—	500	500	64	FA 06	50	500	223	65	
1	8	690	13.8	66	0.62	3.5	2.9	1.9	1.8	270	51	FD 06	50	—	3500	3500	64	FA 06	50	3500	280	65	
5.5	M 4LA	2870	18.3	75	0.84	12.6	6.1	2.4	2.5	270	51	FD 06	50	—	400	400	64	FA 06	50	400	280	65	
1.5	8	690	21	68	0.63	5.1	2.9	1.9	1.9	270	51	FD 06	50	—	2400	2400	64	FA 06	50	2400	280	65	



2/12 P**3000/500 min⁻¹ - S3 60/40%****50 Hz**

Pn kW		n min ⁻¹	Mn Nm	η %	cos φ	In [400V] A	$\frac{I_s}{I_n}$	$\frac{M_s}{M_n}$	$\frac{M_a}{M_n}$	$\frac{J_m}{kgm^2}$	IM B9 	freno c.c. / d.c. brake G.S.-bremse / frein c.c.						freno c.a. / a.c. brake W.S.-bremse / frein c.a.					
												Mod.	Mb Nm	Z _o 1/h	NB SB	$\frac{J_m}{kgm^2}$	IM B9 	Mod.	Mb Nm	Z _o 1/h	$\frac{J_m}{kgm^2}$	IM B9 	
0.55	M 2SA	2820	1.86	64	0.89	1.39	4.2	1.6	1.7	25	10.6	FD 04	5	1000	1300	27	14.5	FA 04	5	1300	27	14.4	
0.09		430	2.0	30	0.63	0.69	1.8	1.9	1.8				8000	12000						12000			
0.75	M 3SA	2900	2.5	65	0.81	2.06	5.2	1.9	2.1	34	15.5	FD 15	13	700	900	38	22	FA 15	13	900	38	23	
0.12		460	2.5	33	0.43	1.22	1.9	1.3	1.6				5000	7000					7000				
1.1	M 3LA	2850	3.7	65	0.85	2.87	4.5	1.6	1.8	40	17	FD 15	13	700	900	44	24	FA 15	13	900	44	24	
0.18		430	4.0	26	0.54	1.85	1.5	1.3	1.5				4000	6000					6000				
1.5	M 3LB	2900	4.9	67	0.86	3.76	5.6	1.9	1.9	54	21	FD 15	13	700	900	58	27	FA 15	13	900	58	28	
0.25		440	5.4	36	0.46	2.18	1.8	1.7	1.8				3800	5000					5000				
2	M 3LC	2850	6.7	70	0.84	4.9	4.9	1.8	1.7	61	23	FD 55	18	—	700	65	29	FA 15	18	700	65	30	
0.3		450	6.4	38	0.47	2.4	1.7	1.6	1.7				—	3500					3500				
3	M 4SA	2920	9.8	74	0.87	6.7	6.8	2.3	1.9	213	42	FD 56	37	—	450	223	55	FA 06	37	450	223	56	
0.5		470	10.2	51	0.43	3.3	2	1.7	1.6				—	3000					3000				
4	M 4LA	2920	13.1	75	0.89	8.6	5.9	2.4	2.3	270	51	FD 56	37	—	400	280	64	FA 06	37	400	280	65	
0.7		460	14.5	53	0.44	4.3	1.9	1.7	1.6				—	2800					2800				

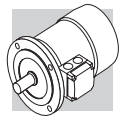

**M12 - DIMENSIONI
MOTORI**

***M12 - MOTORS
DIMENSIONS***

**M12 - MOTORENABMES-
SUNGEN**

***M12 - DIMENSIONS
MOTEURS***

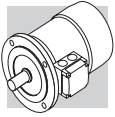

BN

IM B14

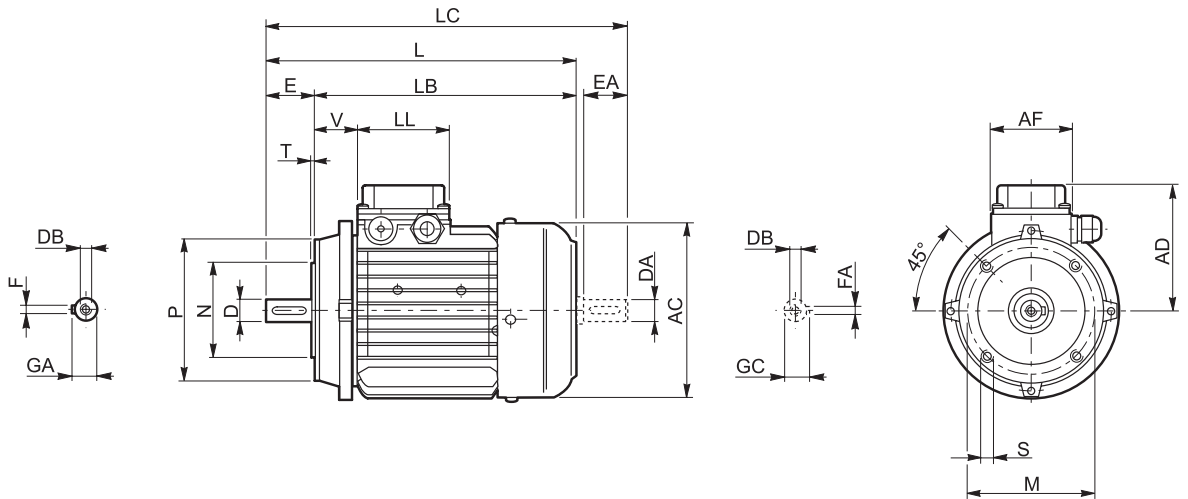

	Albero / Shaft / Welle / Arbre					Flangia / Flange / Flansch / Bride					Motore / Motor / Motor / Moteur							
	D DA	E EA	DB	GA GC	F FA	M	N	P	S	T	AC	L	LB	LC	AD	AF	LL	V
BN 56	9	20	M3	10.2	3	65	50	80	M5	2.5	110	185	165	207	91	74	80	34
BN 63	11	23	M4	12.5	4	75	60	90			121	207	184	232	95			26
BN 71	14	30	M5	16	5	85	70	105	M6		138	249	219	281	108			37
BN 80	19	40	M6	21.5	6	100	80	120		3	156	274	234	315	119	38		
BN 90	24	50	M8	27	8	115	95	140	M8		3.5	176	326	276	378	133	98	98
BN 100	28	60	M10	31		130	110	160		195		367	307	429	142	50		
BN 112						219	385	325	448	157		52						
BN 132	38	80	M12	41	10	165	130	200	M10	4	258	493	413	576	193	118	118	58

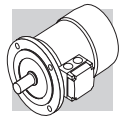

BN

IM B5

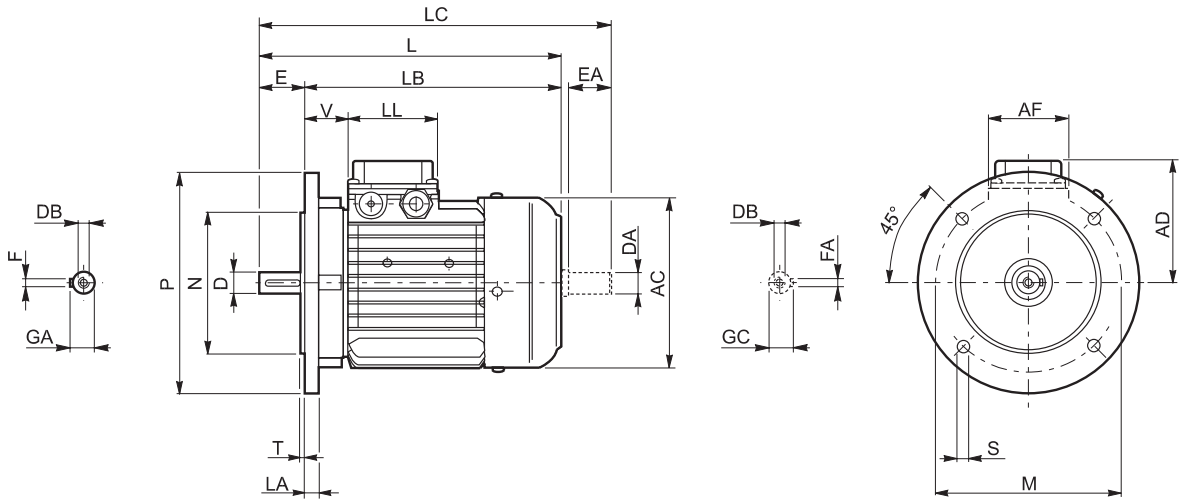

	Albero / Shaft / Welle / Arbre					Flangia / Flange / Flansch / Bride						Motore / Motor / Motor / Moteur								
	D DA	E EA	DB	GA GC	F FA	M	N	P	S	T	LA	AC	L	LB	LC	AD	AF	LL	V	
BN 56	9	20	M3	10.2	3	100	80	120	7	3	8	110	185	165	207	91	74	80	34	
BN 63	11	23	M4	12.5	4	115	95	140	9.5		10	121	207	184	232				95	26
BN 71	14	30	M5	16	5	130	110	160			10	138	249	219	281				108	37
BN 80	19	40	M6	21.5	6	165	130	200	11.5	3.5	11.5	156	274	234	315	119	98	98	38	
BN 90	24	50	M8	27	176							326	276	378	133	44				
BN 100	28	60	M10	31	8	215	180	250	14	4	14	195	367	307	429	142	98	98	50	
BN 112											15	219	385	325	448	157			52	
BN 132	38	80	M12	41	10	265	230	300	18.5	5	20	258	493	413	576	193	118	118	58	
BN 160 MR	42 38 (1)	110 80 (1)	M16 M12 (1)	45 41 (1)	12 10 (1)	300	250	350			15	310	596	486	680	245	187	187	218	
BN 160 M									18.5	640	530	724	51							
BN 160 L									5	708	598	823	52							
BN 180 M	48 38 (1)	110 110 (1)	M16 M16 (1)	51.5 41 (1)	14 10 (1)	350	300	400	18	348	722	612	837	261	187	187	66			
BN 180 L	48 42 (1)			51.5 45 (1)	14 12 (1)												52			
BN 200 L	55 42 (1)			59 45 (1)	16 12 (1)												66			

N.B.:

1) Queste dimensioni sono riferite alla seconda estremità d'albero.

NOTE:

1) These values refer to the rear shaft end.

HINWEIS:

1) Diese Maße betreffen das zweite Wellenende.

REMARQUE :

1) Ces dimensions se réfèrent à la deuxième extrémité de l'arbre.

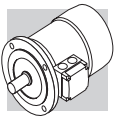

BN_FD

IM B14

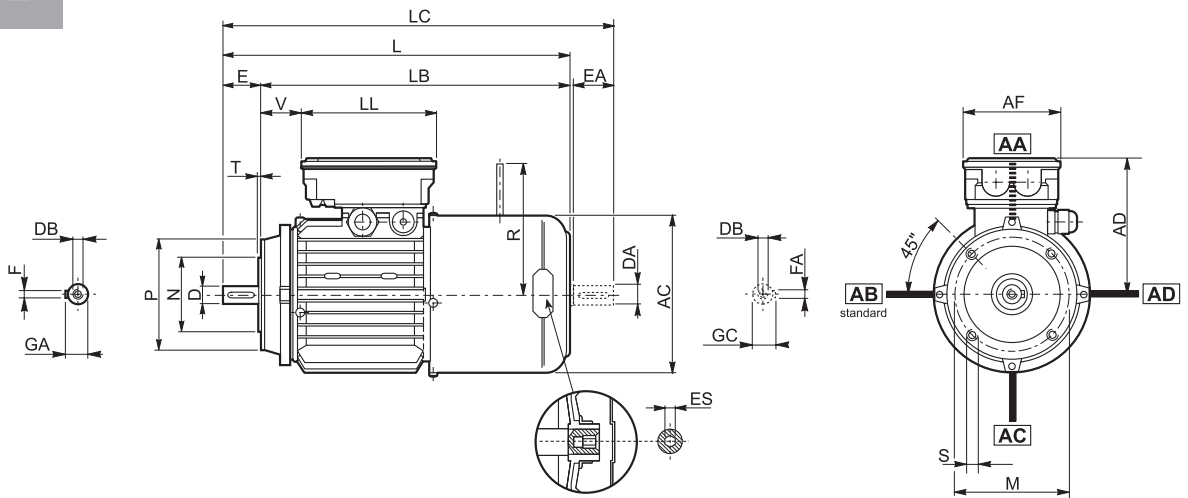

	Albero / Shaft / Welle / Arbre					Flangia / Flange / Flansch / Bride					Motore / Motor / Motor / Moteur									
	D DA	E EA	DB	GA GC	F FA	M	N	P	S	T	AC	L	LB	LC	AD	AF	LL	V	R	ES
BN 63	11	23	M4	12.5	4	75	60	90	M5	2.5	121	272	249	297	122	98	133	14	96	5
BN 71	14	30	M5	16	5	85	70	105	M6		138	310	280	342	135			25	103	
BN 80	19	40	M6	21.5	6	100	80	120	M8	3	156	346	306	388	146	110	165	41	129	6
BN 90 S	24	50	M8	27	8	115	95	140			176	409	359	461	149			39	160	
BN 90 L						130	110	160	219	484	424	547	173	62	160	73	199			
BN 100	28	60	M10	31	10	130	110	160	M10	3.5	195	458	398	521	158	140	188	62	160	6
BN 112						219	484	424			547	173	73	199						
BN 132	38	80	M12	41	10	165	130	200	M10	4	258	603	523	686	210	140	188	122	204 (1)	

N.B.:

1) Per freno FD07 quota R=226.

NOTE:

1) For FD07 brake value R=226.

HINWEIS:

1) Für Bremse FD07, Maß R=226.

REMARQUE :

1) Pour frein FD07 valeur R=226.

L'esagono ES non è presente con l'opzione PS.

ES hexagon is not supplied with PS option.

Der Sechskant ES ist bei der Option PS nicht vorhanden.

L'hexagone ES n'est pas disponible avec l'option PS.

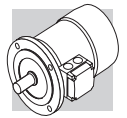

BN_FD

IM B5

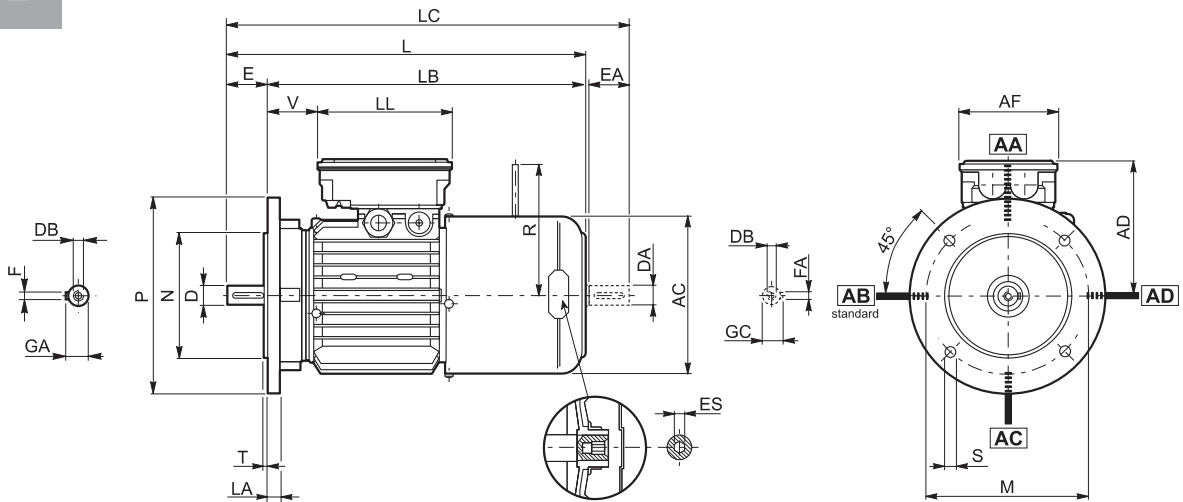

	Albero / Shaft / Welle / Arbre					Flangia / Flange / Flansch / Bride						Motore / Motor / Motor / Moteur									
	D DA	E EA	DB	GA GC	F FA	M	N	P	S	T	LA	AC	L	LB	LC	AD	AF	LL	V	R	ES
BN 63	11	23	M4	12.5	4	115	95	140	9.5	3	10	121	272	249	297	122	98	133	14	96	5
BN 71	14	30	M5	16	5	130	110	160				138	310	280	342	135			25	103	
BN 80	19	40	M6	21.5	6	165	130	200	11.5	3.5	11.5	156	346	306	388	146	110	165	41	129	6
BN 90 S	24	50	M8	27	8							176	409	359	461	149			39	160	
BN 90 L						62	199														
BN 100	28	60	M10	31	215	180	250	14	4	14	195	458	398	521	158	210	140	188	73	199	
BN 112											15	219	484	424	547				173	62	199
BN 132	38	80	M12	41	10	265	230	300	18.5	5	20	258	603	523	686	245	187	187	122	204 (2)	—
BN 160 MR	42 38 (1)	110 80 (1)	M16 M12 (1)	45 41 (1)	12 10 (1)	300	250	350				672	562	755	161				226		
BN 160 M									310	736	626	820	51	266							
BN 160 L	48 38 (1)	110 110 (1)	M16 M16 (1)	51.5 45 (1)	14 10 (1)	350	300	400	18	348	780	670	864	261	52	305					
BN 180 M											866	756	981	64							
BN 180 L	48 42 (1)	110 110 (1)	M16 M16 (1)	51.5 45 (1)	14 12 (1)	350	300	400	18	348	878	768	993	64							
BN 200 L											64										

N.B.:

1) Queste dimensioni sono riferite alla seconda estremità d'albero.

2) Per freno FD07 quota R=226.

NOTE:

1) These values refer to the rear shaft end.

2) For FD07 brake value R=226.

HINWEIS:

1) Diese Maße betreffen das zweite Wellenende.

2) Für Bremse FD07, Maß R=226.

REMARQUE :

1) Ces dimensions se réfèrent à la deuxième extrémité de l'arbre.

2) Pour frein FD07 valeur R=226.

L'esagono ES non è presente con l'opzione PS.

ES hexagon is not supplied with PS option.

Der Sechskant ES ist bei der Option PS nicht vorhanden.

L'hexagone ES n'est pas disponible avec l'option PS.

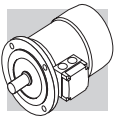

BN_FA

IM B14

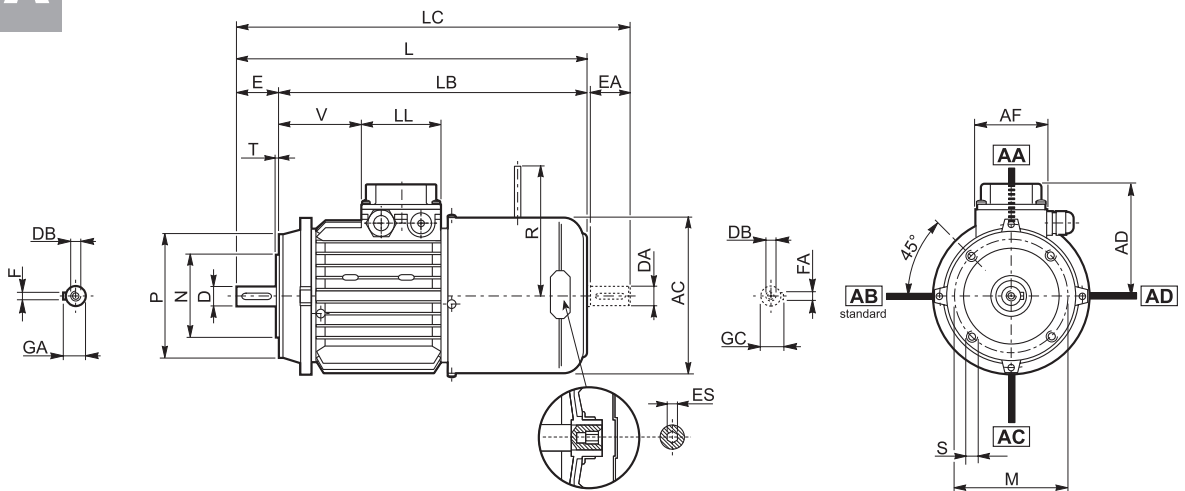

	Albero / Shaft / Welle / Arbre					Flangia / Flange / Flansch / Bride					Motore / Motor / Motor / Moteur									
	D DA	E EA	DB	GA GC	F FA	M	N	P	S	T	AC	L	LB	LC	AD	AF	LL	V	R	ES
BN 63	11	23	M4	12.5	4	75	60	90	M5	2.5	121	272	249	119	95	74	80	26	116	5
BN 71	14	30	M5	16	5	85	70	105	M6		138	310	280	342	108			68	124	
BN 80	19	40	M6	21.5	6	100	80	120		3	156	346	306	388	119			83	134	
BN 90	24	50	M8	27	8	115	95	140	M8	3.5	176	409	359	461	133	98	98	95	160	6
BN 100	28	60	M10	31		130	110	160			195	458	398	521	142			119	198	
BN 112						219	484	424	547	157	128	198								
BN 132	38	80	M12	41	10	165	130	200	M10	4	258	603	523	686	193	118	118	180	200 (1)	

N.B.:

1) Per freno FA07 quota R=217.

NOTE:

1) For FA07 brake value R=217.

HINWEIS:

1) Für Bremse FA07, Maß R=217.

REMARQUE :

1) Pour frein FA07 valeur R=217.

Per la versione BN..FA le dimensioni della scatola morsetti AD, AF, LL, V sono uguali al tipo BN..FD.

For motors type BN..FA, the terminal box sizes AD, AF, LL, V are the same as for BN..FD.

Bei der Motor typ BN..FA sind die Maße des Klemmenkastens AD, AF, LL, V denen der Version BN..FD gleich.

Pour moteurs type BN..FA les dimensions de la boîte à bornes AD, AF, LL, V sont les mêmes de BN..FD.

L'esagono ES non è presente con l'opzione PS.

ES hexagon is not supplied with PS option.

Der Sechskant ES ist bei der Option PS nicht vorhanden.

L'hexagone ES n'est pas disponible avec l'option PS.

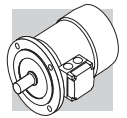

BN_FA

IM B5

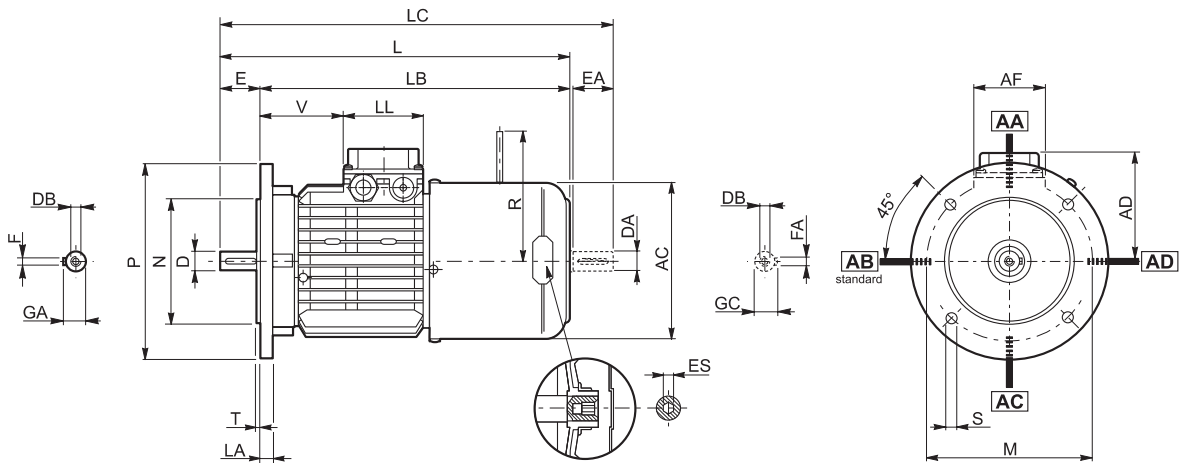

	Albero / Shaft / Welle / Arbre					Flangia / Flange / Flansch / Bride						Motore / Motor / Motor / Moteur									
	D DA	E EA	DB	GA GC	F FA	M	N	P	S	T	LA	AC	L	LB	LC	AD	AF	LL	V	R	ES
BN 63	11	23	M4	12.5	4	115	95	140	9.5	3	10	121	272	249	297	95	74	80	26	116	5
BN 71	14	30	M5	16	5	130	110	160				138	310	280	342	108			68	124	
BN 80	19	40	M6	21.5	6	165	130	200	11.5	3.5	11.5	156	346	306	388	119	98	98	83	134	6
BN 90	24	50	M8	27	176							409	359	461	133	95			160		
BN 100	28	60	M10	31	8	215	180	250	14	4	14	195	458	398	521	142	118	118	119	198	6
BN 112												15	219	484	424	547			157	128	
BN 132	38	80	M12	41	10	265	230	300	18.5	5	15	258	603	523	686	193	187	187	180	200 (2)	—
BN 160 MR	42 38 (1)	110 80 (1)	M16 M12 (1)	45 41 (1)	12 10 (1)	300	250	350				672	562	755	218	217					
BN 160 M									310	736	626	820	245	187	187	51	247				
BN 160 L	48 38 (1)	110 80 (1)	M16 M12 (1)	51.5 41 (1)	14 10 (1)	300	250	350		18.5	5	15	780	670	864	245	187	187	51	247	—

N.B.:

- 1) Queste dimensioni sono riferite alla seconda estremità d'albero.
- 2) Per freno FA07 quota R=217.

NOTE:

- 1) These values refer to the rear shaft end.
- 2) For FA07 brake value R=217.

HINWEIS:

- 1) Diese Maße betreffen das zweite Wellenende.
- 2) Für Bremse FA07, Maß R=217.

REMARQUE :

- 1) Ces dimensions se réfèrent à la deuxième extrémité de l'arbre.
- 2) Pour frein FA07 valeur R=217.

Le dimensioni AD, AF, LL e V relative alla scatola morsettieria dei motori BN...FA dotati di alimentazione separata del freno (opzione SA) coincidono con quelle dei motori BN...FD di pari taglia.

Dimensions AD, AF, LL and V, relevant to terminal box of motors BN...FA featuring the separate brake supply (option SA), are coincident with corresponding dimensions of same-size BN...FD motors.

Die Abmessungen des Klemmenkastens der Motoren BN ... FA AD, AF, LL und V in bezug auf die separate Spannungsversorgung (Option SA) stimmen mit den Abmessungen der entsprechenden Motoren BN...FD überein.

Les dimensions AD, AF, LL et V relatives à la boîte à borne des moteurs BN...FA équipés d'alimentation séparée du frein (option SA) sont identiques à celles des moteurs BN...FD de la même taille.

L'esagono ES non è presente con l'opzione PS.

ES hexagon is not supplied with PS option.

Der Sechskant ES ist bei der Option PS nicht vorhanden.

L'hexagone ES n'est pas disponible avec l'option PS.

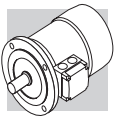

BN_BA

IM B14

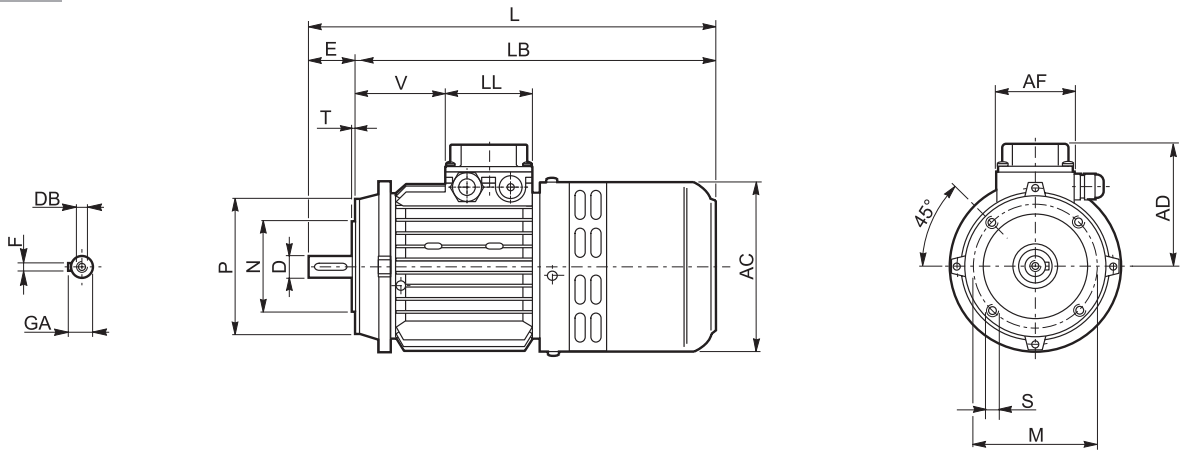

	Albero / Shaft / Welle / Arbre					Flangia / Flange / Flansch / Bride					Motore / Motor / Motor / Moteur						
	D	E	DB	GA	F	M	N	P	S	T	AC	L	LB	AD	AF	LL	V
BN 63	11	23	M4	12.5	4	75	60	90	M5	2.5	124	298	275	95	74	80	28
BN 71	14	30	M5	16	5	85	70	105	M6		138	327	297	108			68
BN 80	19	40	M6	21.5	6	100	80	120		M8	3	156	372	332	119	98	98
BN 90	24	50	M8	27	8	115	95	140	M8		3.5	176	425	375	133		
BN 100	28	60	M10	31		130	110	160		M10	4	195	477	417	142	119	
BN 112					219	500	440	157	128								
BN 132	38	80	M12	41	10	165	130	200	M10	4	258	638	558	193	118	118	180

N.B.:

Le dimensioni AD, AF, LL e V relative alla scatola morsetti dei motori BN...BA dotati di alimentazione separata del freno (opzione SA) coincidono con quelle dei motori BN...FD di pari taglia.

NOTE:

Dimensions AD, AF, LL and V, relevant to terminal box of motors BN...BA featuring the separate brake supply (option SA), are coincident with corresponding dimensions of same-size BN...FD motors

HINWEIS:

Die Abmessungen des Klemmenkastens der Motoren BN ... BA AD, AF, LL und V in bezug auf die separate Spannungsversorgung (Option SA) stimmen mit den Abmessungen der entsprechenden Motoren BN...FD überein.

REMARQUE :

Les dimensions AD, AF, LL et V relatives à la boîte à borne des moteurs BN...BA équipés d'alimentation séparée du frein (option SA) sont identiques à celles des moteurs BN...FD de la même taille.

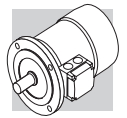

BN_BA

IM B5

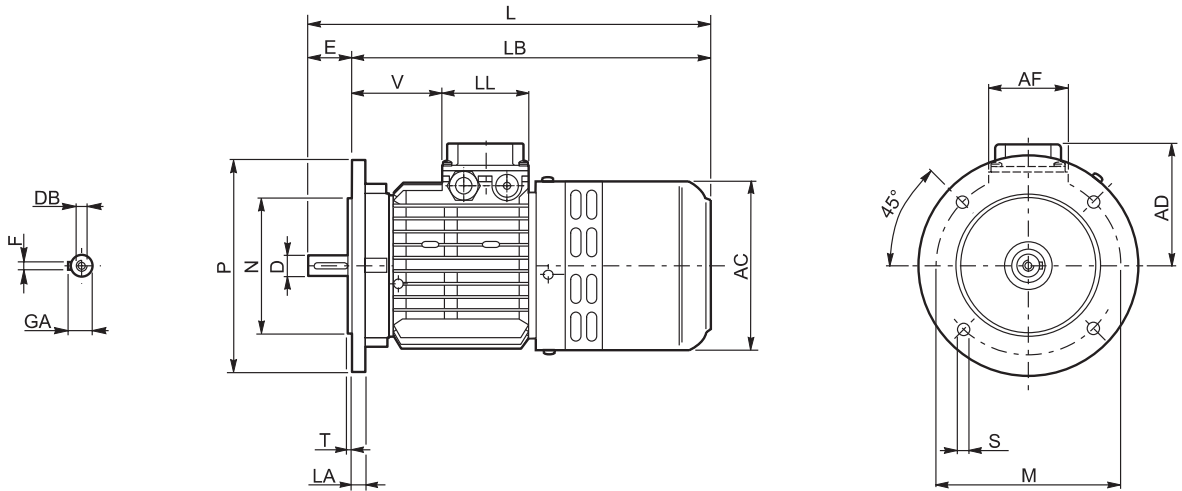

	Albero / Shaft / Welle / Arbre					Flangia / Flange / Flansch / Bride						Motore / Motor / Motor / Moteur						
	D	E	DB	GA	F	M	N	P	S	T	LA	AC	L	LB	AD	AF	LL	V
BN 63	11	23	M4	12.5	4	115	95	140	9.5	3	10	124	298	275	95	74	80	28
BN 71	14	30	M5	16	5	130	110	160		3.5		11.5	138	327	297			108
BN 80	19	40	M6	21.5	6	165	130	200	11.5	3.5	11.5	156	372	332	119	98	98	83
BN 90	24	50	M8	27	8							176	425	375	133			95
BN 100	28	60	M10	31	8	215	180	250	14	4	14	195	477	417	142	98	98	119
BN 112											15	219	500	440	157			128
BN 132	38	80	M12	41	10	265	230	300			20	258	638	558	193	118	118	180

N.B.:

Le dimensioni AD, AF, LL e V relative alla scatola morsetti dei motori BN...BA dotati di alimentazione separata del freno (opzione SA) coincidono con quelle dei motori BN...FD di pari taglia.

NOTE:

Dimensions AD, AF, LL and V, relevant to terminal box of motors BN...BA featuring the separate brake supply (option SA), are coincident with corresponding dimensions of same-size BN...FD motors

HINWEIS:

Die Abmessungen des Klemmkastens der Motoren BN ... BA AD, AF, LL und V in bezug auf die separate Spannungsversorgung (Option SA) stimmen mit den Abmessungen der entsprechenden Motoren BN...FD überein.

REMARQUE :

Les dimensions AD, AF, LL et V relatives à la boîte à borne des moteurs BN...BA équipés d'alimentation séparée du frein (option SA) sont identiques à celles des moteurs BN...FD de la même taille.

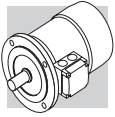

M

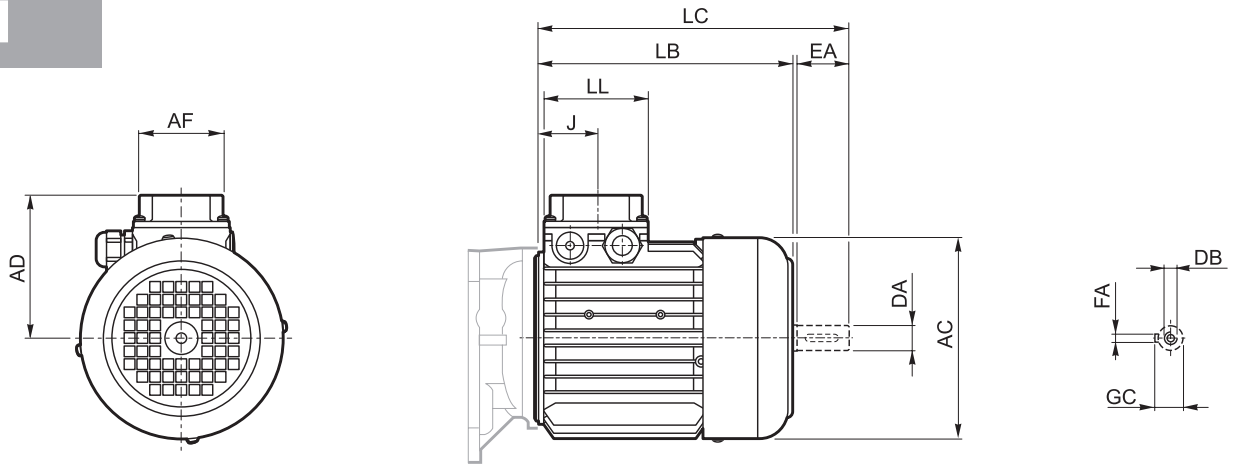

	Seconda estremità albero / Rear shaft end Zweite Wellenende / Deuxième extrémité de l'arbre					Motore / Motor / Motor / Moteur						
	DA	EA	DB	FA	GC	AC	LB	LC	AF	LL	J	AD
M 0	9	20	M3	3	10.2	110	133	155	74	80	42	91
M 05	11	23	M4	4	12.5	121	165	191			48	95
M 1	14	30	M5	5	16	138	187	219			45	108
M 2 S	19	40	M6	6	21.5	156	202	245			44	119
M 3 S	28	60	M10	8	31	195	230	293	98	98	53.5	142
M 3 L							262	325				
M 4	38	80	M12	10	41	258	361	444	118	118	64.5	193
M 4 LC							396	479				
M 5 S						310	418	502	187	187	77	245
M 5 L							462	546				

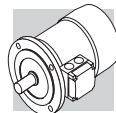

M_FD

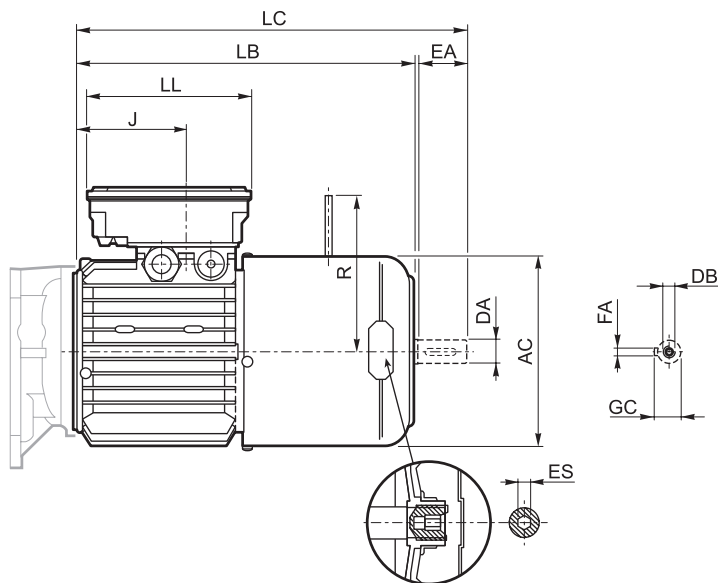
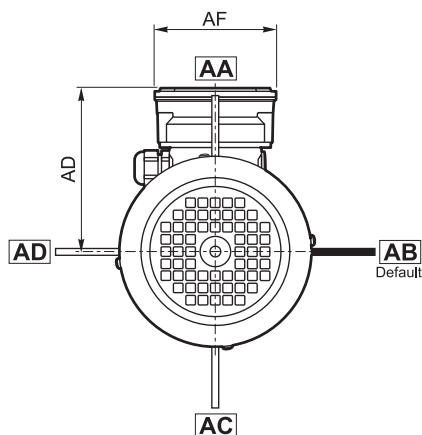

	Seconda estremità albero / Rear shaft end Zweite Wellenende / Deuxième extrémité de l'arbre					Motore / Motor / Motor / Moteur								
	DA	EA	DB	FA	GC	AC	LB	LC	AF	LL	J	AD	R	ES
M 05	11	23	M4	4	12.5	121	231	256	98	133	48	122	96	5
M 1	14	30	M5	5	16	138	248	280			73	135	103	
M 2 S	19	40	M6	6	21.5	156	272	314			88	146	129	
M 3 S	28	60	M10	8	31	195	326	389	110	165	124.5	158	160	6
M 3 L							353	416						
M 4	38	80	M12	10	41	258	470	553	140	188	185.5	210	204 (1)	
M 4 LC							495	578			64.5		226	
M 5 S						310	558	642	187	187	77	245	266	
M 5 L	602	686												

N.B.:

1) Per freno FD07 quota R=226.

NOTE:

1) For FD07 brake value R=226.

HINWEIS:

1) Für Bremse FD07, Maß R=226.

REMARQUE :

1) Pour frein FD07 valeur R=226.

L'esagono ES non è presente con l'opzione PS.

ES hexagon is not supplied with PS option.

Der Sechskant ES ist bei der Option PS nicht vorhanden.

L'hexagone ES n'est pas disponible avec l'option PS.

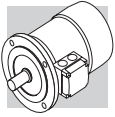

M_FA

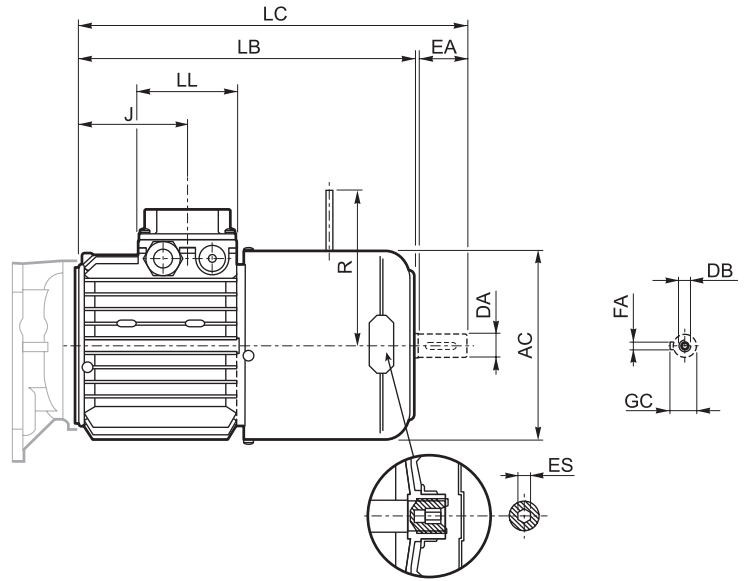
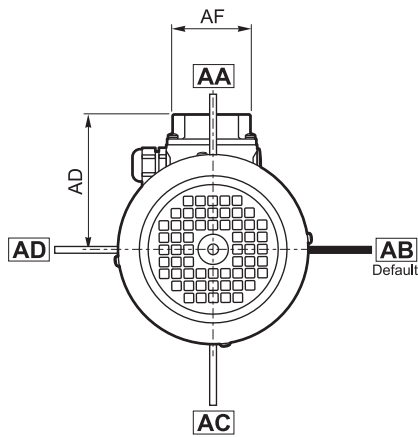

	Seconda estremità albero / Rear shaft end Zweite Wellenende / Deuxième extrémité de l'arbre					Motore / Motor / Motor / Moteur								
	DA	EA	DB	FA	GC	AC	LB	LC	AF	LL	J	AD	R	ES
M 05	11	23	M4	4	12.5	121	231	256	74	80	48	95	116	5
M 1	14	30	M5	5	16	138	248	280			73	108	124	
M 2 S	19	40	M6	6	21.5	156	272	314			88	119	134	
M 3 S	28	60	M10	8	31	195	326	389	98	98	124.5	142	160	6
M 3 L							353	416						
M 4	38	80	M14	10	41	258	470	553	118	118	185.5	193	200 (1)	
M 4 LC							495	578			64.5		217	
M 5 S			M12			310	558	642	187	187	77	245	247	—
M 5 L														

N.B.:

1) Per freno FA07 quota R=217.

NOTE:

1) For FA07 brake value R=217.

HINWEIS:

1) Für Bremse FA07, Maß R=217.

REMARQUE :

1) Pour frein FA07 valeur R=217.

L'esagono ES non è presente con l'opzione PS.

ES hexagon is not supplied with PS option.

Der Sechskant ES ist bei der Option PS nicht vorhanden.

L'hexagone ES n'est pas disponible avec l'option PS.

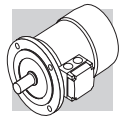

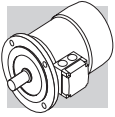

R6				
	Descrizione	Description	Beschreibung	Description
98 99	Aggiornato capitolo "Predisposizioni motori".	<i>"Motor availability" section updated.</i>	Kapitel "Baumöglichkeiten" aktualisiert.	<i>Mise à jour du chapitre «Prédispositions moteurs».</i>
161 ... 163	Aggiornato capitolo "Albero macchina".	<i>"Customer' shaft" section updated.</i>	Kapitel "Maschinachse" aktualisiert.	<i>Mise à jour du chapitre «Arbre machine».</i>
164 ... 230	Aggiornato sezione "Motori elettrici".	<i>"Electric motors" section updated.</i>	Abschnitt "Elektromotoren" aktualisiert.	<i>Mise à jour de la section «Moteurs électriques».</i>

Questa pubblicazione annulla e sostituisce ogni precedente edizione o revisione. Ci riserviamo il diritto di apportare modifiche senza preavviso. È vietata la produzione anche parziale senza autorizzazione.

This publication supersedes and replaces any previous edition and revision. We reserve the right to implement modifications without notice. This catalogue cannot be reproduced, even partially, without prior consent.

Diese Veröffentlichung annulliert und ersetzt jeder hergehende Edition oder Revision. BONFIGLIOLI behält sich das Recht vor, Änderungen ohne vorherige Informationen durchzuführen.

Cette publication annule et remplace toutes les autres précédentes. Nous nous réservons le droit d'apporter toutes modifications à nos produits. La reproduction et la publication partielle ou totale de ce catalogue est interdite sans notre autorisation.



Dal 1956 Bonfiglioli progetta e realizza soluzioni innovative ed affidabili per il controllo e la trasmissione di potenza nell'industria e nelle macchine operatrici semoventi e per le energie rinnovabili.

Bonfiglioli has been designing and developing innovative and reliable power transmission and control solutions for industry, mobile machinery and renewable energy applications since 1956.

Seit 1956 plant und realisiert Bonfiglioli innovative und zuverlässige Lösungen für die Leistungsüberwachung und -übertragung in industrieller Umgebung und für selbstfahrende Maschinen sowie Anlagen im Rahmen der erneuerbaren Energien.

Depuis 1956, Bonfiglioli conçoit et réalise des solutions innovantes et fiables pour le contrôle et la transmission de puissance dans l'industrie et dans les machines automotrices et pour les énergies renouvelables.